

NPN Silicon Epitaxial Planar Transistor

MMBT1616

FEATURES

- Audio frequency power amplifier.
- Medium speed switching.



APPLICATIONS

- General purpose application, switching application.

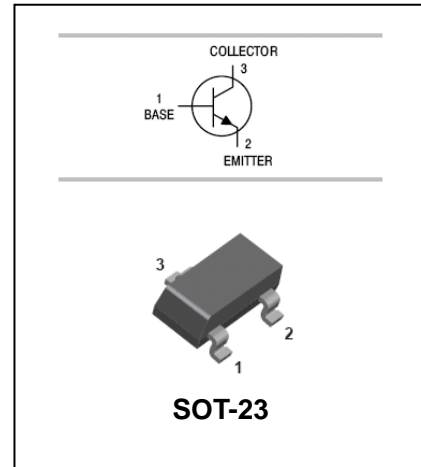

ORDERING INFORMATION

Type No.	Marking	Package Code
MMBT1616	16	SOT-23

MAXIMUM RATING @ Ta=25°C unless otherwise specified

Symbol	Parameter	Value	Units
V_{CBO}	Collector-Base Voltage	60	V
V_{CEO}	Collector-Emitter Voltage	50	V
V_{EBO}	Emitter-Base Voltage	6	V
I_C	Collector Current –Continuous DC Pulse width ≤10ms	1 2	A
P_C	Collector Power Dissipation	350	mW
T_j, T_{stg}	Junction and Storage Temperature	-55~150	°C

NPN Silicon Epitaxial Planar Transistor

MMBT1616

ELECTRICAL CHARACTERISTICS @ Ta=25°C unless otherwise specified

Parameter	Symbol	Test conditions	MIN	TYP	MAX	UNIT
Collector-base breakdown voltage	$V_{(BR)CBO}$	$I_C=100\mu A, I_E=0$	60			V
Collector-emitter breakdown voltage	$V_{(BR)CEO}$	$I_C=1mA, I_B=0$	50			V
Emitter-base breakdown voltage	$V_{(BR)EBO}$	$I_E=100\mu A, I_C=0$	6			V
Collector cut-off current	I_{CBO}	$V_{CB}=60V, I_E=0$			0.1	μA
Emitter cut-off current	I_{EBO}	$V_{EB}=6V, I_C=0$			0.1	μA
DC current gain	h_{FE}	$V_{CE}=2V, I_C=100mA$	135		600	
		$V_{CE}=2V, I_C=1A$	81			
Collector-emitter saturation voltage	$V_{CE(sat)}$	$I_C=1A, I_B=50mA$		0.15	0.3	V
Base-emitter saturation voltage	$V_{BE(sat)}$	$I_C=1A, I_B=50mA$		0.9	1.2	V
Base-emitter on voltage	$V_{BE(on)}$	$V_{CE}=2V, I_C=50mA$	0.6	0.64	0.7	V
Transition frequency	f_T	$V_{CE}=2V, I_C=100mA$	100	160		MHz
Collector output capacitance	C_{ob}	$V_{CB}=10V, I_E=0, f=1MHz$			19	pF
Turn on time	t_{on}	$V_{CE}=10V, I_C=100mA$		0.07		μS
Fall time	t_f	$V_{BE(off)}=2-3V$		0.07		μS
Storage time	t_s	$I_{B1}=I_{B2}=10mA$		0.95		μS

CLASSIFICATION OF h_{FE1}

RANK	Y	G	L
h_{FE1}	135-270	200-400	300-600

TYPICAL CHARACTERISTICS @ Ta=25°C unless otherwise specified

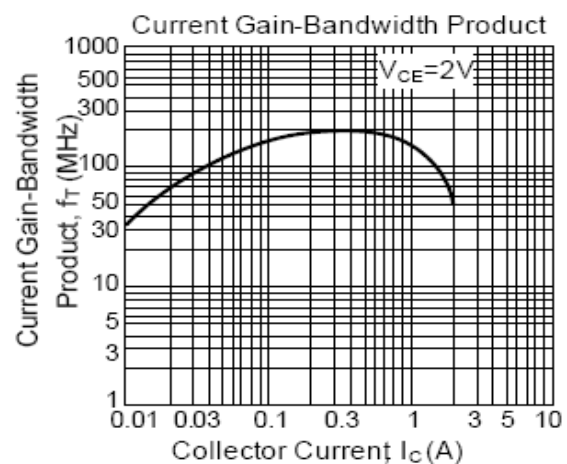
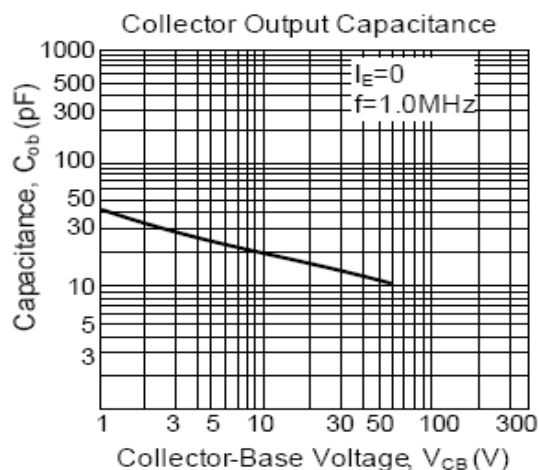

NPN Silicon Epitaxial Planar Transistor

MMBT1616

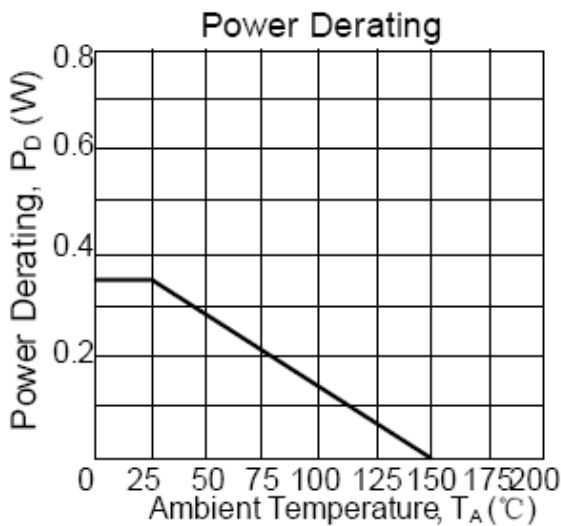
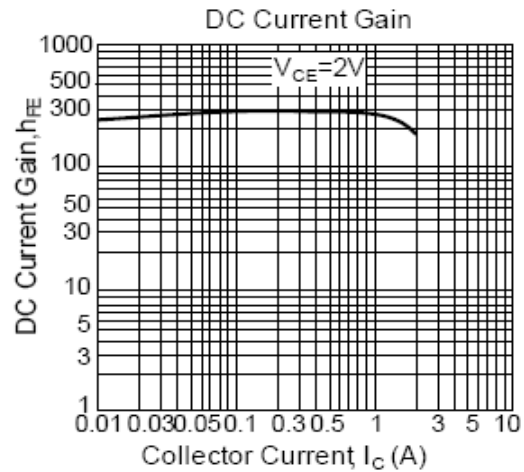
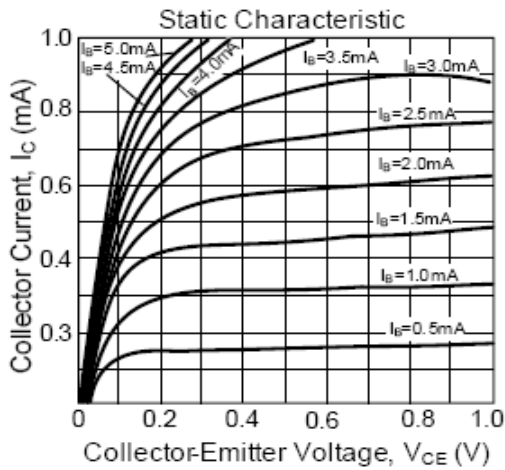
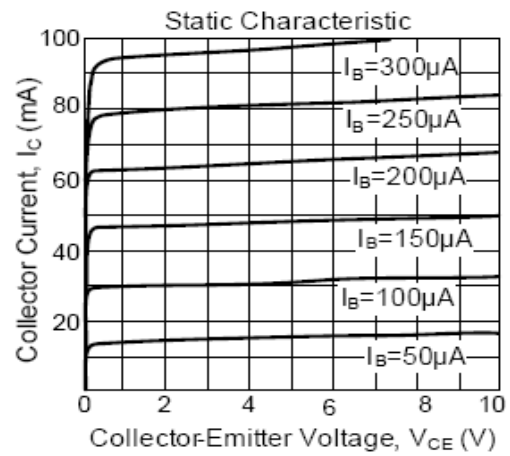
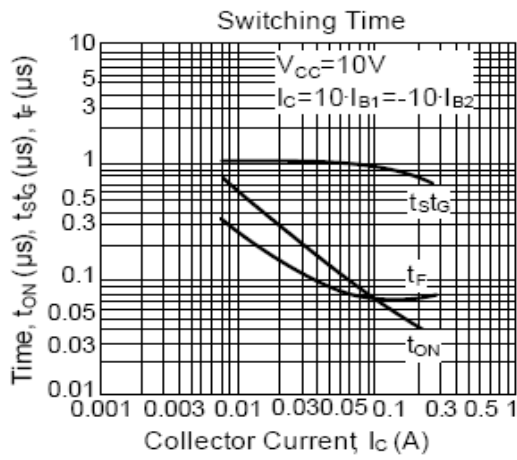

NPN Silicon Epitaxial Planar Transistor

MMBT1616

PACKAGE OUTLINE

Plastic surface mounted package

SOT-23

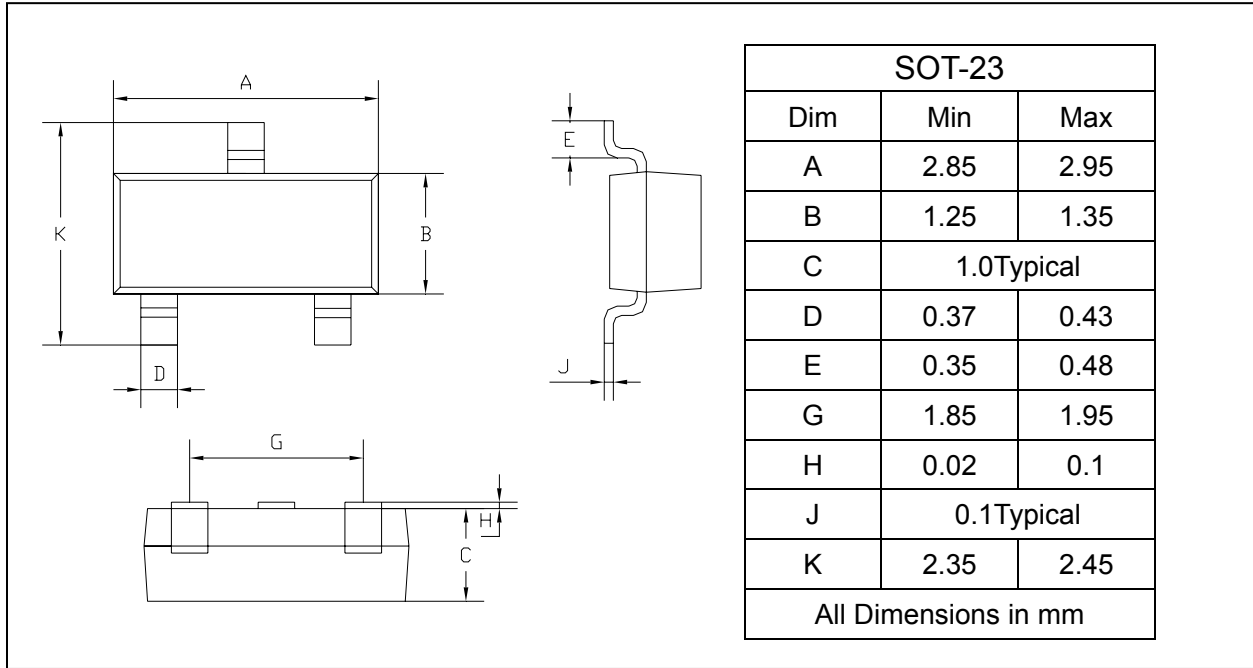

SOLDERING FOOTPRINT

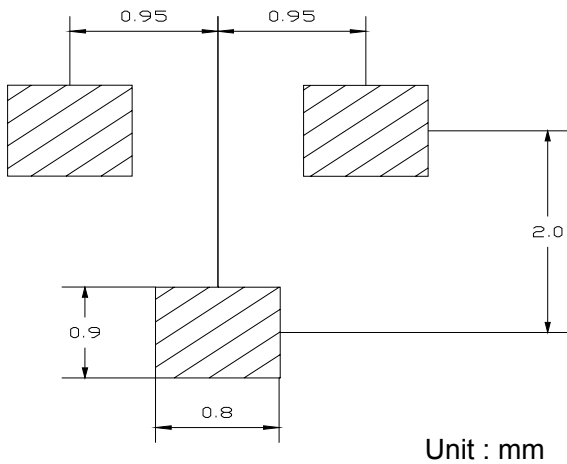

PACKAGE INFORMATION

Device	Package	Shipping
MMBT1616	SOT-23	3000/Tape&Reel