



CHENMKO ENTERPRISE CO.,LTD

Halogens free devices

SURFACE MOUNT
N-Channel Enhancement Mode Field Effect Transistor
 VOLTAGE 60 Volts CURRENT 5 Ampere

CHM3458QGP

APPLICATION

- * Servo motor control.
- * Power MOSFET gate drivers.
- * Other switching applications.

FEATURE

- * Small flat package. (SC-74/SOT-457)
- * High density cell design for extremely low $R_{DS(on)}$.
- * Rugged and reliable.
- * High saturation current capability.

CONSTRUCTION

- * N-Channel Enhancement

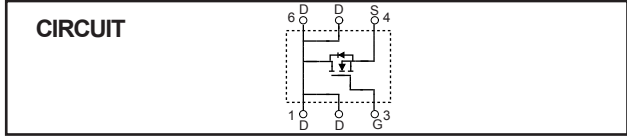
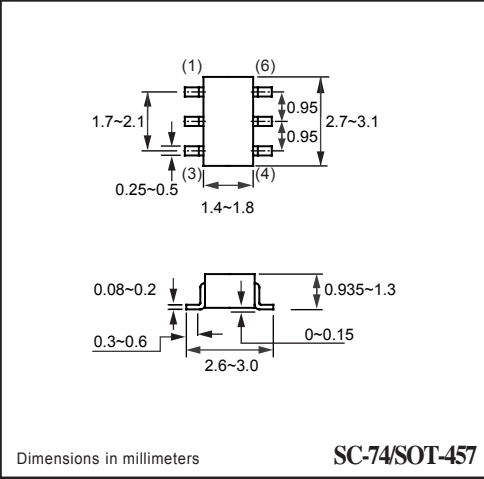
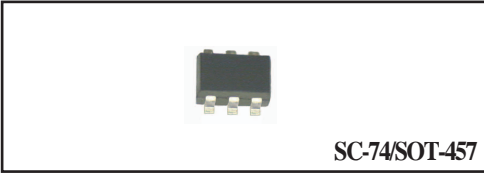

Absolute Maximum Ratings $T_A = 25^\circ\text{C}$ unless otherwise noted

Symbol	Parameter	CHM3458QGP	Units
V_{DSS}	Drain-Source Voltage	60	V
V_{GSS}	Gate-Source Voltage	± 20	V
I_D	Maximum Drain Current - Continuous	5.0	A
	- Pulsed (Note 3)	10	
P_D	Maximum Power Dissipation	2000	mW
T_J	Operating Temperature Range	-55 to 150	$^\circ\text{C}$
T_{STG}	Storage Temperature Range	-55 to 150	$^\circ\text{C}$

Note : 1. Surface Mounted on FR4 Board , $t \leq 5\text{sec}$
 2. Pulse Test , Pulse width $\leq 300\mu\text{s}$, Duty Cycle $\leq 2\%$
 3. Repetitive Rating , Pulse width limited by maximum junction temperature
 4. Guaranteed by design , not subject to production trsting

Thermal characteristics

$R_{\theta JA}$	Thermal Resistance, Junction-to-Ambient (Note 1)	90	$^\circ\text{C/W}$
-----------------	--	----	--------------------

RATING CHARACTERISTIC CURVES (CHM3458QGP)

Electrical Characteristics $T_A = 25^\circ\text{C}$ unless otherwise noted

Symbol	Parameter	Conditions	Min	Typ	Max	Units
--------	-----------	------------	-----	-----	-----	-------

OFF CHARACTERISTICS

BV_{DSS}	Drain-Source Breakdown Voltage	$V_{GS} = 0\text{ V}, I_D = 250\ \mu\text{A}$	60			V
I_{DSS}	Zero Gate Voltage Drain Current	$V_{DS} = 60\text{ V}, V_{GS} = 0\text{ V}$			1	μA
I_{GSSF}	Gate-Body Leakage	$V_{GS} = 20\text{ V}, V_{DS} = 0\text{ V}$			+100	nA
I_{GSSR}	Gate-Body Leakage	$V_{GS} = -20\text{ V}, V_{DS} = 0\text{ V}$			-100	nA

ON CHARACTERISTICS (Note 2)

$V_{GS(th)}$	Gate Threshold Voltage	$V_{DS} = V_{GS}, I_D = 250\ \mu\text{A}$	0.5		1.5	V
$R_{DS(on)}$	Static Drain-Source On-Resistance	$V_{GS}=10\text{V}, I_D=5.0\text{A}$		106	115	m Ω
		$V_{GS}=4.5\text{V}, I_D=4.5\text{A}$		118	125	
g_{FS}	Forward Transconductance	$V_{DS} = 15\text{V}, I_D = 4.0\text{A}$		12		S

SWITCHING CHARACTERISTICS (Note 4)

Q_g	Total Gate Charge	$V_{DS}=30\text{V}, I_D=4.0\text{A}$ $V_{GS}=4.5\text{V}$		4	6	nC
Q_{gs}	Gate-Source Charge			1.2		
Q_{gd}	Gate-Drain Charge			1		
t_{on}	Turn-On Time	$V_{DD}= 30\text{V}$ $I_D = 2.5\text{A}, V_{GS} = 10\text{ V}$ $R_{GEN}= 6\ \Omega$		6	10	nS
t_r	Rise Time			12	20	
t_{off}	Turn-Off Time			18	30	
t_f	Fall Time			10	15	

DRAIN-SOURCE DIODE CHARACTERISTICS AND MAXIMUM RATINGS

I_S	Drain-Source Diode Forward Current	(Note 1)			2.5	A
V_{SD}	Drain-Source Diode Forward Voltage	$I_S = 2.5\text{A}, V_{GS} = 0\text{ V}$ (Note 2)			1.2	V

RATING CHARACTERISTIC CURVES (CHM3458QGP)

Typical Electrical Characteristics

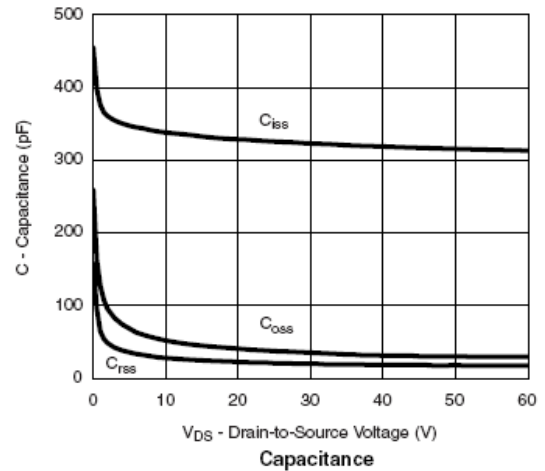
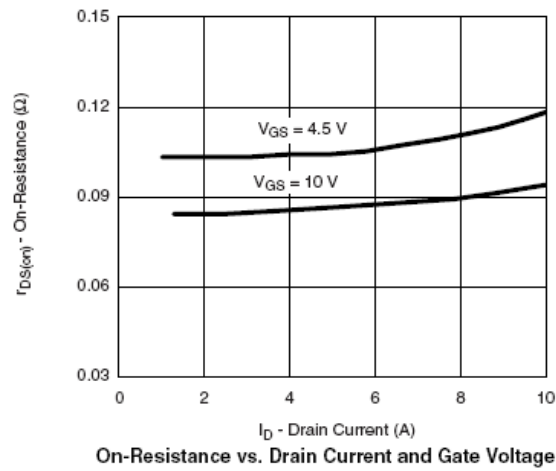
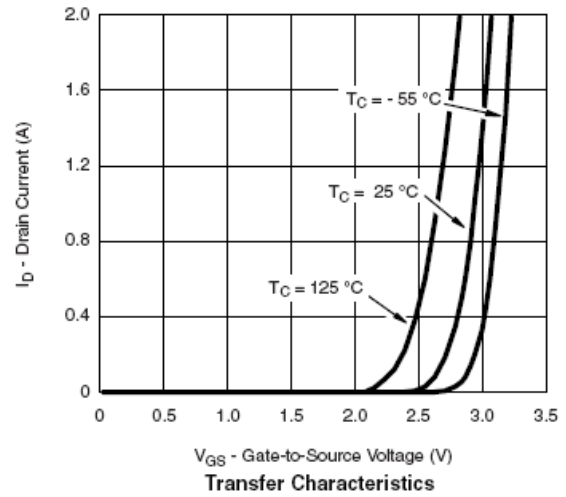
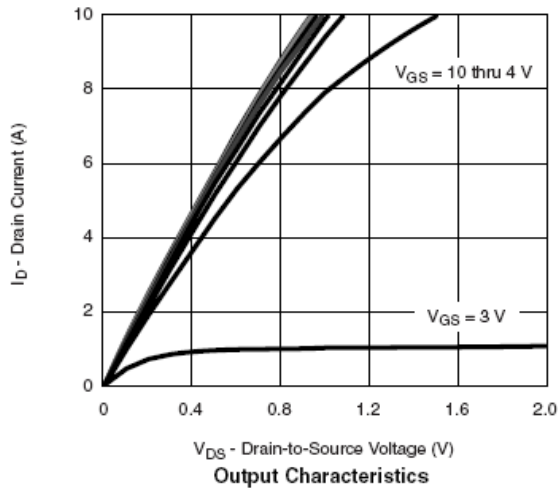

RATING CHARACTERISTIC CURVES (CHM3458QGP)

Typical Electrical Characteristics

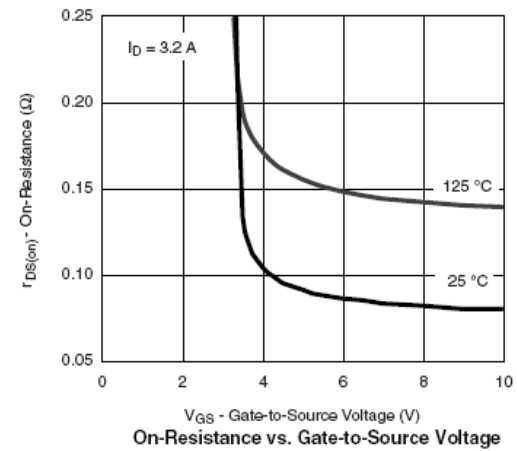
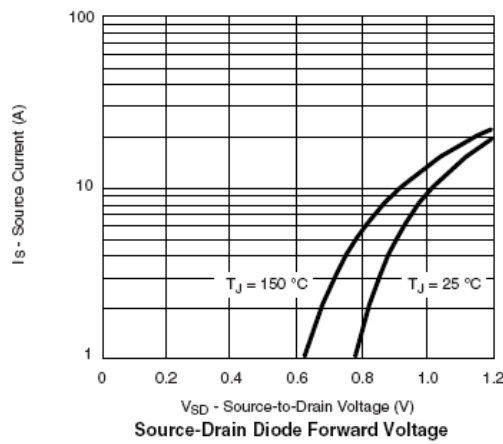
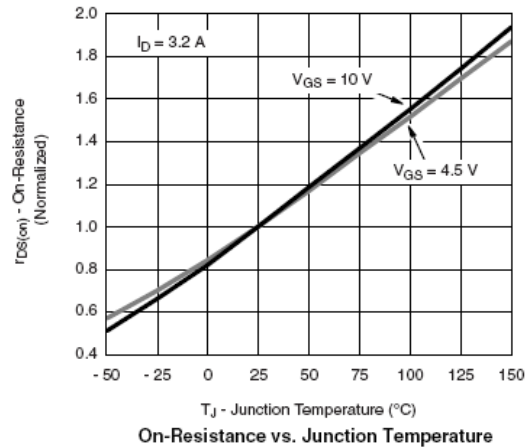
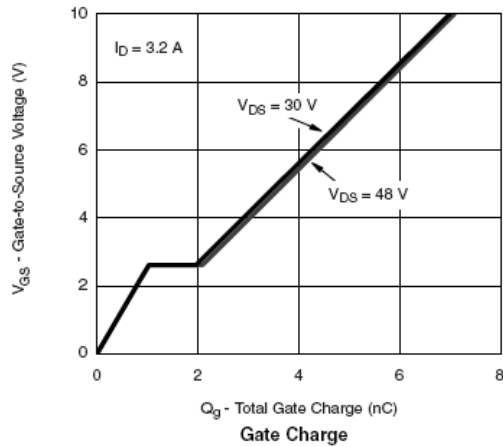

RATING CHARACTERISTIC CURVES (CHM3458QGP)

Typical Electrical Characteristics

