



**CHENMKO ENTERPRISE CO.,LTD**

*Halogens free devices*

**SURFACE MOUNT  
Dual Digital Silicon Transistor**

VOLTAGE 50 Volts CURRENT 100 mAmpere

**CHUMD6GP**

**APPLICATION**  
\* Switching circuit, Inverter, Interface circuit, Driver circuit.

**FEATURE**  
\* Small surface mounting type. (SC-88/SOT-363)  
\* High current gain.  
\* Suitable for high packing density.  
\* Low collector-emitter saturation.  
\* High saturation current capability.  
\* Both the CHDTA143T & CHDTC143T in one package.  
\* Built in bias resistor(R1=4.7kΩ, Typ. )

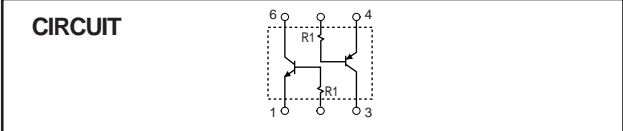
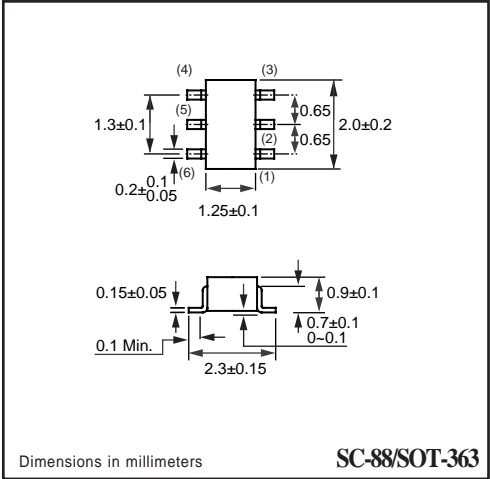
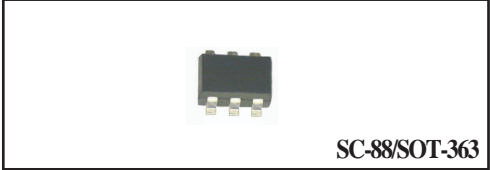

**LIMITING VALUES**  
In accordance with the Absolute Maximum Rating System (IEC 60134).

SYMBOL	PARAMETER	CONDITIONS	VALUE	UNIT
V <sub>CBO</sub>	Collector-Base voltage		50	V
V <sub>CEO</sub>	Collector-Emitter voltage		50	V
V <sub>EBO</sub>	Emitter-Base voltage		5	V
I <sub>C(Max.)</sub>	Collector current		100	mA
P <sub>D</sub>	Power dissipation	T <sub>amb</sub> ≤ 25 °C, Note 1	150	mW
T <sub>STG</sub>	Storage temperature		-55 +150	°C
T <sub>J</sub>	Junction temperature		-55 +150	°C
R <sub>θJ-S</sub>	Thermal resistance , Note 1	junction - soldering point	140	°C/W

**Note**  
1. Transistor mounted on an FR4 printed-circuit board.

## RATING CHARACTERISTIC ( CHUMD6GP )

### CHARACTERISTICS

$T_{amb} = 25\text{ }^{\circ}\text{C}$  unless otherwise specified.

SYMBOL	PARAMETER	CONDITIONS	MIN.	TYP.	MAX.	UNIT
BV <sub>CB0</sub>	Collector-base breakdown voltage	I <sub>C</sub> =50μA	50	–	–	V
BV <sub>CEO</sub>	Collector-emitter breakdown voltage	I <sub>C</sub> =1.0mA	50	–	–	V
BV <sub>EB0</sub>	Emitter-base breakdown voltage	I <sub>E</sub> =50μA	5.0	–	–	V
I <sub>CB0</sub>	Collector cutoff current	V <sub>CB</sub> =50V	–	–	0.5	μA
I <sub>EB0</sub>	Emitter cutoff current	V <sub>EB</sub> =4V	–	–	0.5	μA
V <sub>CE(sat)</sub>	Collector-emitter saturation voltage	I <sub>C</sub> /I <sub>B</sub> =5mA/0.25mA	–	–	0.3	V
h <sub>FE</sub>	DC current gain	I <sub>C</sub> =1mA; V <sub>CE</sub> =5.0V	100	250	600	
R <sub>1</sub>	Input resistor		3.29	4.7	6.11	KΩ
f <sub>T</sub>	Transition frequency	I <sub>C</sub> =5mA, V <sub>CE</sub> =10.0V f=100MHz	–	250	–	MHz

### Note

1. Pulse test: t<sub>p</sub>≤300μS; δ≤0.02.

## RATING CHARACTERISTIC CURVES ( CHUMD6GP )

### CHDTA143T Typical Electrical Characteristics

Fig.1 DC current gain vs. collector current

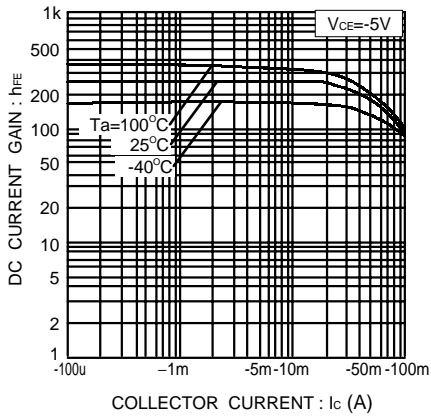
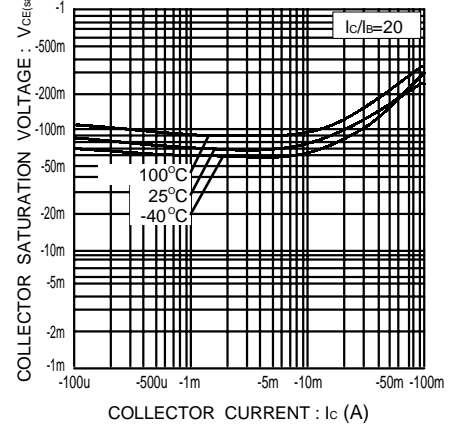

Fig.2 Collector-emitter saturation voltage vs. collector current



### CHDTC143T Typical Electrical Characteristics

Fig.1 DC current gain vs. collector current

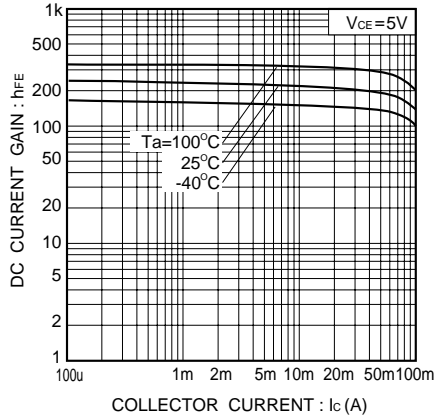

Fig.2 Collector-emitter voltage vs. collector current

