



CHENMKO ENTERPRISE CO.,LTD

Halogens free devices

SURFACE MOUNT

Dual Digital Silicon Transistor

VOLTAGE 50 Volts CURRENT 100 mAmpere



APPLICATION
 * Switching circuit, Inverter, Interface circuit, Driver circuit.

FEATURE
 * Small surface mounting type. (SC-88A/SOT-353)
 * High current gain.
 * Suitable for high packing density.
 * Low collector-emitter saturation.
 * High saturation current capability.
 * Low CHDTA124E chips in a package.
 * Built in bias resistor(R1=22kΩ, Typ.)

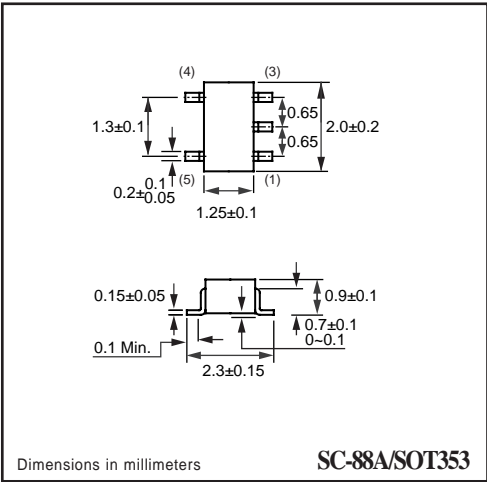
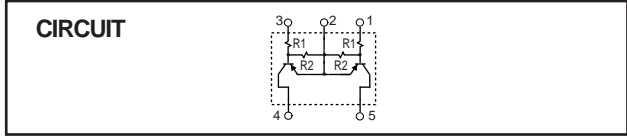
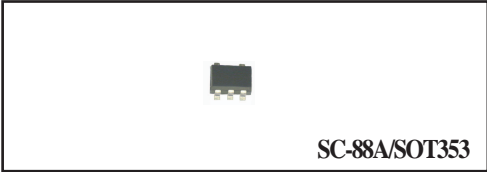

LIMITING VALUES
 In accordance with the Absolute Maximum Rating System (IEC 60134).

SYMBOL	PARAMETER	CONDITIONS	MIN.	MAX.	UNIT
V _{CC}	Supply voltage		-	-50	V
V _{IN}	Input voltage		-40	+10	V
I _O	DC Output current		-	-100	mA
P _{TOT}	Total power dissipation	T _{amb} ≤ 25 °C, Note 1	-	150	mW
T _{STG}	Storage temperature		-55	+150	°C
T _J	Junction temperature		-	150	°C

Note
 1. Transistor mounted on an FR4 printed-circuit board.

RATING CHARACTERISTIC (CHUMA1GP)

CHARACTERISTICS

$T_{amb} = 25\text{ }^{\circ}\text{C}$ unless otherwise specified.

SYMBOL	PARAMETER	CONDITIONS	MIN.	TYP.	MAX.	UNIT
$V_{I(off)}$	Input off voltage	$I_o = -100\mu\text{A}; V_{CC} = -5.0\text{V}$	-0.5	-	-	V
$V_{I(on)}$	Input on voltage	$I_o = -5\text{mA}; V_o = -0.2\text{V}$	-	-	-3.0	V
$V_{O(on)}$	Output voltage	$I_o = -10\text{mA}; I_i = -0.5\text{mA}$	-	-0.1	-0.3	V
I_i	Input current	$V_i = -5\text{V}$	-	-	-0.36	mA
$I_{C(off)}$	Output current	$V_i = 0\text{V}; V_{CC} = -50\text{V}$	-	-	-0.5	μA
h_{FE}	DC current gain	$I_o = -5\text{mA}; V_o = -5.0\text{V}$	56	-	-	
R_1	Input resistor		15.4	22.0	28.6	$\text{K}\Omega$
R_2/R_1	Resistor ratio		0.8	1.0	1.2	

Note

1. Pulse test: $t_p \leq 300\mu\text{s}; \delta \leq 0.02$.

RATING CHARACTERISTIC CURVES (CHUMA1GP)

Typical Electrical Characteristics

Fig.1 Input voltage vs. output current (ON characteristics)

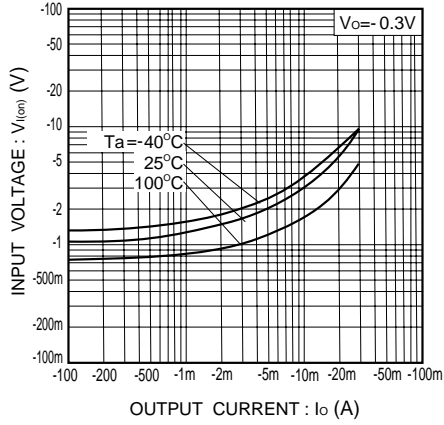

Fig.2 Output current vs. input voltage (OFF characteristics)

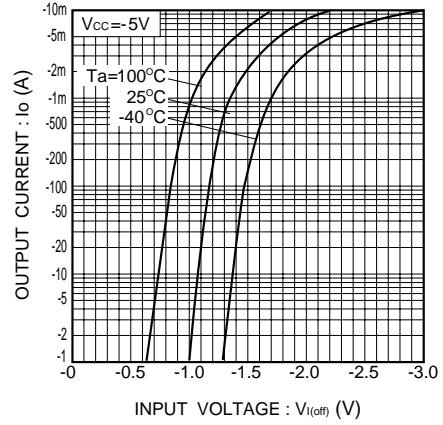

Fig.3 DC current gain vs. output current

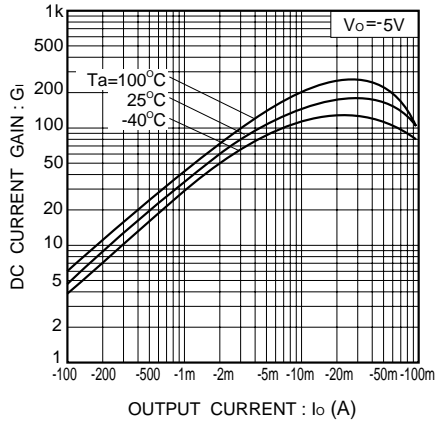

Fig.4 Output voltage vs. output current

