



CHENMKO ENTERPRISE CO.,LTD

Halogens free devices

SURFACE MOUNT
Dual Digital Silicon Transistor
 VOLTAGE 50 Volts CURRENT 100 mAmpere

CHIMB7GP

APPLICATION
 * Switching circuit, Inverter, Interface circuit, Driver circuit.

FEATURE
 * Small surface mounting type. (SC-74/SOT-457)
 * High current gain.
 * Suitable for high packing density.
 * Low collector-emitter saturation.
 * High saturation current capability.
 * Two CHDTA143T chips in a package.
 * Built in bias resistor(R1=4.7kΩ, Typ.)

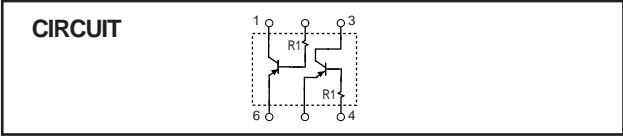
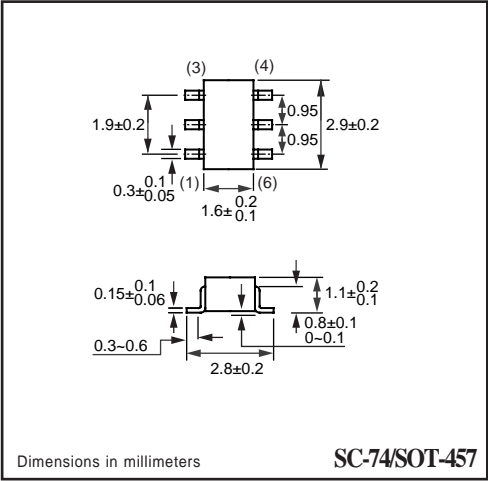
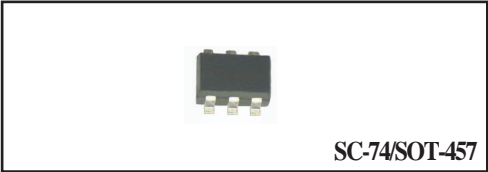

LIMITING VALUES
 In accordance with the Absolute Maximum Rating System (IEC60134).

SYMBOL	PARAMETER	CONDITIONS	VALUE	UNIT
Vcbo	Collector-Base voltage		-50	V
Vceo	Collector-Emitter voltage		-50	V
Vebo	Emitter-Base voltage		-5	V
Ic(Max.)	Collector current		-100	mA
Pd	Power dissipation	T _{amb} ≤ 25 °C, Note 1	300	mW
Tstg	Storage temperature		-55 +150	°C
Tj	Junction temperature		-55 +150	°C
RθJ-s	Thermal resistance , Note 1	junction - soldering point	140	°C/W

Note
 1. Transistor mounted on an FR4 printed-circuit board.

RATING CHARACTERISTIC (CHIMB7GP)

CHARACTERISTICS

$T_{amb} = 25\text{ }^{\circ}\text{C}$ unless otherwise specified.

SYMBOL	PARAMETER	CONDITIONS	MIN.	TYP.	MAX.	UNIT
BVCBO	Collector-Base breakdown voltage	$I_C = -50\mu\text{A}$	-50.0	–	–	V
BVCEO	Collector-Emitter breakdown voltage	$I_C = -1\text{mA}$	-50.0	–	–	V
BVEBO	Emitter-Base breakdown voltage	$I_E = -50\mu\text{A}$	-5.0	–	–	V
VCE(sat)	Collector-Emitter Saturation voltage	$I_C = -5\text{mA}; I_B = -0.25\text{mA}$	–	–	-0.3	V
ICBO	Collector-Base current	$V_{CB} = -50\text{V}$	–	–	-0.5	μA
IEBO	Emitter-Base current	$V_{EB} = -4\text{V}$	–	–	-0.5	μA
hFE	DC current gain	$I_C = -1\text{mA}; V_{CE} = -5.0\text{V}$	100	250	600	
R1	Input resistor		3.29	4.7	6.11	$\text{K}\Omega$
fT	Transition frequency	$I_E = 5\text{mA}, V_{CE} = -10.0\text{V}$ $f = 100\text{MHz}$	–	250	–	MHz

Note

1. Pulse test: $t_p \leq 300\mu\text{s}; \delta \leq 0.02$.

RATING CHARACTERISTIC CURVES (CHIMB7GP)

Typical Electrical Characteristics

Fig.1 DC current gain vs. collector current

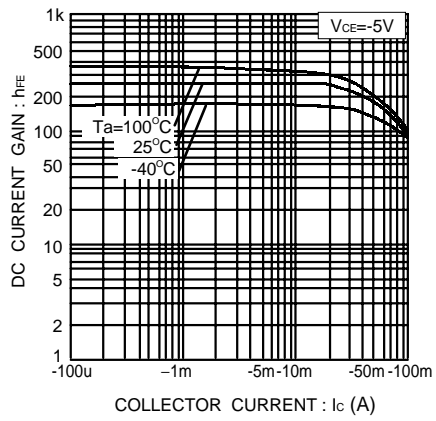

Fig.2 Collector-emitter saturation voltage vs. collector current

