



CHENMKO ENTERPRISE CO.,LTD

Halogens free devices

**SURFACE MOUNT
Dual Digital Silicon Transistor**

VOLTAGE 50 Volts CURRENT 100 mAmpere

CHIMH15GP

APPLICATION

* Switching circuit, Inverter, Interface circuit, Driver circuit.

FEATURE

- * Small surface mounting type. (SC-74/SOT-457)
- * High current gain.
- * Suitable for high packing density.
- * Low collector-emitter saturation.
- * High saturation current capability.
- * Both the CHDTC144T in one package.
- * Built in bias resistor(R1=47kΩ, Typ.)



SC-74/SOT-457

CIRCUIT

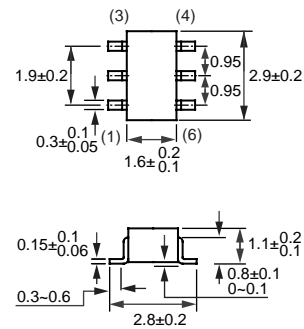
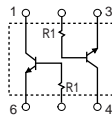

Dimensions in millimeters

SC-74/SOT-457

LIMITING VALUES

In accordance with the Absolute Maximum Rating System (IEC 60134).

SYMBOL	PARAMETER	CONDITIONS	VALUE	UNIT
V _{CBO}	Collector-Base voltage		50	V
V _{CEO}	Collector-Emitter voltage		50	V
V _{EBO}	Emitter-Base voltage		5	V
I _{C(Max.)}	Collector current		100	mA
P _D	Power dissipation	T _{amb} ≤ 25 °C, Note 1	300	mW
T _{STG}	Storage temperature		-55 +150	°C
T _J	Junction temperature		-55 +150	°C
R _{θJ-s}	Thermal resistance , Note 1	junction - soldering point	140	°C/W

Note

1. Transistor mounted on an FR4 printed-circuit board.

RATING CHARACTERISTIC (CHIMH15GP)

CHARACTERISTICS

$T_{amb} = 25\text{ }^{\circ}\text{C}$ unless otherwise specified.

SYMBOL	PARAMETER	CONDITIONS	MIN.	TYP.	MAX.	UNIT
BVCBO	Collector-base breakdown voltage	$I_C=50\mu\text{A}$	50	–	–	V
BVCEO	Collector-emitter breakdown voltage	$I_C=1.0\text{mA}$	50	–	–	V
BVEBO	Emitter-base breakdown voltage	$I_E=50\mu\text{A}$	5.0	–	–	V
ICBO	Collector cutoff current	$V_{CB}=50\text{V}$	–	–	0.5	μA
IEBO	Emitter cutoff current	$V_{EB}=4\text{V}$	–	–	0.5	μA
$V_{CE(sat)}$	Collector-emitter saturation voltage	$I_C/I_B=5\text{mA}/0.5\text{mA}$	–	–	0.3	V
h_{FE}	DC current gain	$I_C=1\text{mA}; V_{CE}=5.0\text{V}$	100	250	600	
R_1	Input resistor		32.9	47	61.1	$\text{K}\Omega$
f_T	Transition frequency	$I_C=5\text{mA}, V_{CE}=10.0\text{V}$ $f=100\text{MHz}$	–	250	–	MHz

Note

1. Pulse test: $t_p \leq 300\mu\text{s}$; $\delta \leq 0.02$.

RATING CHARACTERISTIC CURVES (CHIMH15GP)

Typical Electrical Characteristics

Fig.1 DC current gain vs. collector current

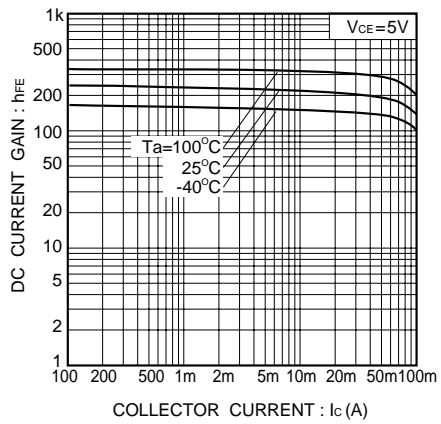

Fig.2 Collector-emitter voltage vs. collector current

