



CHENMKO ENTERPRISE CO.,LTD

Halogens free devices

**SURFACE MOUNT
PNP Digital Silicon Transistor**

VOLTAGE 50 Volts CURRENT 100 mAmpere

CHDTA143ZKGP

APPLICATION

* Switching circuit, Inverter, Interface circuit, Driver circuit.

FEATURE

- * Small surface mounting type. (SOT-23)
- * High current gain.
- * Suitable for high packing density.
- * Low collector-emitter saturation.
- * High saturation current capability.
- * Internal isolated PNP transistors in one package.
- * Built in bias resistor(R1=4.7kΩ, Typ.)

CONSTRUCTION

* One PNP transistors and bias of thin-film resistors in one package.



SOT-23

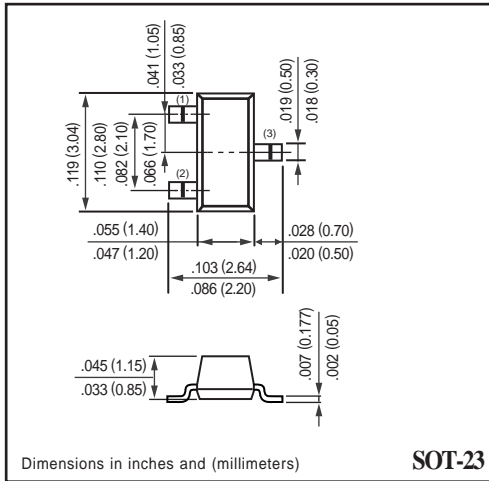

SOT-23

CIRCUIT

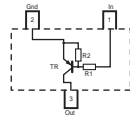

LIMITING VALUES

In accordance with the Absolute Maximum Rating System (IEC 60134).

SYMBOL	PARAMETER	CONDITIONS	MIN.	MAX.	UNIT
V _{CC}	Supply voltage		-	-50	V
V _{IN}	Input voltage		-30	+5	V
I _O	DC Output current		-	-100	mA
I _{C(Max.)}			-	-100	
P _{TOT}	Total power dissipation	T _{amb} ≤ 25 °C, Note 1	-	200	mW
T _{STG}	Storage temperature		-55	+150	°C
T _J	Junction temperature		-	150	°C
Rθ _{J-S}	Thermal resistance	junction - soldering point	-	140	°C/W

Note

1. Transistor mounted on an FR4 printed-circuit board.

RATING CHARACTERISTIC (CHDTA143ZKGP)

CHARACTERISTICS

$T_{amb} = 25\text{ }^{\circ}\text{C}$ unless otherwise specified.

SYMBOL	PARAMETER	CONDITIONS	MIN.	TYP.	MAX.	UNIT
$V_{I(off)}$	Input off voltage	$I_o = -100\mu\text{A}; V_{CC} = -5.0\text{V}$	-0.5	-	-	V
$V_{I(on)}$	Input on voltage	$I_o = -5\text{mA}; V_o = -0.3\text{V}$	-	-	-1.3	V
$V_{O(on)}$	Output voltage	$I_o = -5\text{mA}; I_i = -0.25\text{mA}$	-	-0.1	-0.3	V
I_i	Input current	$V_i = -5\text{V}$	-	-	-1.8	mA
$I_{C(off)}$	Output current	$V_i = 0\text{V}; V_{CC} = -50\text{V}$	-	-	-0.5	μA
h_{FE}	DC current gain	$I_o = -10\text{mA}; V_o = -5.0\text{V}$	80	-	-	
R_1	Input resistor		3.29	4.7	6.11	$\text{K}\Omega$
R_2/R_1	Resistor ratio		8	10	12	
f_T	Transition frequency	$I_C = -5\text{mA}, V_{CE} = -10.0\text{V}$ $f = 100\text{MHz}$	-	250	-	MHz

Note

1. Pulse test: $t_p \leq 300\mu\text{s}; \delta \leq 0.02$.

RATING CHARACTERISTIC CURVES (CHDTA143ZKGP)

Typical Electrical Characteristics

Fig.1 Input voltage vs. output current (ON characteristics)

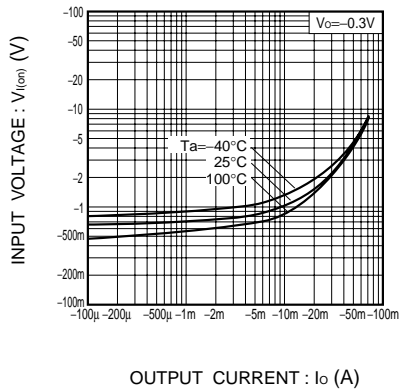

Fig.2 Output current vs. input voltage (OFF characteristics)

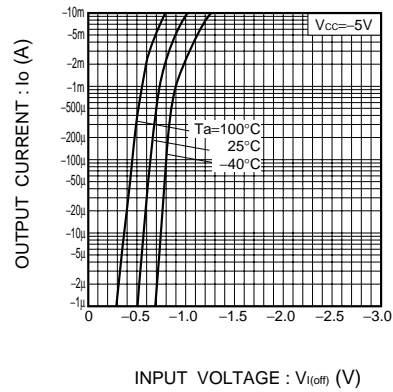

Fig.3 DC current gain vs. output current

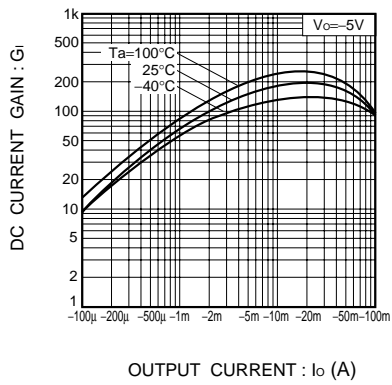

Fig.4 Output voltage vs. output current

