



CHENMKO ENTERPRISE CO.,LTD

Halogens free devices

**SURFACE MOUNT
PNP Digital Silicon Transistor**

VOLTAGE 50 Volts CURRENT 100 mAmpere

CHDTA114GUGP

APPLICATION

* Switching circuit, Inverter, Interface circuit, Driver circuit.

FEATURE

- * Small surface mounting type. (SC-70/SOT-323)
- * High current gain.
- * Suitable for high packing density.
- * Low collector-emitter saturation.
- * High saturation current capability.
- * Internal isolated PNP transistors in one package.
- * Built in bias resistor(R1=10kΩ, Typ.)

CONSTRUCTION

* One PNP transistors and bias of thin-film resistors in one package.

MARKING

GU1

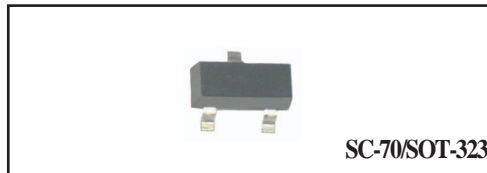

SC-70/SOT-323

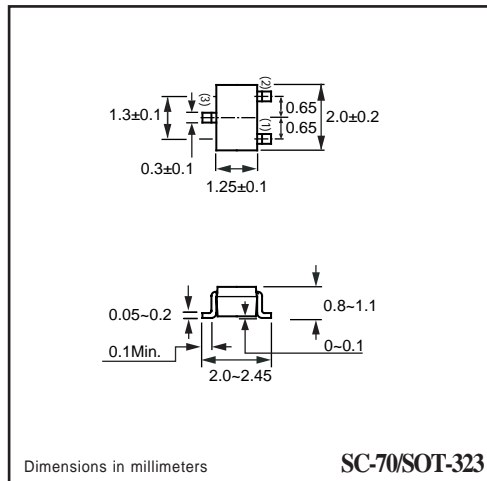

CIRCUIT

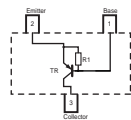

LIMITING VALUES

In accordance with the Absolute Maximum Rating System.

SYMBOL	PARAMETER	CONDITIONS	VALUE	UNIT
Vcbo	Collector-Base voltage		-50	V
Vceo	Collector-Emitter voltage		-50	V
Vebo	Emitter-Base voltage		-5	V
Ic	Collector current		-100	mA
Pc	Collector Power dissipation	T _{amb} ≤ 25 °C, Note 1	200	mW
Tstg	Storage temperature		150	°C
Tj	Junction temperature		-55 +150	°C
RθJ-s	Thermal resistance , Note 1	junction - soldering point	140	°C/W

Note

1. Transistor mounted on an FR4 printed-circuit board.

RATING CHARACTERISTIC (CHDTA114GUGP)

CHARACTERISTICS

$T_{amb} = 25\text{ }^{\circ}\text{C}$ unless otherwise specified.

SYMBOL	PARAMETER	CONDITIONS	MIN.	TYP.	MAX.	UNIT
BVCBO	Collector-Base breakdown voltage	$I_C = -50\mu\text{A}$	-50.0	-	-	V
BVCEO	Collector-Emitter breakdown voltage	$I_C = -1\text{mA}$	-50.0	-	-	V
BVEBO	Emitter-Base breakdown voltage	$I_E = -720\mu\text{A}$	-5.0	-	-	V
VCE(sat)	Collector-Emitter Saturation voltage	$I_C = -10\text{mA}; I_B = -0.5\text{mA}$	-	-	-0.3	V
ICBO	Collector-Base current	$V_{CB} = -50\text{V}$	-	-	-0.5	μA
IEBO	Emitter-Base current	$V_{EB} = -4\text{V}$	-	-	-580	μA
hFE	DC current gain	$I_C = -5\text{mA}; V_{CE} = -5.0\text{V}$	30	-	-	
R1	Input resistor		7	10	13	$\text{K}\Omega$
fT	Transition frequency	$I_E = 5\text{mA}, V_{CE} = -10.0\text{V}$ $f = 100\text{MHz}$	-	250	-	MHz

Note

1. Pulse test: $t_p \leq 300\mu\text{s}; \delta \leq 0.02$.