



CHENMKO ENTERPRISE CO.,LTD

Halogens free devices

**SURFACE MOUNT
Dual Silicon Transistor**

VOLTAGE 50 Volts CURRENT 150 mAmpere

CHIMX1GP

APPLICATION

* Small Signal Amplifier .

FEATURE

- * Small surface mounting type. (SC-74/SOT-457)
- * Low saturation voltage $V_{CE(sat)}=0.4V(max.)(I_c=50mA)$
- * Low cob. $C_{ob}=2.0pF(Typ.)$
- * $P_c= 150mW$ (Total),120mW per element must not be exceeded.
- * High saturation current capability.
- * Two the 2SC2412K in one package.
- * NPN Silicon Transistor

MARKING

* IX1

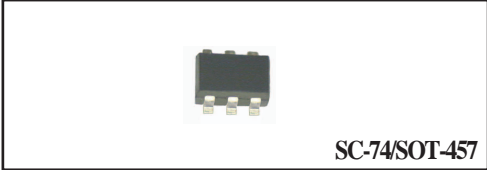

SC-74/SOT-457

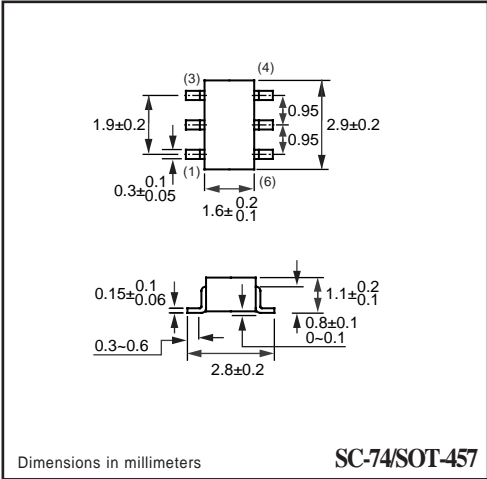

CIRCUIT

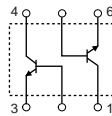

2SC2412K LIMITING VALUES

MAXIMUM RATINGS (At $T_A = 25^{\circ}C$ unless otherwise noted)

RATINGS	CONDITION	SYMBOL	MIN.	MAX.	UNITS
Collector - Base Voltage	Open Emitter	V_{CBO}	-	60	Volts
Collector - Emitter Voltage	Open Base	V_{CEO}	-	50	Volts
Emitter - Base Voltage	Open Collector	V_{EBO}	-	7	Volts
Collector Current DC		I_c	-	150	mAmps
Peak Collector Current		I_{CM}	-	150	mAmps
Peak Base Current		I_{BM}	-	15	mAmps
Total Power Dissipation	$T_A \leq 25^{\circ}C$; Note 1	P_{TOT}	-	150	mW
Storage Temperature		T_{STG}	-55	+150	$^{\circ}C$
Junction Temperature		T_J	-	+150	$^{\circ}C$
Operating Ambient Temperature		T_{AMB}	-55	+150	$^{\circ}C$

Note

1. Transistor mounted on ceramic substrate 50mmX50mmX0.8t.

RATING CHARACTERISTIC CURVES (CHIMX1GP)

2SC2412K CHARACTERISTICS

ELECTRICAL CHARACTERISTICS (At $T_A = 25^{\circ}\text{C}$ unless otherwise noted)

PARAMETERS	CONDITION	SYMBOL	MIN.	TYPE	MAX.	UNITS
Collector-base breakdown voltage	$I_C=50\mu\text{A}$	BV_{CBO}	60	-	-	Volts
Collector-emitter breakdown voltage	$I_C=1\text{mA}$	BV_{CEO}	50	-	-	Volts
Emitter-base breakdown voltage	$I_E=50\mu\text{A}$	BV_{EBO}	7	-	-	Volts
Collector Cut-off Current	$I_E=0; V_{CB}=60\text{V}$	I_{CBO}	-	-	0.1	
Emitter Cut-off Current	$I_C=0; V_{EB}=7\text{V}$	I_{CEO}	-	-	0.1	μA
DC Current Gain	$V_{CE}=6\text{V}$ $I_C=1\text{mA}$	h_{FE}	120	-	560	
Collector-Emitter Saturation Voltage	$I_C=50\text{mA}; I_B=5\text{mA}$	V_{CEsat}	-	-	0.4	Volts
Output Collector Capacitance	$I_E=I_E=0; V_{CB}=12\text{V};$ $f=1\text{MHz}$	C_{ob}	-	2	3.5	pF
Transition Frequency	$I_C=2\text{mA}; V_{CE}=12\text{V};$ $f=100\text{MHz}$	f_T	-	180	-	MHz

RATING CHARACTERISTIC CURVES (CHIMX1GP)

2SC2412K Typical Electrical Characteristics

Fig.1 Grounded emitter propagation characteristics

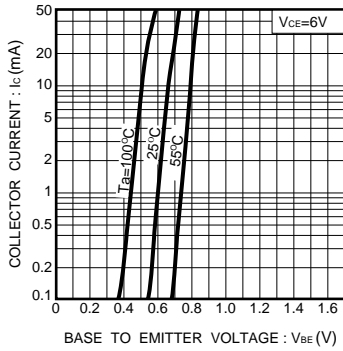

Fig.2 Grounded emitter output characteristics

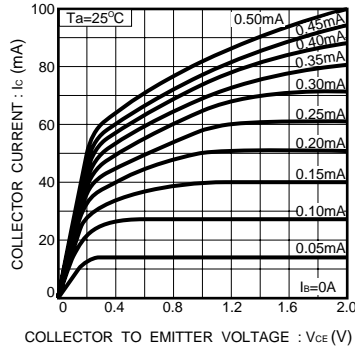

Fig.3 DC current gain vs. collector current (1)

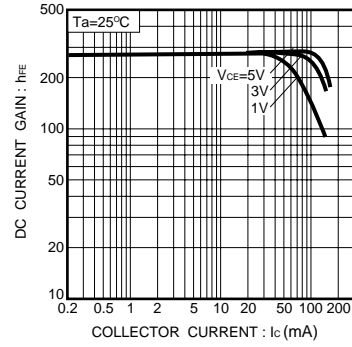

Fig.4 DC current gain vs. collector current (2)

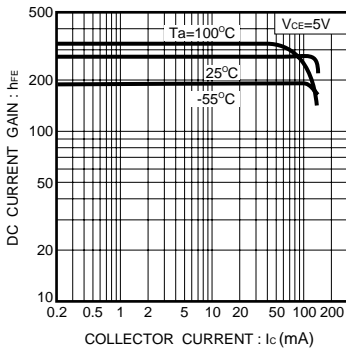

Fig.5 Collector-emitter saturation voltage vs. collector current

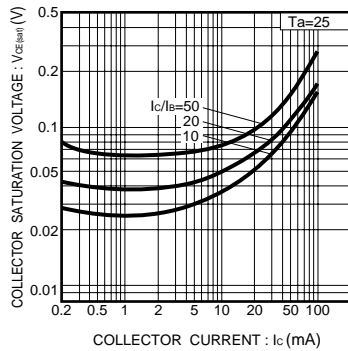

Fig.6 Collector-emitter saturation voltage vs. collector current

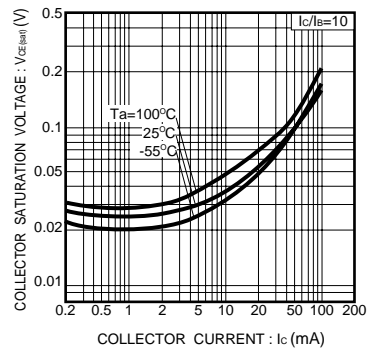

Fig.7 Gain bandwidth product vs. emitter current

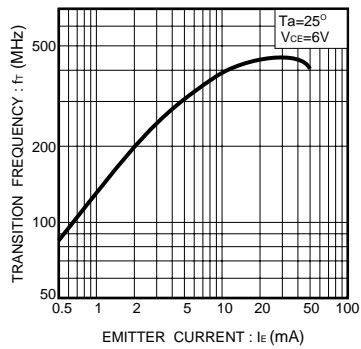

Fig.8 Base-collector time constant vs. emitter current

