



CHENMKO ENTERPRISE CO.,LTD

Halogens free devices

**SURFACE MOUNT
General Purpose NPN Transistor**

VOLTAGE 50 Volts CURRENT 0.15 Ampere

2SC4617GP

APPLICATION
* Small Power Amplifier .

FEATURE
* Surface mount package. (SC-75/SOT-416)
* Low saturation voltage $V_{CE(sat)}=0.4V(max.)(I_c=50mA)$
* Low cob. $C_{ob}=2.0pF(Typ.)$
* $P_c= 150mW$ (Collector power dissipation).

CONSTRUCTION
* NPN Silicon Transistor
* Epitaxial planner type

MARKING
* hFE(Q): UX
* hFE(R): UY
* hFE(S): UZ

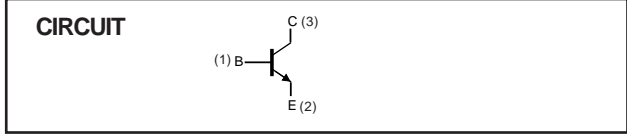
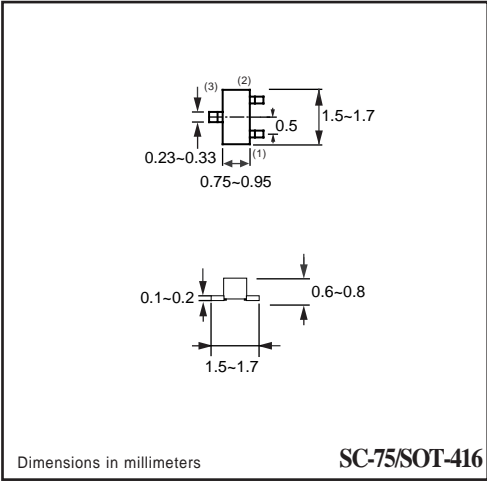
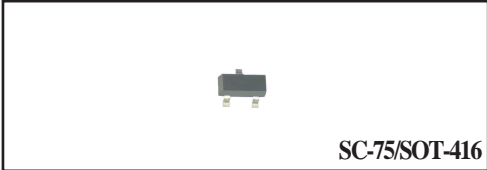

MAXIMUM RATINGS (At $T_A = 25^{\circ}C$ unless otherwise noted)

RATINGS	CONDITION	SYMBOL	MIN.	MAX.	UNITS
Collector - Base Voltage	Open Emitter	V_{CB0}	-	60	Volts
Collector - Emitter Voltage	Open Base	V_{CE0}	-	50	Volts
Emitter - Base Voltage	Open Collector	V_{EB0}	-	7	Volts
Collector Current DC		I_c	-	150	mAmps
Collector Power Dissipation	$T_A \leq 25^{\circ}C$	P_{TOT}	-	150	mW
Storage Temperature		T_{STG}	-55	+150	$^{\circ}C$
Junction Temperature		T_J	-	+150	$^{\circ}C$

Note

1. Transistor mounted on ceramic substrate 50mmX50mmX0.8t.
2. Measured at Pulse Width 300 us, Duty Cycle 2%.

RATING CHARACTERISTICS (2SC4617GP)

ELECTRICAL CHARACTERISTICS (At $T_A = 25^\circ\text{C}$ unless otherwise noted)

PARAMETERS	CONDITION	SYMBOL	MIN.	TYPE	MAX.	UNITS
Collector Cut-off Current	$I_E=0; V_{CB}=60\text{V}$	I_{CBO}	-	-	0.1	μA
Emitter Cut-off Current	$I_C=0; V_{EB}=7\text{V}$	I_{CEO}	-	-	0.1	μA
DC Current Gain	$V_{CE}=6\text{V}$; Note 1 $I_C=1\text{mA}$; Note 2	h_{FE}	120	-	560	
Collector-Emitter Saturation Voltage	$I_C=50\text{mA}; I_B=5\text{mA}$	V_{CEsat}	-	-	0.4	Volts
Collector-Emitter Breakdown Voltage	$I_C=1\text{mA}$	V_{CEO}	50	-	-	Volts
Output Collector Capacitance	$I_E=I_C=0; V_{CB}=12\text{V}; f=1\text{MHz}$	C_{ob}	-	2.0	3.5	pF
Transition Frequency	$I_E=2\text{mA}; V_{CE}=12\text{V}; f=100\text{MHz}$	f_T	-	180	-	MHz

Note :

1. Pulse test: $t_p \leq 300\mu\text{Sec}$; $\delta \leq 0.02$.
2. h_{FE} : Classification Q: 120 to 270, R: 180 to 390, S: 270 to 560

RATING CHARACTERISTIC CURVES (2SC4617GP)

Fig.1 Grounded emitter propagation characteristics

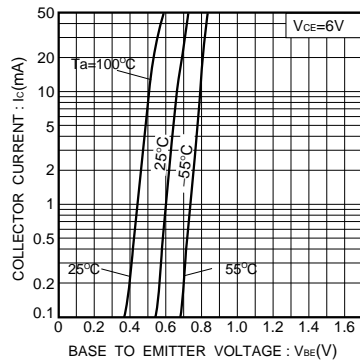

Fig.2 Grounded emitter output characteristics (1)

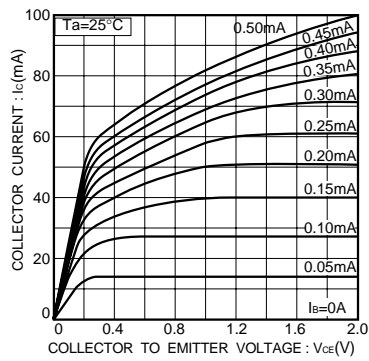
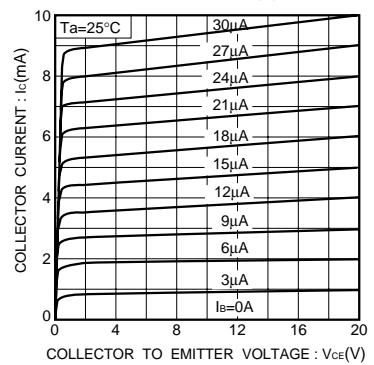

Fig.3 Grounded emitter output characteristics (2)



RATING CHARACTERISTIC CURVES (2SC4617GP)

Fig.4 Collector-emitter saturation voltage vs. collector current

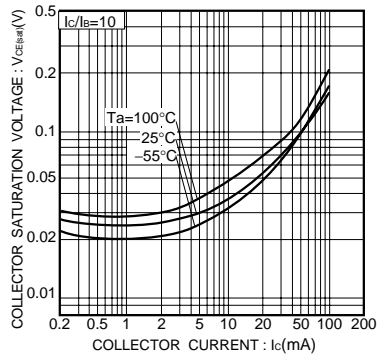

Fig.5 DC current gain vs. collector current

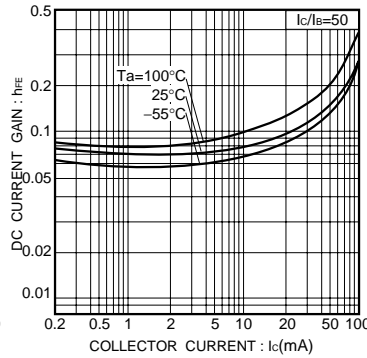

Fig.6 Gain bandwidth product vs. emitter current

