

2N6107 2N6109 2N6111 PNP
 2N6288 2N6290 2N6292 NPN

**COMPLEMENTARY
 SILICON POWER TRANSISTORS**

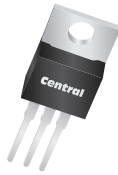

TO-220 CASE



www.centrasemi.com

DESCRIPTION:

The CENTRAL SEMICONDUCTOR 2N6107, 2N6288 series types are complementary silicon power transistors, manufactured by the epitaxial base process, designed for general purpose power amplifier and switching applications.

MARKING: FULL PART NUMBER

MAXIMUM RATINGS: ($T_C=25^\circ\text{C}$)

Collector-Base Voltage
 Collector-Emitter Voltage
 Emitter-Base Voltage
 Continuous Collector Current
 Peak Collector Current
 Continuous Base Current
 Power Dissipation
 Operating and Storage Junction Temperature
 Thermal Resistance

SYMBOL	2N6111	2N6109	2N6107	UNITS
	2N6288	2N6290	2N6292	
V_{CBO}	40	60	80	V
V_{CEO}	30	50	70	V
V_{EBO}		5.0		V
I_C		7.0		A
I_{CM}		10		A
I_B		3.0		A
P_D		40		W
T_J, T_{stg}		-65 to +150		$^\circ\text{C}$
θ_{JC}		3.13		$^\circ\text{C/W}$

ELECTRICAL CHARACTERISTICS: ($T_C=25^\circ\text{C}$ unless otherwise noted)

SYMBOL	TEST CONDITIONS	MIN	MAX	UNITS
I_{CEV}	$V_{CE}=\text{Rated } V_{CEO}, V_{EB}=1.5\text{V}$		100	μA
I_{CEV}	$V_{CE}=\text{Rated } V_{CEO}, V_{EB}=1.5\text{V}, T_C=150^\circ\text{C}$		2.0	mA
I_{CEO}	$V_{CE}=20\text{V}$ (2N6111, 2N6288)		1.0	mA
I_{CEO}	$V_{CE}=40\text{V}$ (2N6109, 2N6290)		1.0	mA
I_{CEO}	$V_{CE}=60\text{V}$ (2N6107, 2N6292)		1.0	mA
I_{EBO}	$V_{EB}=5.0\text{V}$		1.0	mA
BV_{CEO}	$I_C=100\text{mA}$ (2N6111, 2N6288)	30		V
BV_{CEO}	$I_C=100\text{mA}$ (2N6109, 2N6290)	50		V
BV_{CEO}	$I_C=100\text{mA}$ (2N6107, 2N6292)	70		V
$V_{CE(SAT)}$	$I_C=7.0\text{A}, I_B=3.0\text{A}$		3.5	V
$V_{BE(ON)}$	$V_{CE}=4.0\text{V}, I_C=7.0\text{A}$		3.0	V
h_{FE}	$V_{CE}=4.0\text{V}, I_C=2.0\text{A}$ (2N6107, 2N6292)	30	150	
h_{FE}	$V_{CE}=4.0\text{V}, I_C=2.5\text{A}$ (2N6109, 2N6290)	30	150	
h_{FE}	$V_{CE}=4.0\text{V}, I_C=3.0\text{A}$ (2N6111, 2N6288)	30	150	
h_{FE}	$V_{CE}=4.0\text{V}, I_C=7.0\text{A}$	2.3		
h_{fe}	$V_{CE}=4.0\text{V}, I_C=0.5\text{A}, f=50\text{kHz}$	20		
f_T	$V_{CE}=4.0\text{V}, I_C=0.5\text{A}, f=1.0\text{MHz}$	4.0		MHz
C_{ob}	$V_{CB}=10\text{V}, I_E=0, f=1.0\text{MHz}$		250	pF

R1 (10-April 2013)

2N6107 2N6109 2N6111 PNP
 2N6288 2N6290 2N6292 NPN



**COMPLEMENTARY
 SILICON POWER TRANSISTORS**

TO-220 CASE - MECHANICAL OUTLINE

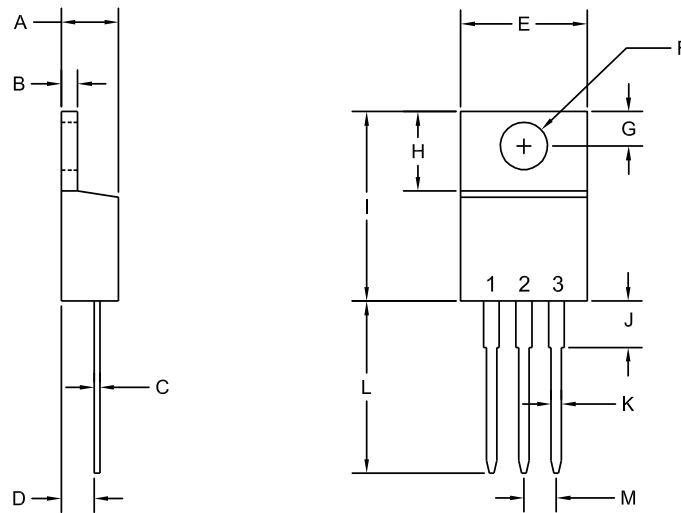

R2

LEAD CODE:

- 1) Base
- 2) Collector
- 3) Emitter
- Tab) Collector

**MARKING:
 FULL PART NUMBER**

SYMBOL	DIMENSIONS		DIMENSIONS	
	INCHES		MILLIMETERS	
	MIN	MAX	MIN	MAX
A	0.170	0.190	4.31	4.82
B	0.045	0.055	1.15	1.39
C	0.013	0.026	0.33	0.65
D	0.083	0.107	2.10	2.72
E	0.394	0.417	10.01	10.60
F (DIA)	0.140	0.157	3.55	4.00
G	0.100	0.118	2.54	3.00
H	0.230	0.270	5.85	6.85
I	0.560	0.625	14.23	15.87
J	-	0.250	-	6.35
K	0.025	0.038	0.64	0.96
L	0.500	0.579	12.70	14.70
M	0.090	0.110	2.29	2.79

TO-220 (REV: R2)

R1 (10-April 2013)