

# High-Frequency Amplifier Transistor

**L2SC4226T1G**  
**S-L2SC4226T1G**

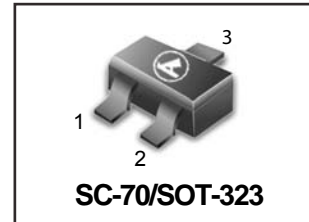
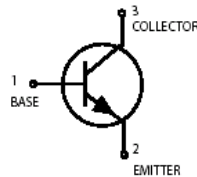

## DESCRIPTION

The L2SC4226T1G is a low supply voltage transistor designed for VHF, UHF low noise amplifier.

It is suitable for a high density surface mount assembly since the transistor has been applied small mini mold package.

We declare that the material of product compliance with RoHS requirements.

S- Prefix for Automotive and Other Applications Requiring Unique Site and Control Change Requirements; AEC-Q101 Qualified and PPAP Capable.

## FEATURES

- Low Noise  
NF = 1.2 dB TYP. @ f = 1 GHz, V<sub>CE</sub> = 3 V, I<sub>c</sub> = 7 mA
- High Gain  
 $|S_{21e}|^2 = 9.0$  dB TYP. @ f = 1 GHz, V<sub>CE</sub> = 3 V, I<sub>c</sub> = 7 mA
- Small Mini Mold Package  
EIAJ: SC-70

## Driver Marking

L2SC4226T1G;S-L2SC4226T1G=R2

## Ordering Information

Device	Marking	Shipping
L2SC4226T1G S-L2SC4226T1G	R2	3000/Tape&Reel
L2SC4226T3G S-L2SC4226T3G	R2	10000/Tape&Reel

**ABSOLUTE MAXIMUM RATINGS (T<sub>A</sub> = 25 °C)**

Collector to Base Voltage	V <sub>CBO</sub>	20	V
Collector to Emitter Voltage	V <sub>CEO</sub>	12	V
Emitter to Base Voltage	V <sub>EBO</sub>	3	V
Collector Current	I <sub>C</sub>	100	mA
Total Power Dissipation	P <sub>T</sub>	150	mW
Junction Temperature	T <sub>J</sub>	150	°C
Storage Temperature	T <sub>stg</sub>	-65 to +150	°C

**ELECTRICAL CHARACTERISTICS (T<sub>A</sub> = 25 °C)**

CHARACTERISTIC	SYMBOL	MIN.	TYP.	MAX.	UNIT	TEST CONDITION
Collector Cutoff Current	I <sub>CBO</sub>			1.0	μA	V <sub>CB</sub> = 10 V, I <sub>E</sub> = 0
Emitter Cutoff Current	I <sub>EBO</sub>			1.0	μA	V <sub>EB</sub> = 1 V, I <sub>C</sub> = 0
DC Current Gain	h <sub>FE</sub>	40	110	250		V <sub>CE</sub> = 3 V, I <sub>C</sub> = 7 mA* <sup>1</sup>
Gain Bandwidth Product	f <sub>T</sub>	3.0	4.5		GHz	V <sub>CE</sub> = 3 V, I <sub>C</sub> = 7 mA
Feed back Capacitance	C <sub>re</sub>		0.7	1.5	pF	V <sub>CE</sub> = 3 V, I <sub>E</sub> = 0, f = 1 MHz* <sup>2</sup>
Insertion Power Gain	S <sub>21e</sub>   <sup>2</sup>	7	9		dB	V <sub>CE</sub> = 3 V, I <sub>C</sub> = 7 mA, f = 1 GHz
Noise Figure	NF		1.2	2.5	dB	V <sub>CE</sub> = 3 V, I <sub>C</sub> = 7 mA, f = 1 GHz

\*1 Pulse Measurement ; PW ≤ 350 μs, Duty Cycle ≤ 2 % Pulsed.

\*2 Measured with 3 terminals bridge, Emitter and Case should be grounded.

**TYPICAL CHARACTERISTICS (T<sub>A</sub> = 25 °C)**

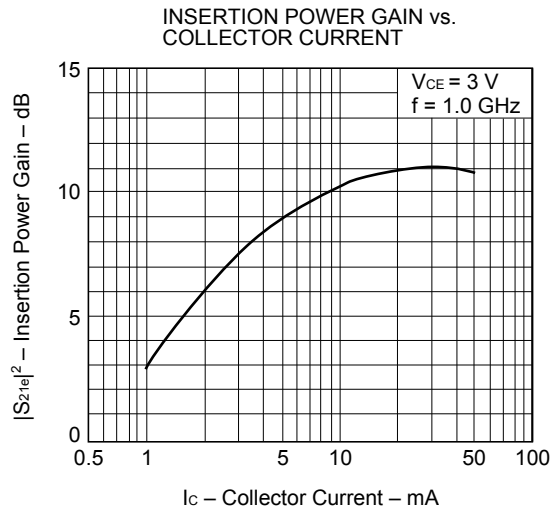
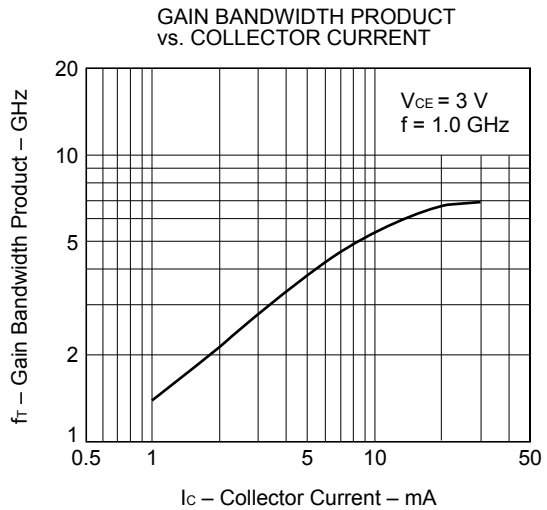
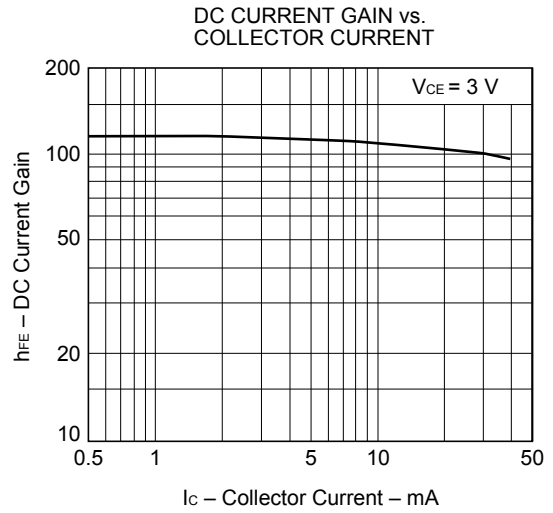
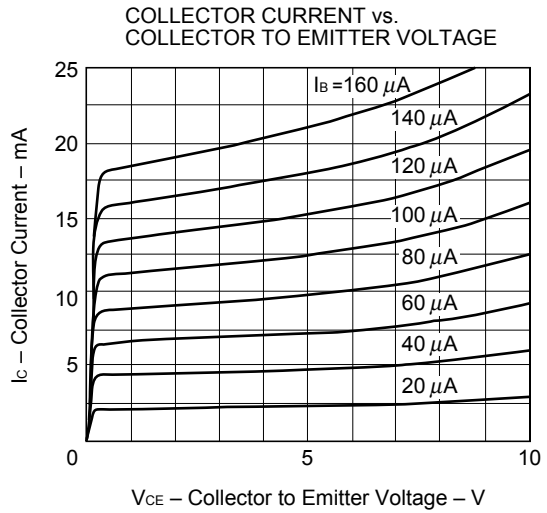
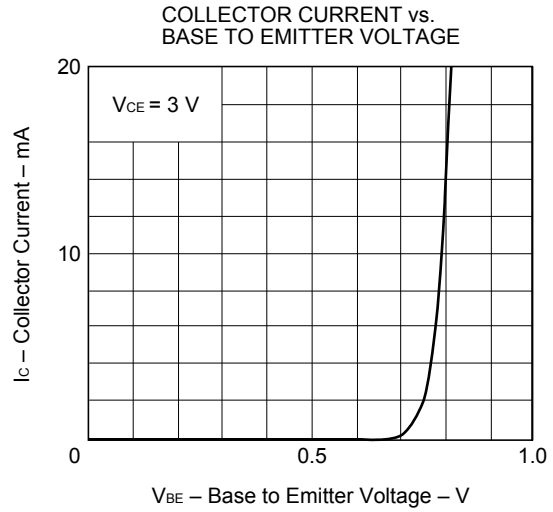
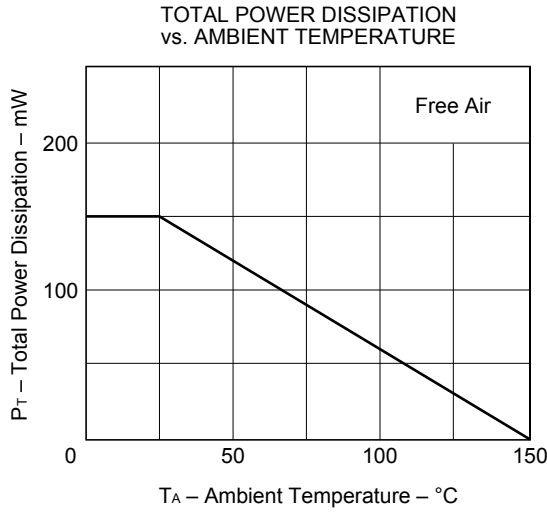

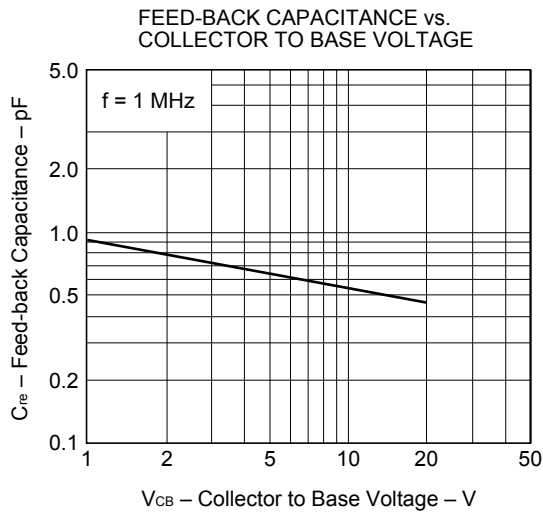
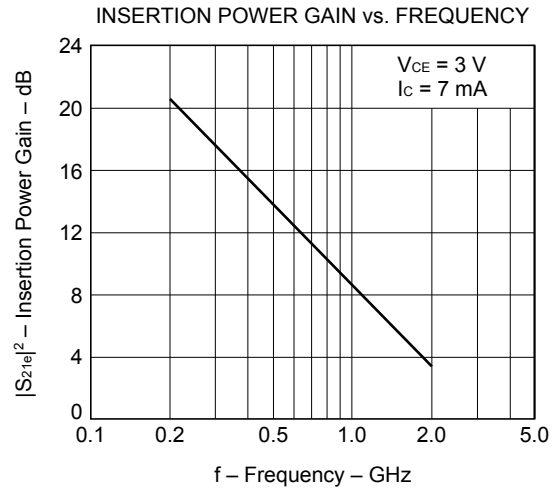
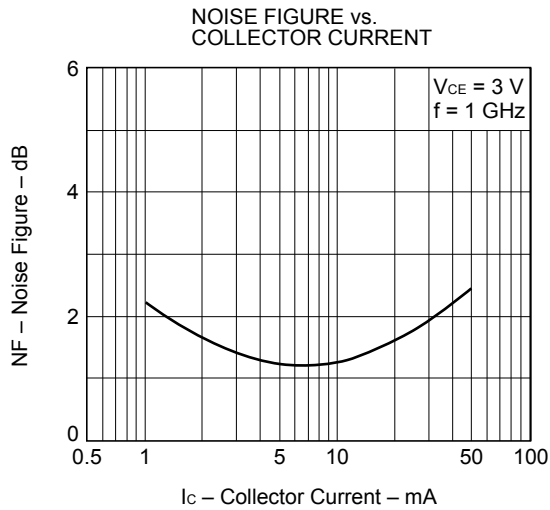

SC-70 / SOT-323

NOTES:

1. DIMENSIONING AND TOLERANCING PER ANSI Y14.5M, 1982.
2. CONTROLLING DIMENSION: INCH.

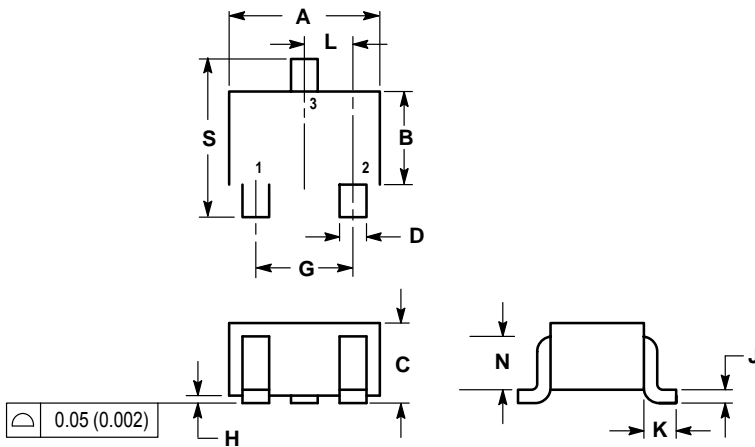

DIM	INCHES		MILLIMETERS	
	MIN	MAX	MIN	MAX
A	0.071	0.087	1.80	2.20
B	0.045	0.053	1.15	1.35
C	0.032	0.040	0.80	1.00
D	0.012	0.016	0.30	0.40
G	0.047	0.055	1.20	1.40
H	0.000	0.004	0.00	0.10
J	0.004	0.010	0.10	0.25
K	0.017 REF		0.425 REF	
L	0.026 BSC		0.650 BSC	
N	0.028 REF		0.700 REF	
S	0.079	0.095	2.00	2.40

- PIN 1. BASE  
 2. EMITTER  
 3. COLLECTOR

