

20A Avg.

60 Volts

SBD

C20T06QH

■最大定格 Maximum Ratings

Item	Symbol	Conditions	Unit		
くり返しピーク逆電圧 Repetitive Peak Reverse Voltage	V_{RRM}	60	V		
くり返しピークサージ逆電圧 Repetitive Peak Surge Reverse Voltage	V_{RRSM}	65 pulse width $\leq 1 \mu s$ duty $\leq 1/50$	V		
平均整流電流 Average Rectified Forward Current	I_O	50Hz, 正弦全波通電抵抗負荷 50Hz Full Sine Wave Resistive Load	$T_c = 124^\circ C$	20	A
実効順電流 R.M.S. Forward Current	$I_F(RMS)$	22.2	A		
サージ順電流 Surge Forward Current	I_{FSM}	180 50Hz正弦全波, 1サイクル, 非くり返し 50Hz Full Sine Wave, 1cycle, Non-repetitive	A		
動作接合温度範囲 Operating Junction Temperature Range	T_{jw}	-40 ~ +150	$^\circ C$		
保存温度範囲 Storage Temperature Range	T_{stg}	-40 ~ +150	$^\circ C$		

■OUTLINE DRAWING(mm)

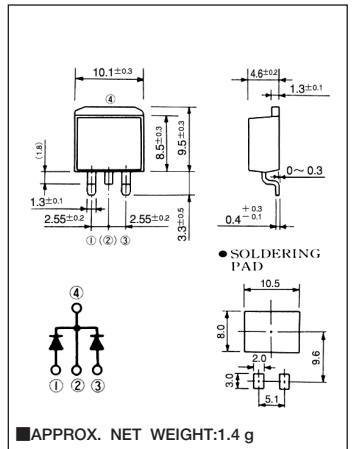

■電氣的・熱的特性 Electrical/Thermal Characteristics

Item	Symbol	Conditions	Min.	Typ.	Max.	Unit
ピーク逆電流 Peak Reverse Current	I_{RM}	$T_j = 25^\circ C, V_{RM} = V_{RRM}$, 一素子あたり Per Diode	—	—	1	mA
ピーク順電圧 Peak Forward Voltage	V_{FM}	$T_j = 25^\circ C, I_{FM} = 10A$, 一素子あたり Per Diode	—	—	0.68	V
熱抵抗 Thermal Resistance	$R_{th(j-c)}$	接合部・ケース間 Junction to Case	—	—	1.5	$^\circ C/W$

■定格・特性曲線

