

2A Avg.

60 Volts

SBD

EA20QC06

最大定格 Maximum Ratings

| Item | Symbol | Conditions | Unit |
|----------------------------------------------------|--------------|------------------------------------------------------------------------|-------------------------------------|
| くり返しピーク逆電圧 Repetitive Peak Reverse Voltage | V_{RRM} | 60 | V |
| 非くり返しピーク逆電圧 Non-repetitive Peak Reverse Voltage | V_{RSM} | 65 | V |
| 平均整流電流 Average Rectified Forward Current | I_O | 50Hz、正弦全波通電抵抗負荷 50Hz Full Sine Wave Resistive Load | $T_a=28^\circ\text{C}$ 1.4 A |
| | | | $T_c=135^\circ\text{C}$ 2.0 A |
| 実効順電流 R.M.S. Forward Current | $I_{F(RMS)}$ | 2.22 | A |
| サージ順電流 Surge Forward Current | I_{FSM} | 20 50Hz正弦全波、1サイクル、非くり返し 50Hz Full Sine Wave, 1cycle, Non-repetitive | A |
| 動作接合温度範囲 Operating Junction Temperature Range | T_{jw} | -40~+150 | $^\circ\text{C}$ |
| 保存温度範囲 Storage Temperature Range | T_{stg} | -40~+150 | $^\circ\text{C}$ |

OUTLINE DRAWING(mm)

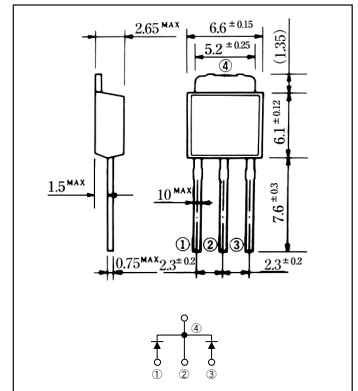

APPROX. NET WEIGHT:0.35g

電氣的・熱的特性 Electrical/Thermal Characteristics

| Item | Symbol | Conditions | Min. | Typ. | Max. | Unit |
|--------------------------------|---------------|-------------------------------------------------------------------|------|------|------|---------------------------|
| ピーク逆電流 Peak Reverse Current | I_{RM} | $T_j=25^\circ\text{C}$, $V_{RM}=V_{RRM}$, 一素子あたり Per Diode | — | — | 1 | mA |
| ピーク順電圧 Peak Forward Voltage | V_{FM} | $T_j=25^\circ\text{C}$, $I_{FM}=1\text{A}$, 一素子あたり Per Diode | — | — | 0.58 | V |
| 熱抵抗 Thermal Resistance | $R_{th(j-a)}$ | 接合部・周囲間 Junction to Ambient | — | — | 80 | $^\circ\text{C}/\text{W}$ |
| | $R_{th(j-c)}$ | 接合部・ケース間 Junction to Case | — | — | 6 | $^\circ\text{C}/\text{W}$ |

* Print Land=20×20mm

定格・特性曲線

