

5A Avg.

150 Volts

SBD

ESH05A15

■最大定格 Maximum Ratings

Item	Symbol	Conditions	Unit	
くり返しピーク逆電圧 Repetitive Peak Reverse Voltage	V_{RRM}	150	V	
平均整流電流*1 Average Rectified Forward Current	I_O	50Hz、正弦半波通電抵抗負荷 50Hz Half Sine Wave Resistive Load	1.6 5.0	A A
実効順電流*1 R.M.S. Forward Current	$I_F(RMS)$	7.85	A	
サージ順電流*1 Surge Forward Current	I_{FSM}	130 50Hz正弦半波、1サイクル、非くり返し 50Hz Half Sine Wave, 1cycle, Non-repetitive	A	
動作接合温度範囲 Operating Junction Temperature Range	T_{jw}	-40~+150	°C	
保存温度範囲 Storage Temperature Range	T_{stg}	-40~+150	°C	

■OUTLINE DRAWING(mm)

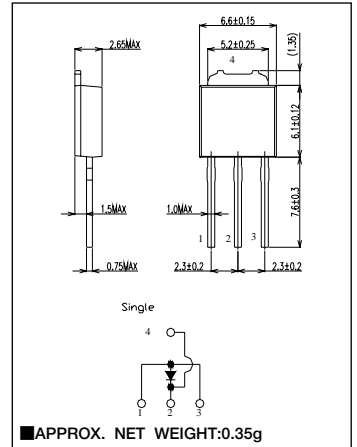

■電氣的・熱的特性 Electrical/Thermal Characteristics

Item	Symbol	Conditions	Min.	Typ.	Max.	Unit
ピーク逆電流 Peak Reverse Current	I_{RM}	$T_j=25^{\circ}C, V_{RM}=V_{RRM}$	—	—	1	mA
ピーク順電圧 Peak Forward Voltage	V_{FM}	$T_j=25^{\circ}C, I_{FM}=5A$	—	—	0.88	V
熱抵抗 Thermal Resistance	$R_{th(j-a)}$	接合部・周囲間 Junction to Ambient	—	—	80	°C/W
	$R_{th(j-c)}$	接合部・ケース間 Junction to Case	—	—	5	°C/W

*1: アノード電極1, 3番端子通電時/Anode Terminals 1 and 3 Connected
*2: プリント基板実装時/P.C.Board mounted Print Land=20×20mm

■定格・特性曲線

