

20A Avg.

150 Volts

SBD

FCH20U15

■最大定格 Maximum Ratings

Item	Symbol	Conditions	Unit
くり返しピーク逆電圧 Repetitive Peak Reverse Voltage	V_{RRM}	150	V
平均整流電流 Average Rectified Forward Current	I_O	50Hz、正弦全波通電抵抗負荷 50Hz Full Sine Wave Resistive Load	20 A
実効順電流 R.M.S. Forward Current	$I_F(RMS)$	22.2	A
サージ順電流 Surge Forward Current	I_{FSM}	180 50Hz正弦全波, 1サイクル, 非くり返し 50Hz Full Sine Wave, 1cycle, Non-repetitive	A
動作接合温度範囲 Operating Junction Temperature Range	T_{jw}	-40~+150	°C
保存温度範囲 Storage Temperature Range	T_{stg}	-40~+150	°C
締付トルク Mounting torque	F_{tor}	推奨値 Recommended Value	0.5 N·m

■OUTLINE DRAWING(mm)

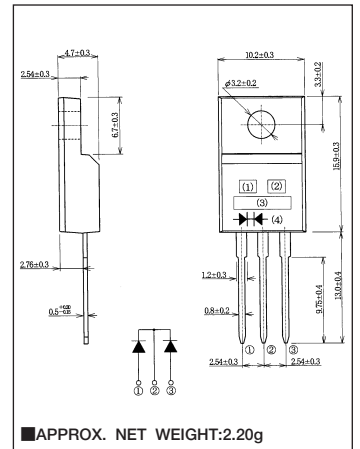

■電氣的・熱的特性 Electrical/Thermal Characteristics

Item	Symbol	Conditions	Min.	Typ.	Max.	Unit
ピーク逆電流 Peak Reverse Current	I_{RM}	$T_j=25^\circ\text{C}$, $V_{RM}=V_{RRM}$, 一素子あたり Per Diode	—	—	1	mA
ピーク順電圧 Peak Forward Voltage	V_{FM}	$T_j=25^\circ\text{C}$, $I_{FM}=10\text{A}$, 一素子あたり Per Diode	—	—	0.90	V
熱抵抗 Thermal Resistance	$R_{th(j-c)}$	接合部・ケース間 Junction to Case	—	—	1.5	°C/W
	$R_{th(c-f)}$	ケース・フィン間 Case to Fin	—	—	1.5	°C/W

■定格・特性曲線

