

Features

- 60V/5A,
 $R_{DS(ON)} = 60m\Omega$ (Typ.) @ $V_{GS} = 10V$
 $R_{DS(ON)} = 70m\Omega$ (Typ.) @ $V_{GS} = 4.5V$
- Super High Dense Cell Design
- Reliable and Rugged
- ESD Protected
- Lead Free and Green Available

Applications

- Power Management
- Switch Applications

Absolute Maximum Ratings

Pin Description

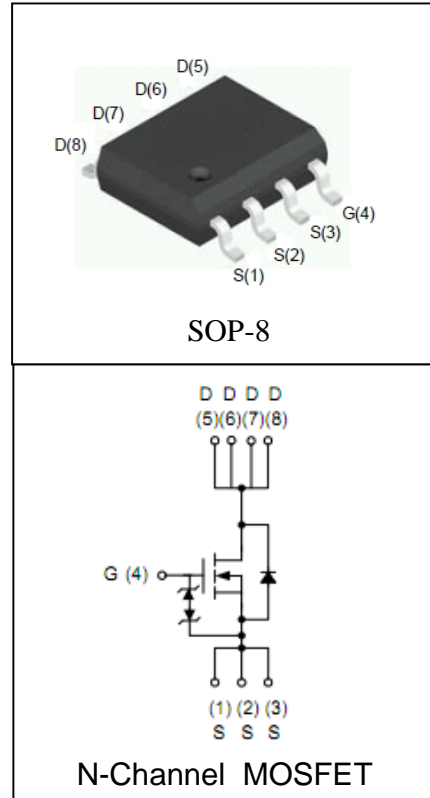

Symbol	Parameter	Rating	Unit
Common Ratings ($T_A = 25^\circ C$ Unless Otherwise Noted)			
V_{DSS}	Drain-Source Voltage	60	V
V_{GSS}	Gate-Source Voltage	± 20	
T_J	Maximum Junction Temperature	150	$^\circ C$
T_{STG}	Storage Temperature Range	-55 to 150	$^\circ C$
I_S	Diode Continuous Forward Current	$T_A = 25^\circ C$ 3	A
Mounted on Large Heat Sink			
I_{DP}	300 μs Pulse Drain Current Tested	$T_A = 25^\circ C$ 20 ^①	A
I_D	Continuous Drain Current ($V_{GS} = 10V$)	$T_A = 25^\circ C$ 5	A
		$T_A = 70^\circ C$ 3.7	
P_D	Maximum Power Dissipation	$T_A = 25^\circ C$ 2.5	W
		$T_A = 70^\circ C$ 1.6	
$R_{\theta JA}$ ^②	Thermal Resistance-Junction to Ambient	50	$^\circ C/W$

Electrical Characteristics ($T_A=25^\circ\text{C}$ Unless Otherwise Noted)

Symbol	Parameter	Test Condition	RU60E5H			Unit
			Min.	Typ.	Max.	
Static Characteristics						
BV_{DSS}	Drain-Source Breakdown Voltage	$V_{GS}=0V, I_{DS}=250\mu A$	60			V
I_{DSS}	Zero Gate Voltage Drain Current	$V_{DS}=60V, V_{GS}=0V$ $T_J=85^\circ\text{C}$			1 30	μA
$V_{GS(th)}$	Gate Threshold Voltage	$V_{DS}=V_{GS}, I_{DS}=250\mu A$	1.5	2	2.7	V
I_{GSS}	Gate Leakage Current	$V_{GS}=\pm 16V, V_{DS}=0V$			± 10	μA
$R_{DS(on)}^{(3)}$	Drain-Source On-state Resistance	$V_{GS}=10V, I_{DS}=5A$		60	70	$m\Omega$
		$V_{GS}=4.5V, I_{DS}=3.5A$		70	80	$m\Omega$
Diode Characteristics						
$V_{SD}^{(3)}$	Diode Forward Voltage	$I_{SD}=2.5A, V_{GS}=0V$			1.2	V
t_{rr}	Reverse Recovery Time	$I_{SD}=2.5A, dI_{SD}/dt=100A/\mu s$		41		ns
Q_{rr}	Reverse Recovery Charge			71		nC
Dynamic Characteristics ⁽⁴⁾						
R_G	Gate Resistance	$V_{GS}=0V, V_{DS}=0V, F=1\text{MHz}$		0.7		Ω
C_{iss}	Input Capacitance	$V_{GS}=0V,$ $V_{DS}=30V,$ Frequency=1.0MHz		460		pF
C_{oss}	Output Capacitance			44		
C_{rss}	Reverse Transfer Capacitance			24		
$t_{d(ON)}$	Turn-on Delay Time	$V_{DD}=30V, R_L=12\Omega,$ $I_{DS}=2.5A, V_{GEN}=10V,$ $R_G=6\Omega$		3		ns
t_r	Turn-on Rise Time			4		
$t_{d(OFF)}$	Turn-off Delay Time			12		
t_f	Turn-off Fall Time			5		
Gate Charge Characteristics ⁽⁴⁾						
Q_g	Total Gate Charge	$V_{DS}=48V, V_{GS}=10V,$ $I_{DS}=2.5A$		16	21	nC
Q_{gs}	Gate-Source Charge			3		
Q_{gd}	Gate-Drain Charge			5		

- Notes: ① Pulse width limited by safe operating area.
 ② When mounted on 1 inch square copper board, $t \leq 10\text{sec}$.
 ③ Pulse test ; Pulse width $\leq 300\mu s$, duty cycle $\leq 2\%$.
 ④ Guaranteed by design, not subject to production testing.

Typical Characteristics

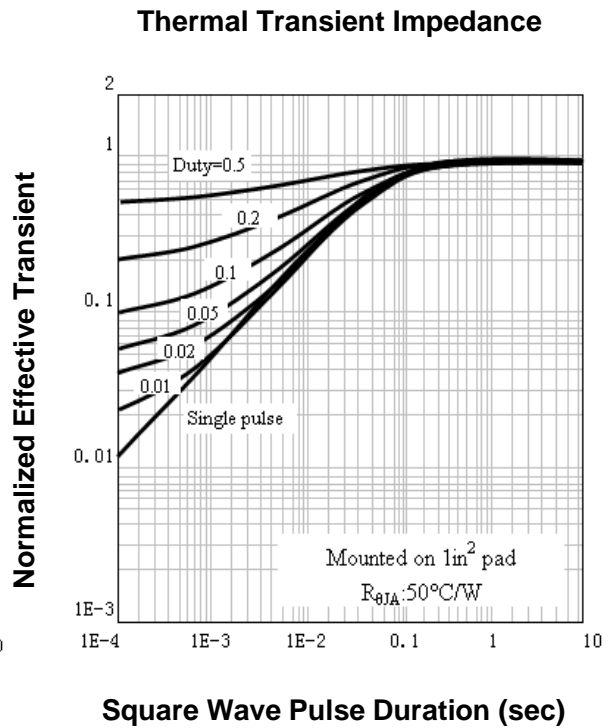
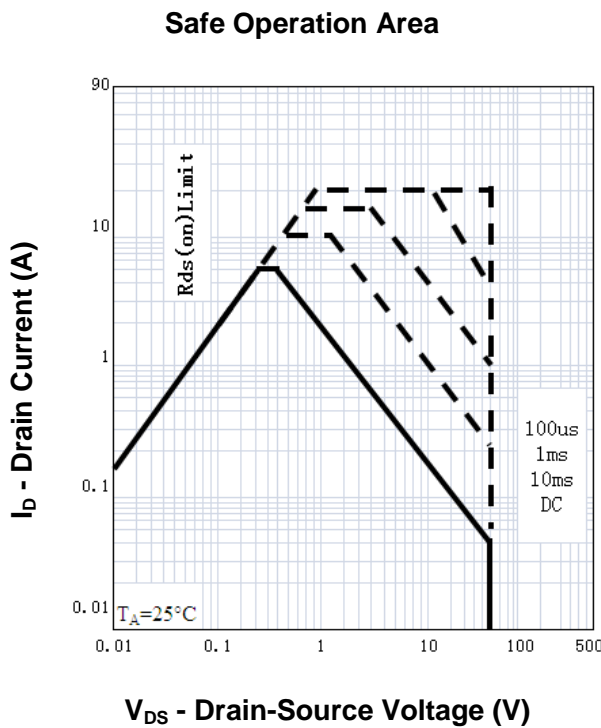
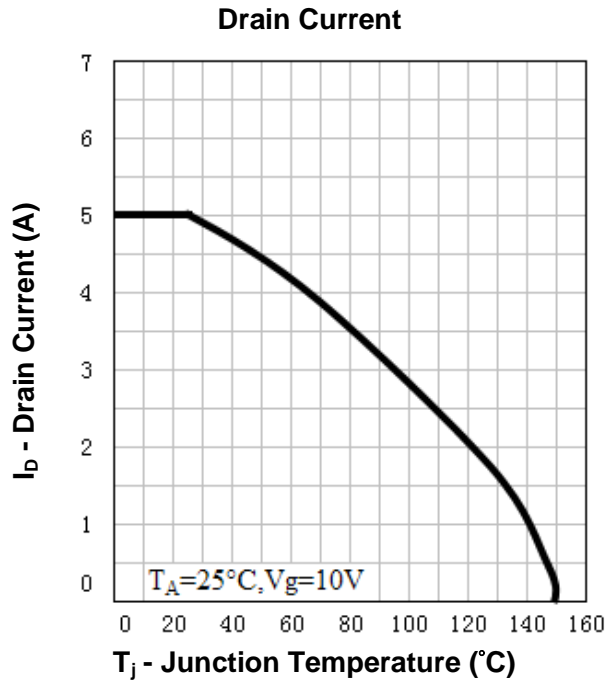
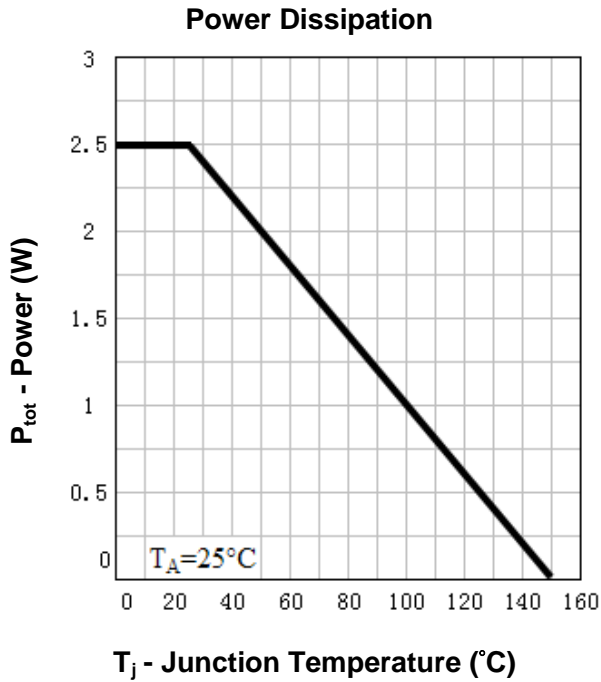

Typical Characteristics

Output Characteristics

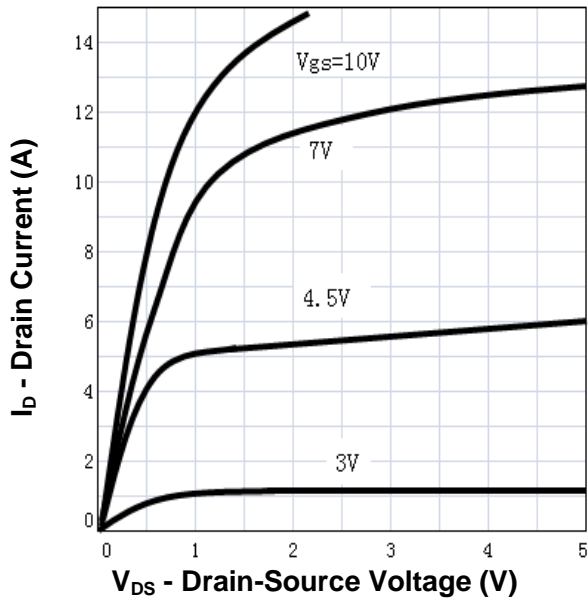

Drain-Source On Resistance

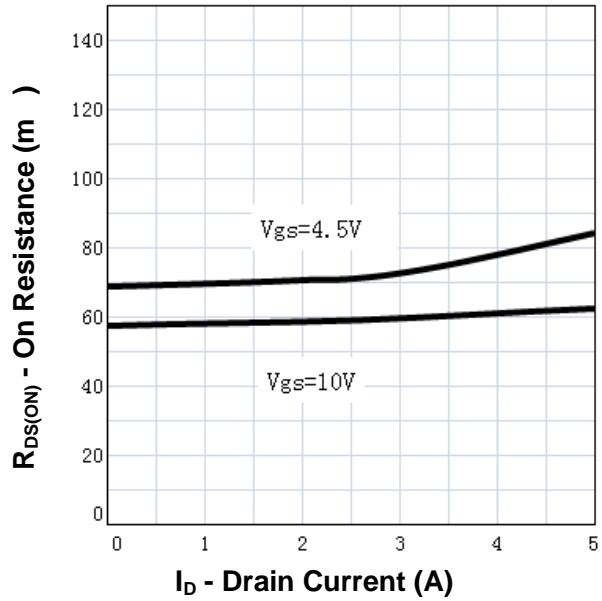

Drain-Source On Resistance

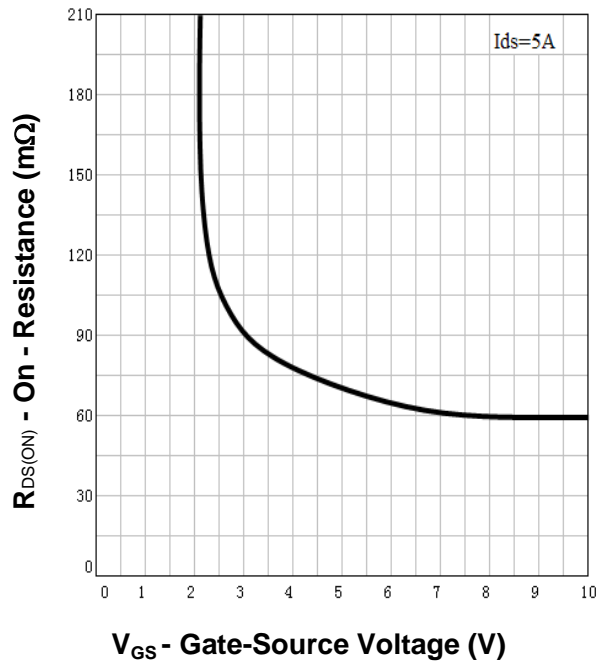

Gate Threshold Voltage

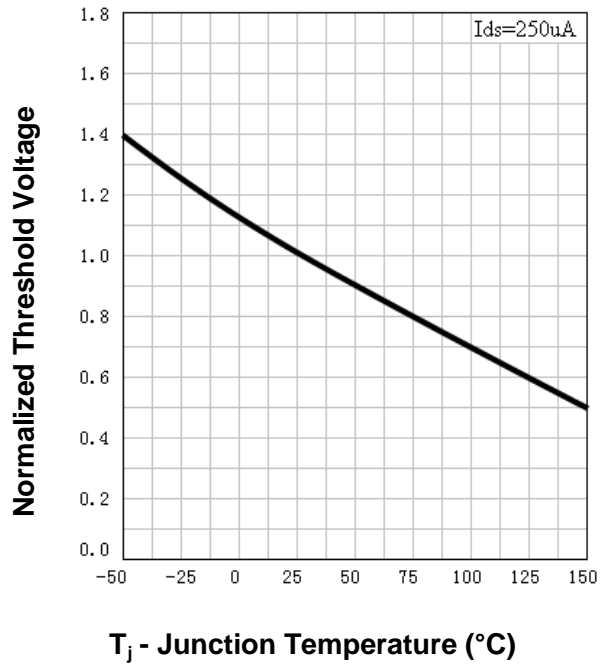

Typical Characteristics

Drain-Source On Resistance

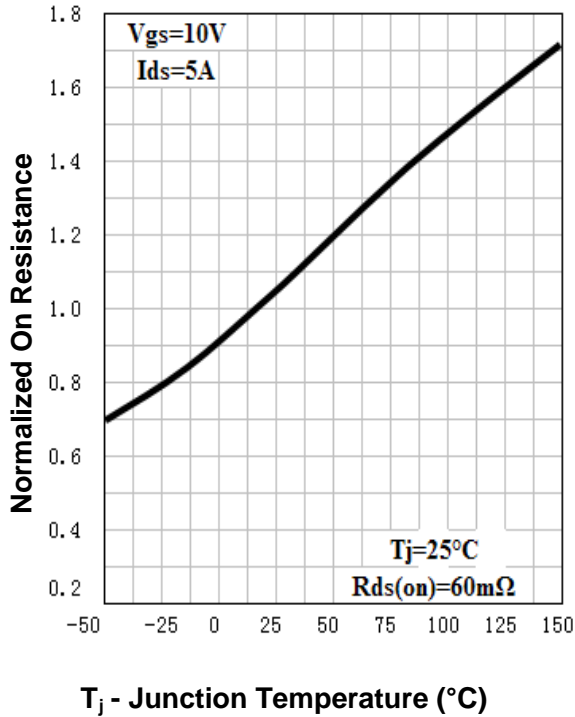

Source-Drain Diode Forward

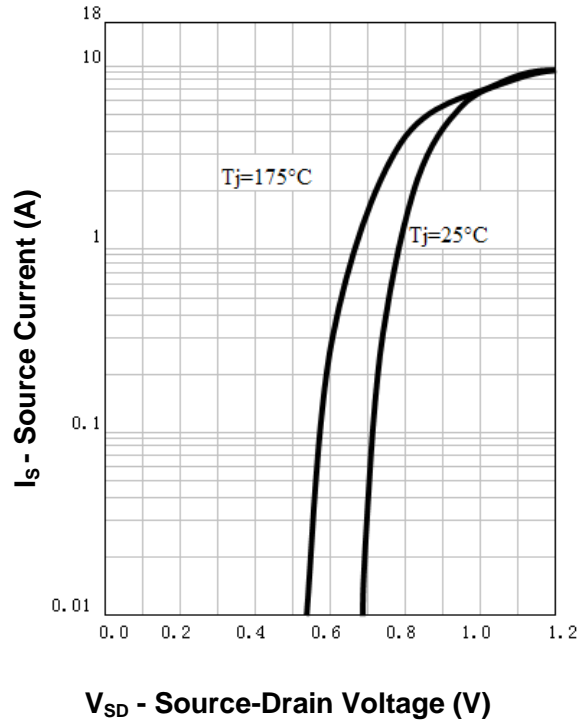

Capacitance

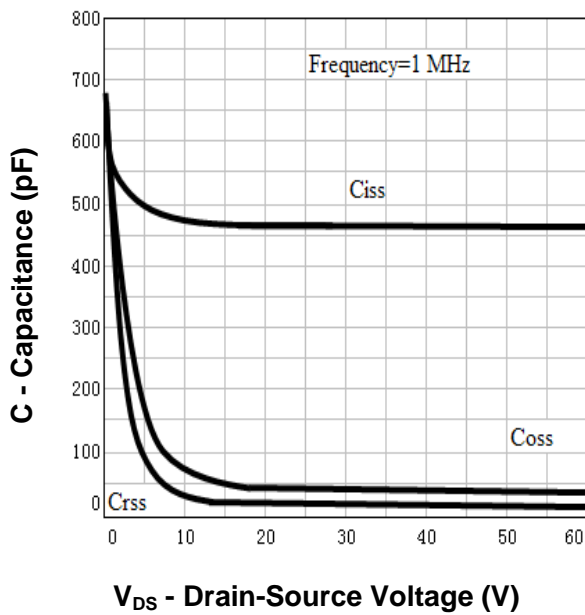

Gate Charge

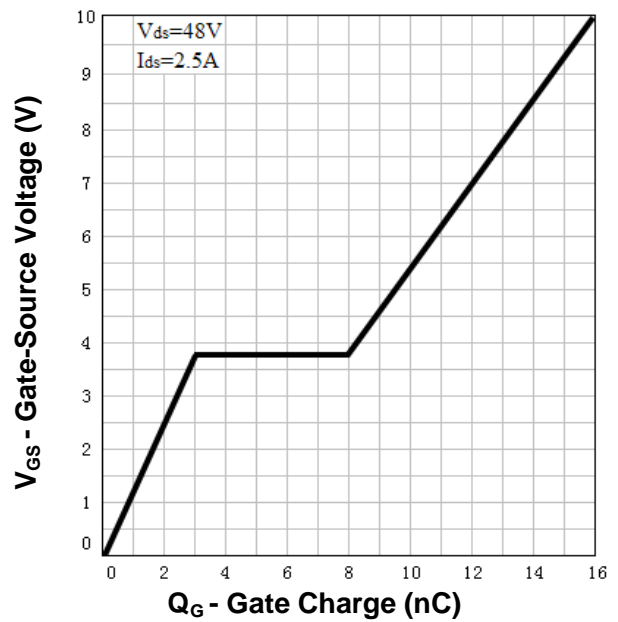

Avalanche Test Circuit and Waveforms

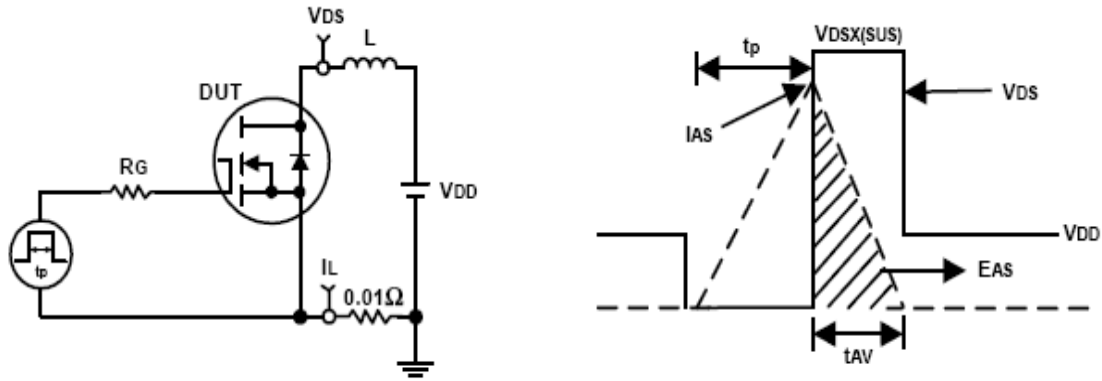

Switching Time Test Circuit and Waveforms

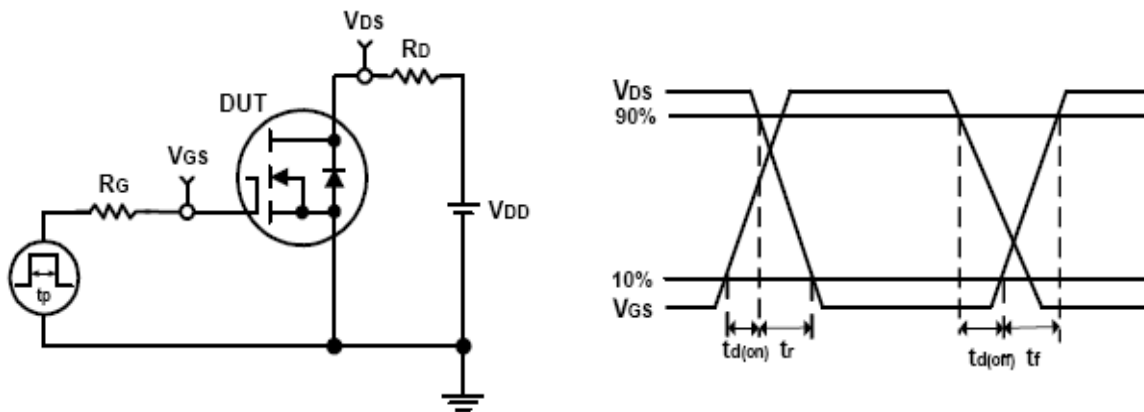

Ordering and Marking Information

Device	Marking	Package	Packaging	Quantity	Reel Size	Tape width
RU60E5H	RU60E5H	SOP-8	Tape&Reel	2500	13''	12mm

Package Information

SOP-8

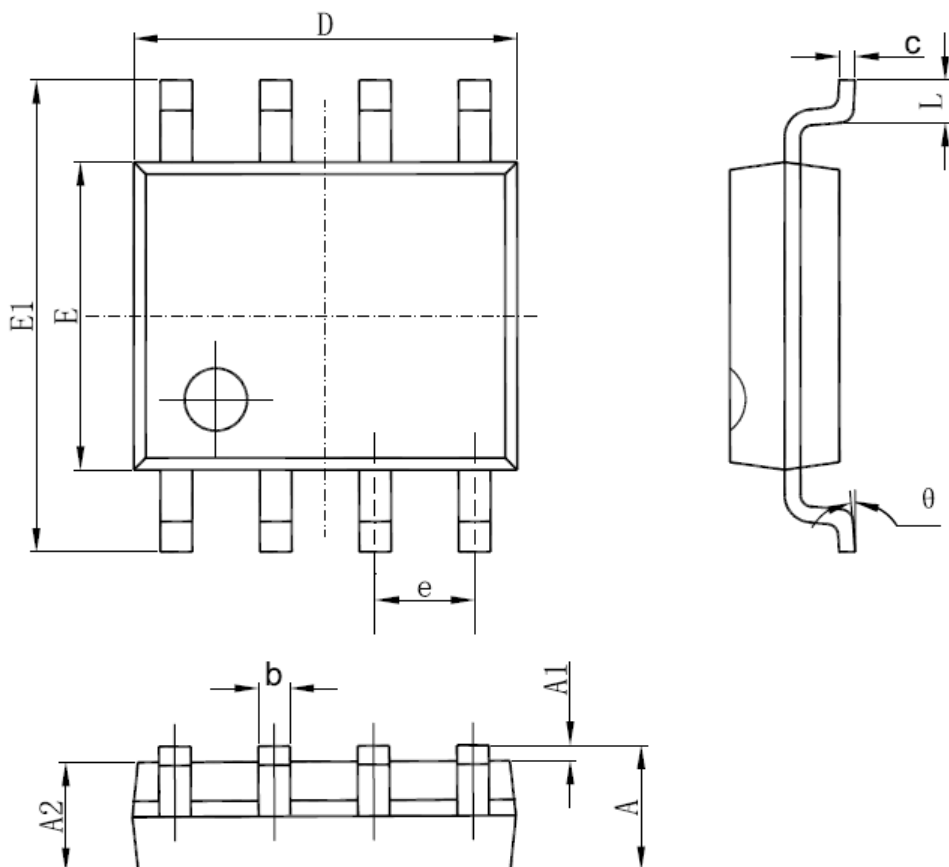

SYMBOL	MM		INCH		SYMBOL	MM		INCH	
	MIN	MAX	MIN	MAX		MIN	MAX	MIN	MAX
A	1.350	1.750	0.053	0.069	E	3.800	4.000	0.150	0.157
A1	0.100	0.250	0.004	0.010	E1	5.800	6.200	0.228	0.244
A2	1.350	1.550	0.053	0.061	e	1.270 (BSC)		0.050 (BSC)	
b	0.330	0.510	0.013	0.020	L	0.400	1.270	0.016	0.050
c	0.170	0.250	0.006	0.010	θ	0°	8°	0°	8°
D	4.700	5.100	0.185	0.200					

ALL DIMENSIONS REFER TO JEDEC STANDARD
DO NOT INCLUDE MOLD FLASH OR PROTRUSIONS

Customer Service

Worldwide Sales and Service:

Sales@ruichips.com

Technical Support:

Technical@ruichips.com

Investor Relations Contacts:

Investor@ruichips.com

Marcom Contact:

Marcom@ruichips.com

Editorial Contact:

Editorial@ruichips.com

HR Contact:

HR@ruichips.com

Legal Contact:

Legal@ruichips.com

Shen Zhen RUICHIPS Semiconductor CO., LTD

Room 501, the 5floor An Tong Industrial Building,
NO.207 Mei Hua Road Fu Tian Area Shen Zhen City, CHINA

TEL: (86-755) 8311-5334

FAX: (86-755) 8311-4278

E-mail: Sales-SZ@ruichips.com