

# KSB13003C



# KSB13003C

## High Voltage Switch Mode Application

- High voltage, High speed power switching
- Suitable for Electronic Ballast up to 21W

1.5 Amperes  
NPN Silicon Power Transistor  
1.1 Watts

## Absolute Maximum Ratings TC=25°C unless otherwise noted

CHARACTERISTICS	SYMBOL	RATING	UNIT
Collector-Base Voltage	$V_{CBO}$	800	V
Collector-Emitter Voltage	$V_{CEO}$	450	V
Emitter-Base Voltage	$V_{EBO}$	9	V
Collector Current(DC)	$I_C$	1.5	A
Collector Current(Pulse)	$I_{CP}$	3	A
Base Current	$I_B$	0.75	A
Collector Dissipation(Tc=25°C)	$P_C$	1.10	W
Junction Temperature	$T_J$	150	°C
Storage Temperature	$T_{STG}$	-55~150	°C

TO-92  
1. Base  
2. Collector  
3. Emitter

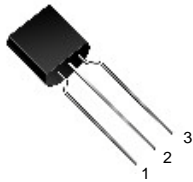

## Electrical Characteristics TC=25°C unless otherwise noted

CHARACTERISTICS	SYMBOL	Test Condition	Min	Typ.	Max	Unit
Collector-Base Breakdown Voltage	$V_{CBO}$	$I_C=500\mu A, I_E=0$	800			V
Collector-Emitter Breakdown Voltage	$V_{CEO}$	$I_C=10mA, I_B=0$	450			V
Emitter Cut-off Current	$I_{EBO}$	$V_{EB}=9.0V, I_C=0$			10	$\mu A$
*DC Current Gain	$h_{FE1}$ $h_{FE2}$	$V_{CE}=10V, I_C=0.4A$ $V_{CE}=10V, I_C=1A$	20 6		40	- -
*Collector-Emitter Saturation Voltage	$V_{CE(sat)}$	$I_C=0.5A, I_B=0.1A$ $I_C=1.5A, I_B=0.5A$			0.5 1.0	V V
*Base-Emitter Saturation Voltage	$V_{BE(sat)}$	$I_C=0.5A, I_B=0.1A$			1.0	V
Output Capacitance	$C_{ob}$	$V_{CB}=10V, f=0.1MHz$		21		pF
Current Gain Bandwidth Product	$f_T$	$V_{CE}=10V, I_C=0.1A$	4			MHz
Turn on Time	$t_{on}$	$V_{CC}=125V, I_C=2A$ $I_{B1}=0.2A, I_{B2}=-0.2A$ $R_L=125\Omega$			1.1	$\mu s$
Storage Time	$t_{stg}$				4.0	$\mu s$
Fall Time	$t_F$				0.7	$\mu s$

\* Pulse Test: Pulse Widths $\leq 300\mu s$ , Duty Cycles $\leq 2\%$

Note.

<b>hFE1 Classification</b>	R	20 ~ 30
	O	25 ~ 35
	Y	30 ~ 40

Package Mark information.

<b>S CR 13003 YWW Z</b>	S	SemiHow Symbol
	YWW	Y; year code, WW; week code
	Z	hFE1 Classification

# Typical Characteristics

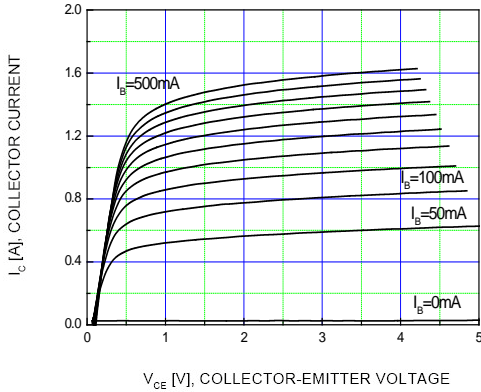

Figure 1. Static Characteristic

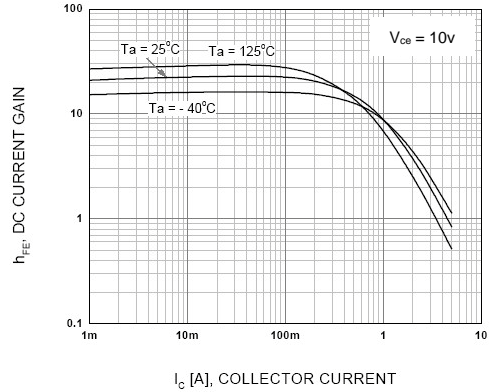

Figure 2. DC current Gain

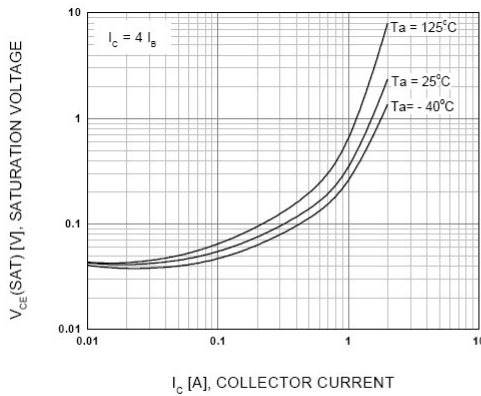

Figure 3. Collector-Emitter Saturation Voltage

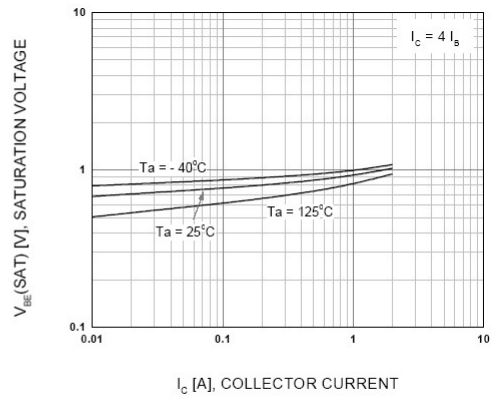

Figure 4. Base-Emitter Saturation Voltage

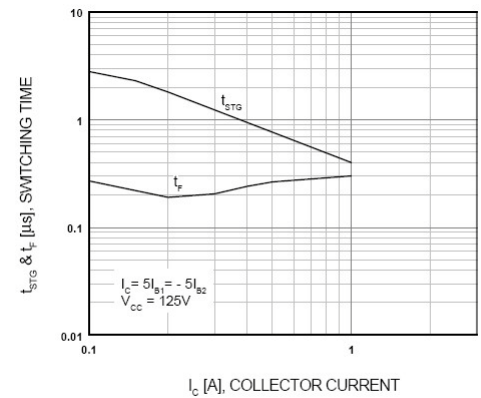

Figure 5. Resistive Load Switching Time

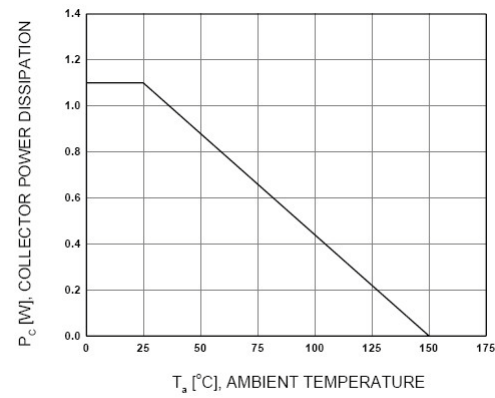

Figure 6. Power Derating

## Typical Characteristics

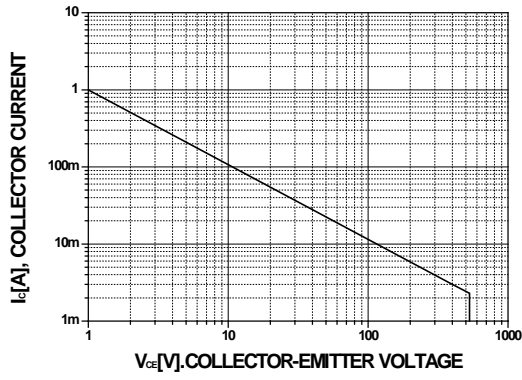

Figure 7. Forward Bias Safe Operating Area

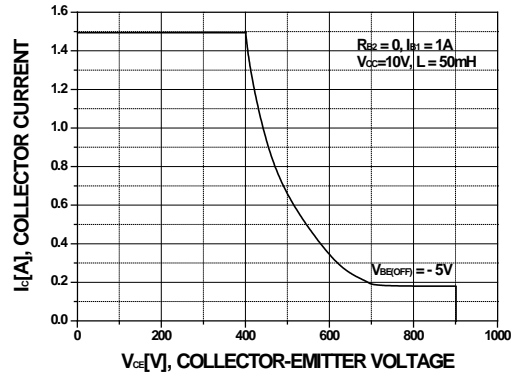
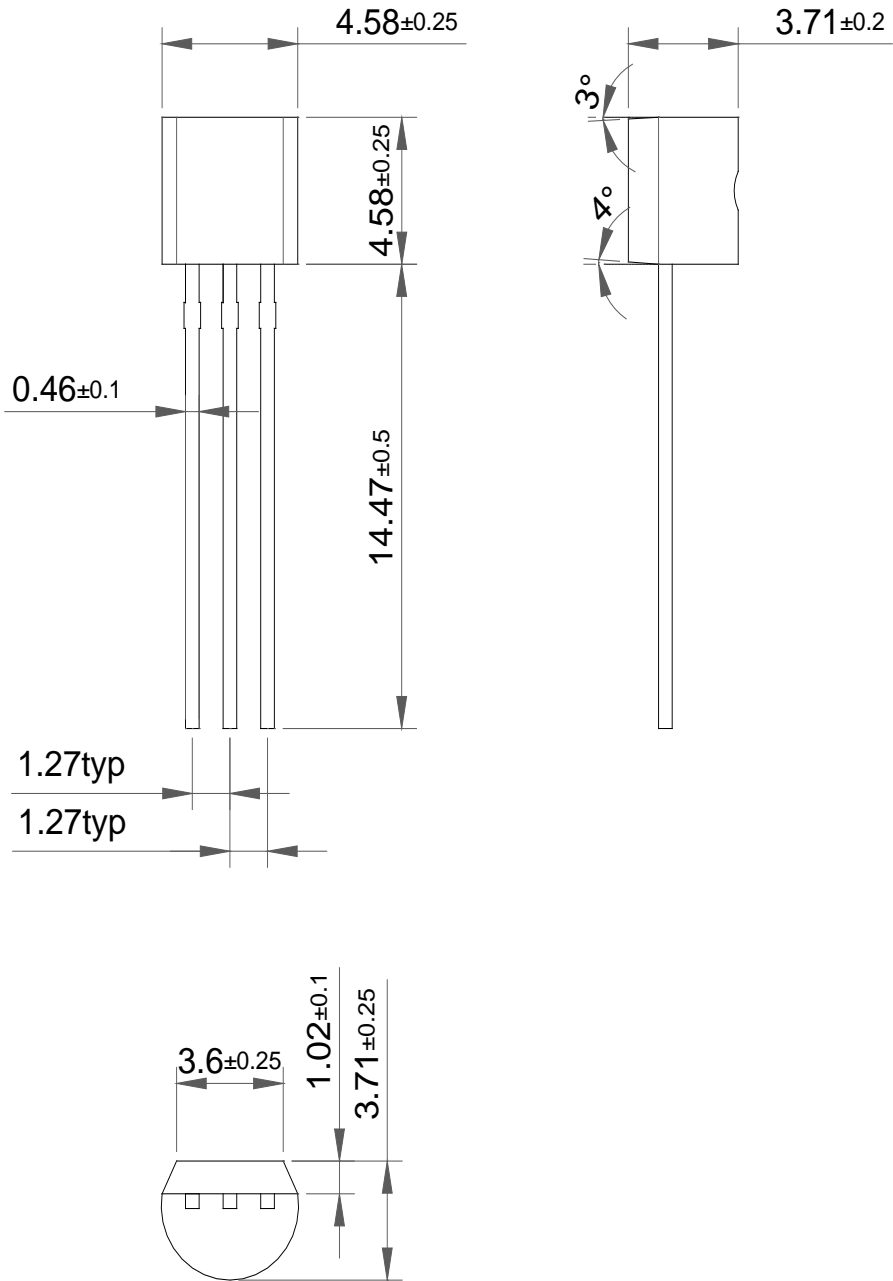

Figure 8. Reverse Bias Safe Operating Area

Package Dimension

TO-92



Dimensions in Millimeters

## Package Dimension

## TO-92 TAPING

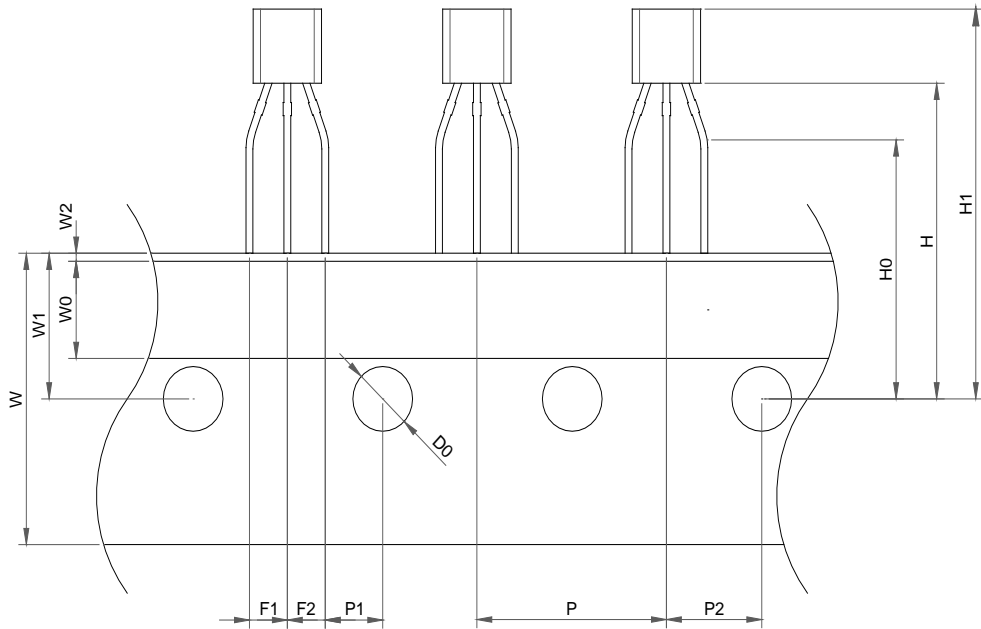

Item	Symbol	Dimension [mm]	
		Reference	Tolerance
Component pitch	P	12.7	±0.5
Side lead to center of feed hole	P1	3.85	±0.5
Center lead to center of feed hole	P2	6.35	±0.5
Lead pitch	F1,F2	2.5	+0.2/-0.1
Carrier Tape width	W	18.0	+1.0/-0.5
Adhesive tape width	W0	6.0	±0.5
Tape feed hole location	W1	9.0	±0.5
Adhesive tape position	W2	1.0 MAX	
Center of feed hole to bottom of component	H	19.5	±1
Center of feed hole to lead form	H0	16.0	±0.5
Component height	H1	27.0 max	
Tape feed hole diameter	D0	4.0	±0.2