

KSB13002AR

SemiHow
Know-How for Semiconductor

KSB13002AR

High Voltage Switch Mode Application

- High Voltage, High Speed Switching
- Suitable for Switching regulator, Inverters motor controls
- 150°C Max. Operating temperature
- 8KV ESD proof at HBM (C=100pF, R=1.5kΩ)

Absolute Maximum Ratings TC=25°C unless otherwise noted

0.8 Amperes
NPN Silicon Power Transistor
1.0 Watts

CHARACTERISTICS	SYMBOL	RATING	UNIT
Collector-Base Voltage	V_{CBO}	700	V
Collector-Emitter Voltage	V_{CES}	700	V
Collector-Emitter Voltage	V_{CEO}	400	V
Emitter-Base Voltage	V_{EBO}	9	V
Collector Current	I_C	0.8	A
Collector Dissipation	P_C	1.0	W
Storage Temperature	T_{STG}	-65~150	°C
Max. Operating Junction Temperature	T_J	150	°C

TO-92
1. Emitter
2. Collector
3. Base

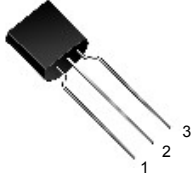

Electrical Characteristics TC=25°C unless otherwise noted

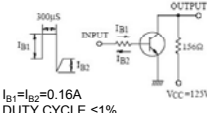
CHARACTERISTICS	SYMBOL	Test Condition	Min	Typ.	Max	Unit
Collector-Base Breakdown Voltage	V_{CBO}	$I_C=500\mu A, I_E=0$	700			V
Collector-Emitter Breakdown Voltage	V_{CEO}	$I_C=1mA, I_B=0$	400			V
Emitter Cut-off Current	I_{EBO}	$V_{EB}=9V, I_C=0$			10	μA
*DC Current Gain	h_{FE1} (note) h_{FE2}	$V_{CE}=10V, I_C=100mA$ $V_{CE}=10V, I_C=280mA$	9 5		38	
*Collector-Emitter Saturation Voltage	$V_{CE(sat)}$	$I_C=50mA, I_B=10mA$ $I_C=100mA, I_B=20mA$			0.45 1.0	V V
*Base-Emitter Saturation Voltage	$V_{BE(sat)}$	$I_C=50mA, I_B=10mA$ $I_C=100mA, I_B=10mA$			0.9 1.1	V V
Output Capacitance	C_{ob}	$V_{CB}=10V, f=0.1MHz$		21		pF
Current Gain Bandwidth Product	f_T	$V_{CE}=10V, I_C=0.1A$	4			MHz
Turn on Time	t_{on}	 <p>$I_{B1}=I_{B2}=0.16A$ DUTY CYCLE $\leq 1\%$</p>		0.5	μs	
Storage Time	t_{stg}				4.0	μs
Fall Time	t_f				0.7	μs

* Pulse Test: Pulse Width $\leq 300\mu s$, Duty Cycle $\leq 2\%$

Note.

hFE1 Classification	R	15 ~ 25
	O	20 ~ 30
	Y	25 ~ 35

Package Mark information.

S AR 13002 YWW Z	R	Pin connection (ECB)
	YWW	Y; year code, WW; week code
	Z	hFE1 Classification

Typical Characteristics

DC CURRENT GAIN

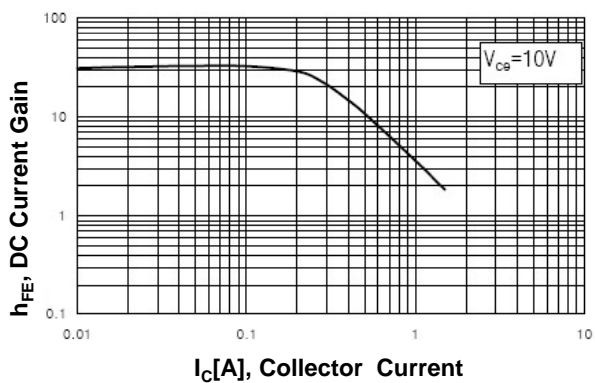

Safety Operating Area

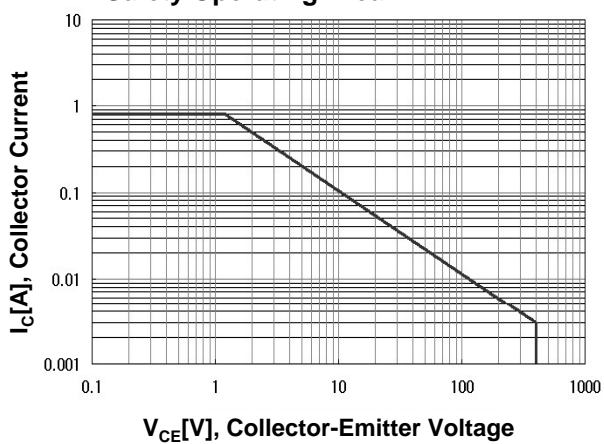

Power Derating

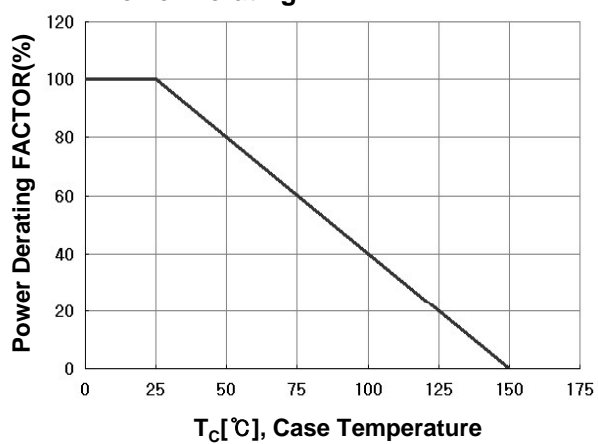

Package Dimension

TO-92

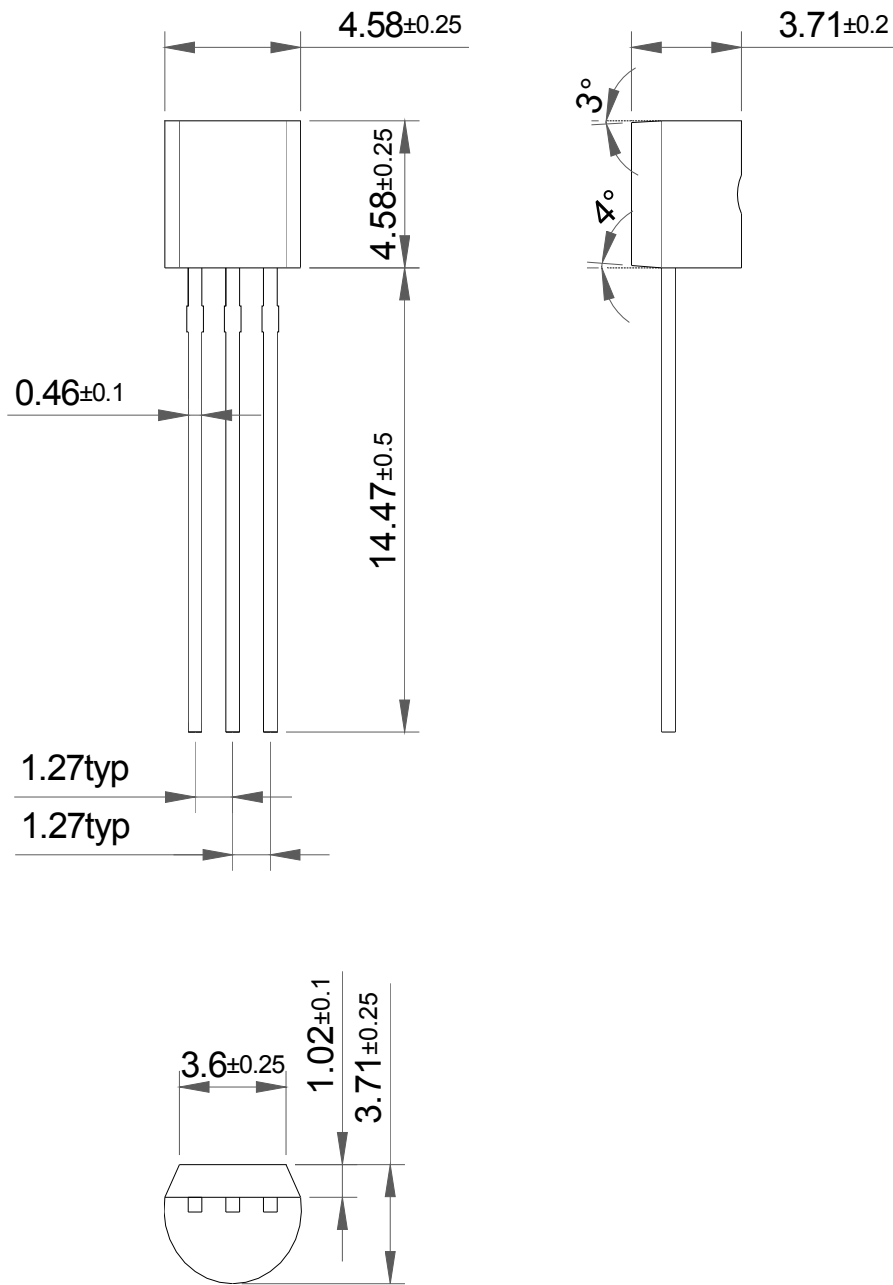

Dimensions in Millimeters

Package Dimension

TO-92 TAPING

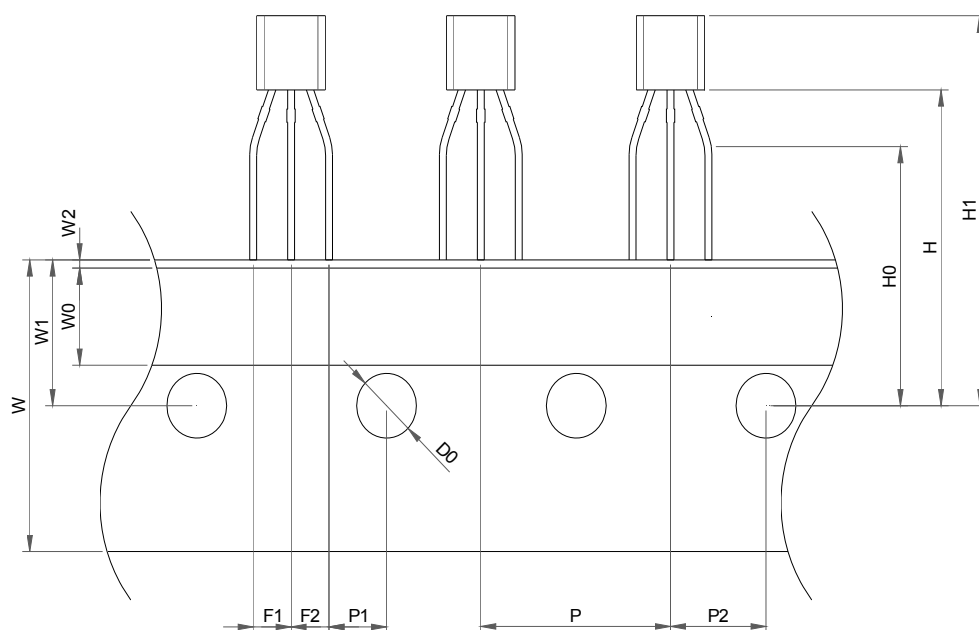

Item	Symbol	Dimension [mm]	
		Reference	Tolerance
Component pitch	P	12.7	±0.5
Side lead to center of feed hole	P1	3.85	±0.5
Center lead to center of feed hole	P2	6.35	±0.5
Lead pitch	F1,F2	2.5	+0.2/-0.1
Carrier Tape width	W	18.0	+1.0/-0.5
Adhesive tape width	W0	6.0	±0.5
Tape feed hole location	W1	9.0	±0.5
Adhesive tape position	W2	1.0 MAX	
Center of feed hole to bottom of component	H	19.5	±1
Center of feed hole to lead form	H0	16.0	±0.5
Component height	H1	27.0 max	
Tape feed hole diameter	D0	4.0	±0.2