

Zener Voltage Regulators

200 mW SOD-323 Surface Mount

- RoHS product for packing code suffix "G"
Halogen free product for packing code suffix "H"
- Weight:0.004g

ORDERING INFORMATION

Device*	Package	Shipping
MM3ZxxT1	SOD-323	3000/Tape&Reel

This series of Zener diodes is packaged in a SOD-323 surface mount package that has a power dissipation of 200 mW. They are designed to provide voltage regulation protection and are especially attractive in situations where space is at a premium. They are well suited for applications such as cellular phones, hand held portables, and high density PC boards.

Specification Features:

- Standard Zener Breakdown Voltage Range – 2.4 V to 75 V
- Steady State Power Rating of 200 mW
- Small Body Outline Dimensions: 0.067" x 0.049"(1.7 mm x 1.25 mm)
- Low Body Height: 0.035" (0.9 mm)
- Package Weight: 4.507 mg/unit
- ESD Contact Model Test Pulse: 6KV,1/30ns (waveform)
- Pb-Free package is available.

Mechanical Characteristics:

CASE: Void-free, transfer-molded plastic

FINISH: All external surfaces are corrosion resistant

MAXIMUM CASE TEMPERATURE FOR SOLDERING PURPOSES:

260°C for 10 Seconds

POLARITY: Cathode indicated by polarity band

FLAMMABILITY RATING: UL94 V-0

MOUNTING POSITION: Any

MAXIMUM RATINGS

Rating	Symbol	Max	Unit
Total Device Dissipation FR-5 Board, (Note 1.) @ TA = 25°C Derate above 25°C	P _D	200	mW
Thermal Resistance from Junction to Ambient	R _{θJA}	635	°C/W
Junction and Storage Temperature Range	T _J , T _{stg}	-65 to+150	°C

1. FR-4 Minimum Pad

MM3Z2V4T1 SERIES



SOD-323

MARKING DIAGRAM

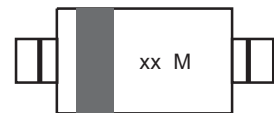

xx = Specific Device Code
M = Date Code



ELECTRICAL CHARACTERISTICS

($T_A = 25^\circ\text{C}$ unless otherwise noted,
 $V_F = 0.9\text{ V Max. @ } I_F = 10\text{ mA}$ for all types)

Symbol	Parameter
V_Z	Reverse Zener Voltage @ I_{ZT}
I_{ZT}	Reverse Current
Z_{ZT}	Maximum Zener Impedance @ I_{ZT}
I_{ZK}	Reverse Current
Z_{ZK}	Maximum Zener Impedance @ I_{ZK}
I_R	Reverse Leakage Current @ V_R
V_R	Reverse Voltage
I_F	Forward Current
V_F	Forward Voltage @ I_F
ΘV_Z	Maximum Temperature Coefficient of V_Z
C	Max. Capacitance @ $V_R = 0$ and $f = 1\text{ MHz}$

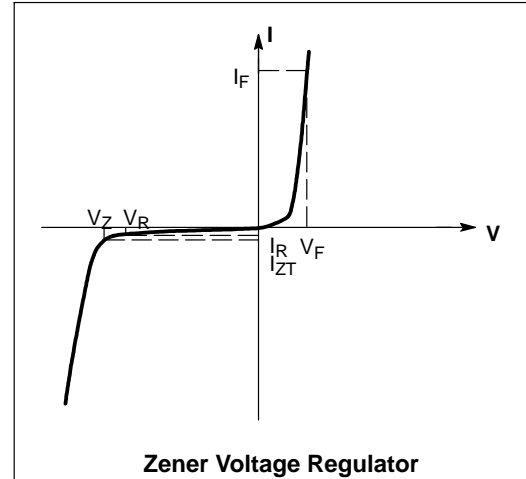

MM3Z2V4T1 SERIES

ELECTRICAL CHARACTERISTICS ($T_A = 25^\circ\text{C}$ unless otherwise noted, $V_F = 0.9\text{ V Max.}$ @ $I_F = 10\text{ mA}$ for all types)

Device	Device Marking	Zener Voltage (Note 2.)			Zener Impedance			Leakage Current		θV_Z (mV/k) @ I_Z		C @ $V_R = 0$ f = 1 MHz	
		V_Z (Volts)			Z_{ZT} @ I_{ZT}	Z_{ZK} @ I_{ZK}		I_R @ V_R		Min	Max		
		Min	Nom	Max	mA	Ω	Ω	mA	μA	Volts	Min	Max	pF
MM3Z2V4T1	00	2.2	2.4	2.6	5	100	1000	0.5	50	1.0	-3.5	0	450
MM3Z2V7T1	01	2.5	2.7	2.9	5	100	1000	0.5	20	1.0	-3.5	0	450
MM3Z3V0T1	02	2.8	3.0	3.2	5	100	1000	0.5	10	1.0	-3.5	0	450
MM3Z3V3T1	05	3.1	3.3	3.5	5	95	1000	0.5	5	1.0	-3.5	0	450
MM3Z3V6T1	06	3.4	3.6	3.8	5	90	1000	0.5	5	1.0	-3.5	0	450
MM3Z3V9T1	07	3.7	3.9	4.1	5	90	1000	0.5	3	1.0	-3.5	-2.5	450
MM3Z4V3T1	08	4.0	4.3	4.6	5	90	1000	0.5	3	1.0	-3.5	0	450
MM3Z4V7T1	09	4.4	4.7	5.0	5	80	800	0.5	3	2.0	-3.5	0.2	260
MM3Z5V1T1	0A	4.8	5.1	5.4	5	60	800	0.5	2	2.0	-2.7	1.2	225
MM3Z5V6T1	0C	5.2	5.6	6.0	5	40	700	0.5	1	2.0	-2.0	2.5	200
MM3Z6V2T1	0E	5.8	6.2	6.6	5	10	100	0.5	3	4.0	0.4	3.7	185
MM3Z6V8T1	0F	6.4	6.8	7.2	5	15	160	0.5	2	4.0	1.2	4.5	155
MM3Z7V5T1	0G	7.0	7.5	7.9	5	15	160	0.5	1	5.0	2.5	5.3	140
MM3Z8V2T1	0H	7.7	8.2	8.7	5	15	160	0.5	0.7	5.0	3.2	6.2	135
MM3Z9V1T1	0K	8.5	9.1	9.6	5	15	160	0.5	0.2	7.0	3.8	7.0	130
MM3Z10VT1	0L	9.4	10	10.6	5	20	160	0.5	0.1	8.0	4.5	8.0	130
MM3Z11VT1	0M	10.4	11	11.6	5	20	160	0.5	0.1	8.0	5.4	9.0	130
MM3Z12VT1	0N	11.4	12	12.7	5	25	80	0.5	0.1	8.0	6.0	10	130
MM3Z13VT1	0P	12.4	13.25	14.1	5	30	80	0.5	0.1	8.0	7.0	11	120
MM3Z15VT1	0T	14.3	15	15.8	5	30	400	0.5	0.05	10.5	9.2	13	110
MM3Z16VT1	0U	15.3	16.2	17.1	5	40	400	0.5	0.05	11.2	10.4	14	105
MM3Z18VT1	0W	16.8	18	19.1	5	45	400	0.5	0.05	12.6	12.4	16	100
MM3Z20VT1	0Z	18.8	20	21.2	5	55	500	0.5	0.05	14.0	14.4	18	85
MM3Z22VT1	10	20.8	22	23.3	5	55	500	0.5	0.05	15.4	16.4	20	85
MM3Z24VT1	11	22.8	24.2	25.6	5	70	120	0.5	0.05	16.8	18.4	22	80
MM3Z27VT1	12	25.1	27	28.9	2	80	300	0.5	0.05	18.9	21.4	25.3	70
MM3Z30VT1	14	28	30	32	2	80	300	0.5	0.05	21.0	24.4	29.4	70
MM3Z33VT1	18	31	33	35	2	80	300	0.5	0.05	23.2	27.4	33.4	70
MM3Z36VT1	19	34	36	38	2	90	500	0.5	0.05	25.2	30.4	37.4	70
MM3Z39VT1	20	37	39	41	2	130	500	0.5	0.05	27.3	33.4	41.2	45
MM3Z43VT1	21	40	43	46	2	150	500	0.5	0.05	30.1	37.6	46.6	40
MM3Z47VT1	1A	44	47	50	2	170	500	0.5	0.05	32.9	42.0	51.8	40
MM3Z51VT1	1C	48	51	54	2	180	500	0.5	0.05	35.7	46.6	57.2	40
MM3Z56VT1	1D	52	56	60	2	200	500	0.5	0.05	39.2	52.2	63.8	40
MM3Z62VT1	1E	58	62	66	2	215	500	0.5	0.05	43.4	58.8	71.6	35
MM3Z68VT1	1F	64	68	72	2	240	500	0.5	0.05	47.6	65.6	79.8	35
MM3Z75VT1	1G	70	75	79	2	255	500	0.5	0.05	52.5	73.4	88.6	35

2. Zener voltage is measured with a pulse test current I_Z at an ambient temperature of 25°C .

Typical Characteristics

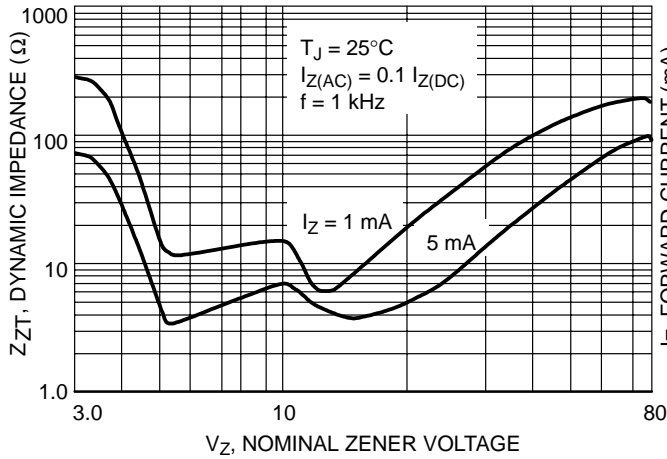

Figure 1. Effect of Zener Voltage on Zener Impedance

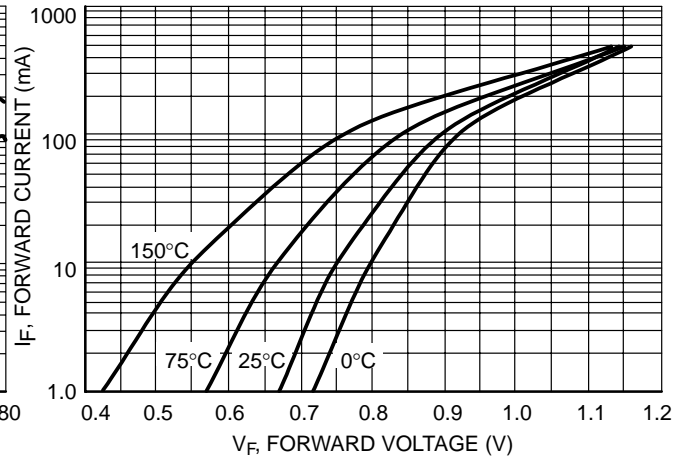

Figure 2. Typical Forward Voltage

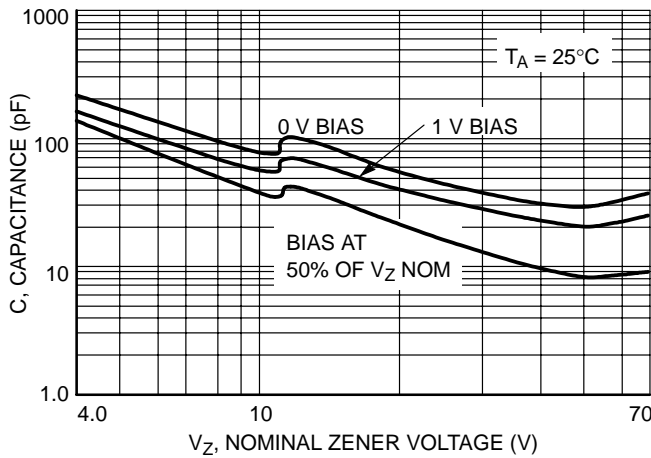

Figure 3. Typical Capacitance

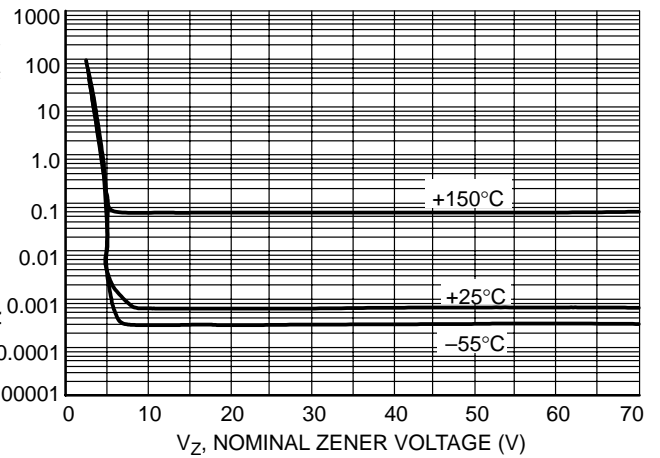

Figure 4. Typical Leakage Current

Typical Characteristics

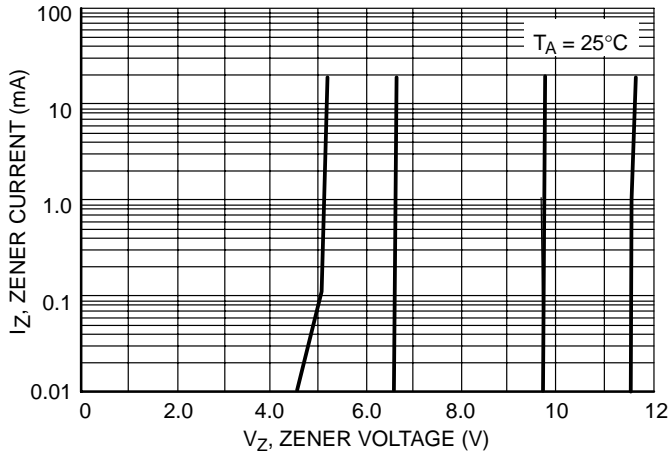

Figure 5. Zener Voltage versus Zener Current (V_Z Up to 12 V)

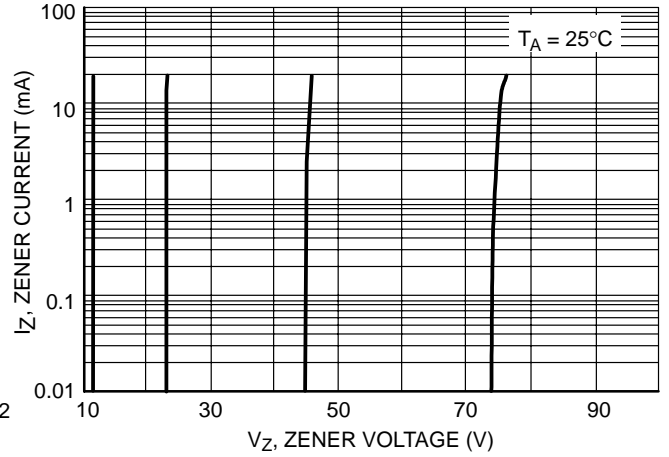

Figure 6. Zener Voltage versus Zener Current (12 V to 75 V)

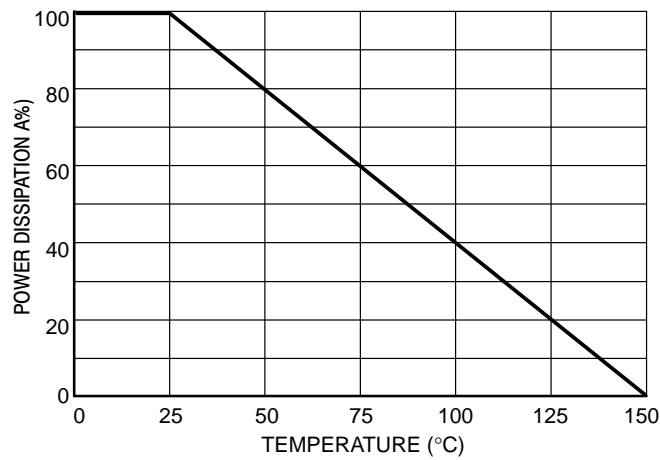
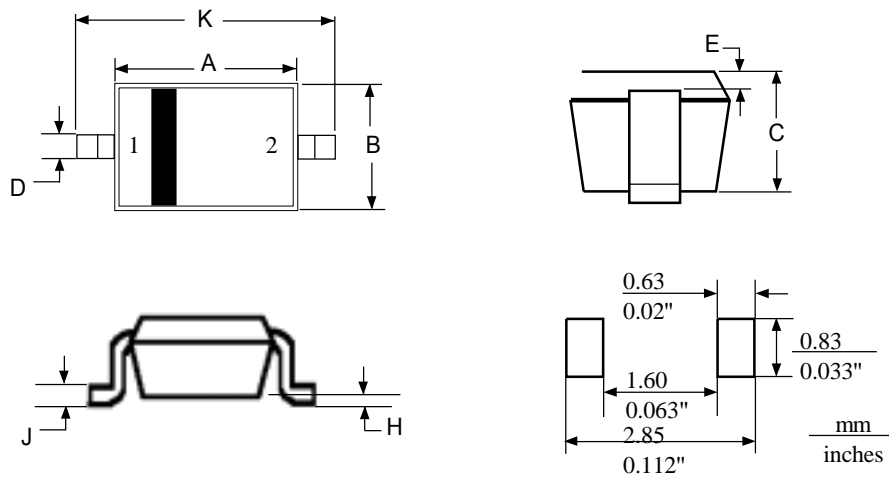

Figure 7. Steady State Power Derating

MM3Z2V4T1 SERIES

PACKAGE DIMENSIONS SOD-323



NOTES:

1. CONTROLLING DIMENSION: MILLIMETERS
2. LEAD THICKNESS SPECIFIED PER L/F DRAWING WITH SOLDER PLATING.

DIN	MILLIMETERS		INCHES	
	MIN	MAX	MIN	MAX
A	1.60	1.80	0.063	0.071
B	1.15	1.35	0.045	0.053
C	0.80	1.00	0.031	0.039
D	0.25	0.40	0.010	0.016
E	0.15 REF		0.006 REF	
H	0.00	0.10	0.0000	0.004
J	0.089	0.177	0.0035	0.0070
K	2.30	2.70	0.091	0.106

STYLE 1:
PIN 1: CATHODE
2: ANODE