



## ZenerVoltage Regulators

### 100 mW SOD-523 Surface Mount

**MM5ZLLL T1**  
**SERIES**

#### ORDERING INFORMATION

Device	Package	Shipping
MM5ZxxxT1	SOD-523	3000/Tape&Reel

This series of Zener diodes is packaged in a SOD-523 surface mount package that has a power dissipation of 100 mW. They are designed to provide voltage regulation protection and are especially attractive in situations where space is at a premium. They are well suited for applications such as cellular phones, hand held portables, and high density PC boards.

#### Specification Features:

- Standard Zener Breakdown Voltage Range – 2.4 V to 75 V
- Steady State Power Rating of 200 mW
- Small Body Outline Dimensions: 0.047" x 0.032"(1.20 mm x 0.80 mm)
- Low Body Height: 0.028" (0.7 mm)
- ESD Rating of Class 3 (>16 kV) per Human Body Model
- Weight:0.0017 g
- RoHS product for packing code suffix "G"
- Halogen free product for packing code suffix "H"

#### Mechanical Characteristics:

**CASE:** Void-free, transfer-molded,thermosetting plastic  
Epoxy Meets UL 94 V-0

**LEAD FINISH:** 100% Matte Sn (Tin)

**QUALIFIED MAX REFLOW TEMPERATURE:**260°C

Device Meets MSL 1 Requirements

**MOUNTING POSITION:** Any

#### MAXIMUM RATINGS

Rating	Symbol	Max	Unit
Total Device Dissipation FR-5 Board, @ T <sub>A</sub> = 25°C	P <sub>D</sub>	100	mW
Junction and Storage Temperature Range	T <sub>J</sub> , T <sub>stg</sub>	-65 to +150	°C

Maximum ratings are those values beyond which device damage can occur. Maximum ratings applied to the device are individual stress limit values (not normal operating conditions) and are not valid simultaneously. If these limits are exceeded, device functional operation is not implied, damage may occur and reliability may be affected.

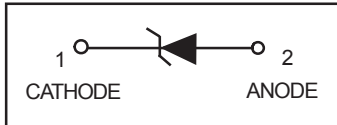
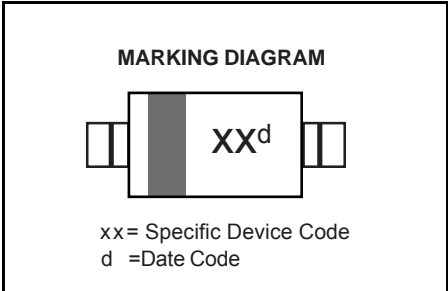

## MM5ZLLLT1 SERIES

### ELECTRICAL CHARACTERISTICS

( $T_A = 25^\circ\text{C}$  unless otherwise noted,  
 $V_F = 0.9\text{ V Max. @ } I_F = 10\text{ mA}$  for all types)

Symbol	Parameter
$V_Z$	Reverse Zener Voltage @ $I_{ZT}$
$I_{ZT}$	Reverse Current
$Z_{ZT}$	Maximum Zener Impedance @ $I_{ZT}$
$I_{ZK}$	Reverse Current
$Z_{ZK}$	Maximum Zener Impedance @ $I_{ZK}$
$I_R$	Reverse Leakage Current @ $V_R$
$V_R$	Reverse Voltage
$I_F$	Forward Current
$V_F$	Forward Voltage @ $I_F$
$\Theta_{VZ}$	Maximum Temperature Coefficient of $V_Z$
C	Max. Capacitance @ $V_R = 0$ and $f = 1\text{ MHz}$

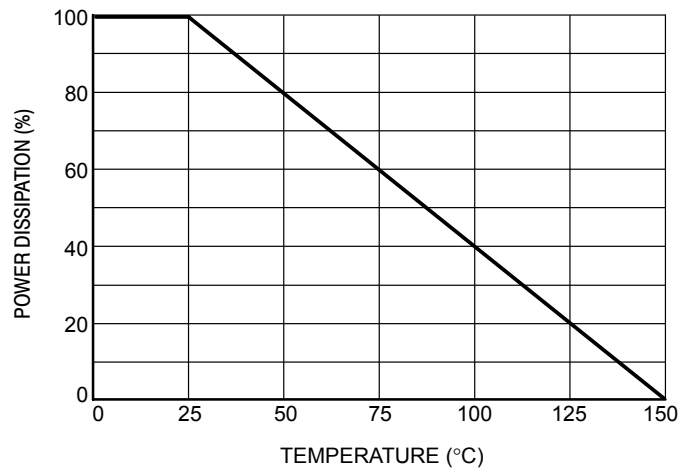
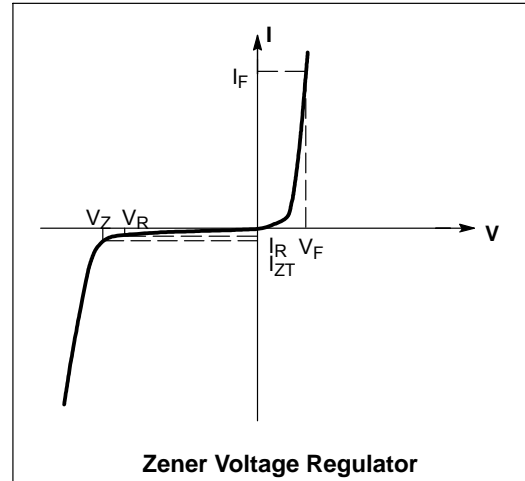

Figure 1. Steady State Power Derating

## MM5ZLLLT1 SERIES

### ELECTRICAL CHARACTERISTICS ( $T_A = 25^\circ\text{C}$ unless otherwise noted, $V_F = 0.9\text{ V Max.}$ @ $I_F = 10\text{ mA}$ for all types)

Device	Device Marking	Zener Voltage (Note 1)				Zener Impedance			Leakage Current		$\theta_{Vz}$ (mV/k) @ $I_{zT}$		C @ $V_R = 0$ f = 1 MHz
		$V_Z$ (Volts)			@ $I_{zT}$	$Z_{zT}$ @ $I_{zT}$	$Z_{zK}$ @ $I_{zK}$		$I_R$ @ $V_R$		Min	Max	
		Min	Nom	Max	mA	$\Omega$	$\Omega$	mA	$\mu\text{A}$	Volts	Min	Max	pF
MM5Z2V4T1	00	2.2	2.4	2.6	5	100	1000	1.0	50	1.0	-3.5	0	450
MM5Z2V7T1	01	2.5	2.7	2.9	5	100	1000	1.0	20	1.0	-3.5	0	450
MM5Z3V0T1	02	2.8	3.0	3.2	5	100	1000	1.0	10	1.0	-3.5	0	450
MM5Z3V3T1	05	3.1	3.3	3.5	5	95	1000	1.0	5	1.0	-3.5	0	450
MM5Z3V6T1	06	3.4	3.6	3.8	5	90	1000	1.0	5	1.0	-3.5	0	450
MM5Z3V9T1	07	3.7	3.9	4.1	5	90	1000	1.0	3	1.0	-3.5	-2.5	450
MM5Z4V3T1	08	4.0	4.3	4.6	5	90	1000	1.0	3	1.0	-3.5	0	450
MM5Z4V7T1	09	4.4	4.7	5.0	5	80	800	1.0	3	2.0	-3.5	0.2	260
MM5Z5V1T1	0A	4.8	5.1	5.4	5	60	500	1.0	2	2.0	-2.7	1.2	225
MM5Z5V6T1	0C	5.2	5.6	6.0	5	40	400	1.0	1	2.0	-2.0	2.5	200
MM5Z6V2T1	0E	5.8	6.2	6.6	5	10	100	1.0	3	4.0	0.4	3.7	185
MM5Z6V8T1	0F	6.4	6.8	7.2	5	15	160	1.0	2	4.0	1.2	4.5	155
MM5Z7V5T1	0G	7.0	7.5	7.9	5	15	160	1.0	1	5.0	2.5	5.3	140
MM5Z8V2T1	0H	7.7	8.2	8.7	5	15	160	1.0	0.7	5.0	3.2	6.2	135
MM5Z9V1T1	0K	8.5	9.1	9.6	5	15	160	1.0	0.2	7.0	3.8	7.0	130
MM5Z10VT1	0L	9.4	10	10.6	5	20	160	1.0	0.1	8.0	4.5	8.0	130
MM5Z11VT1	0M	10.4	11	11.6	5	20	160	1.0	0.1	8.0	5.4	9.0	130
MM5Z12VT1	0N	11.4	12	12.7	5	25	80	1.0	0.1	8.0	6.0	10	130
MM5Z13VT1	0P	12.4	13.4	14.1	5	30	80	1.0	0.1	8.0	7.0	11	120
MM5Z15VT1	0T	14.3	15	15.8	5	30	200	1.0	0.05	10.5	9.2	13	110
MM5Z16VT1	0U	15.3	16.4	17.1	2	40	200	1.0	0.05	11.2	10.4	14	105
MM5Z18VT1	0W	16.8	18	19.1	2	45	225	1.0	0.05	12.6	12.4	16	100
MM5Z20VT1	0Z	18.8	20	21.2	2	55	225	1.0	0.05	14.0	14.4	18	85
MM5Z22VT1	10	20.8	22	23.3	2	55	250	1.0	0.05	15.4	16.4	20	85
MM5Z24VT1	11	22.8	24.4	25.6	2	70	120	1.0	0.05	16.8	18.4	22	80
MM5Z27VT1	12	25.1	27	28.9	2	80	300	1.0	0.05	18.9	21.4	25.3	70
MM5Z30VT1	14	28	30	32	2	80	300	1.0	0.05	21.0	24.4	29.4	70
MM5Z33VT1	18	31	33	35	2	80	300	1.0	0.05	23.2	27.4	33.4	70
MM5Z36VT1	19	34	36	38	2	90	500	1.0	0.05	25.2	30.4	37.4	70
MM5Z39VT1	20	37	39	41	2	130	500	1.0	0.05	27.3	33.4	41.2	45
MM5Z43VT1	21	40	43	46	1	150	500	1.0	0.05	30.1	37.6	46.6	40
MM5Z47VT1	1A	44	47	50	1	170	500	1.0	0.05	32.9	42.0	51.8	40
MM5Z51VT1	1C	48	51	54	1	180	500	1.0	0.05	35.7	46.6	57.2	40
MM5Z56VT1	1D	52	56	60	1	200	500	1.0	0.05	39.2	52.2	63.8	40
MM5Z62VT1	1E	58	62	66	1	215	500	1.0	0.05	43.4	58.8	71.6	35
MM5Z68VT1	1F	64	68	72	1	240	500	1.0	0.05	47.6	65.6	79.8	35
MM5Z75VT1	1G	70	75	79	1	255	500	1.0	0.05	52.5	73.4	88.6	35

1. Zener voltage is measured with a pulse test current  $I_z$  at an ambient temperature of  $25^\circ\text{C}$ .

# Outline Drawing

# SOD-523

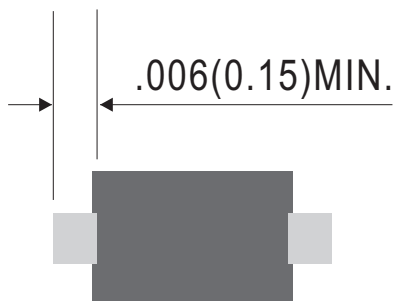
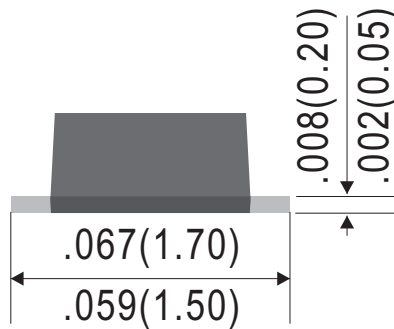
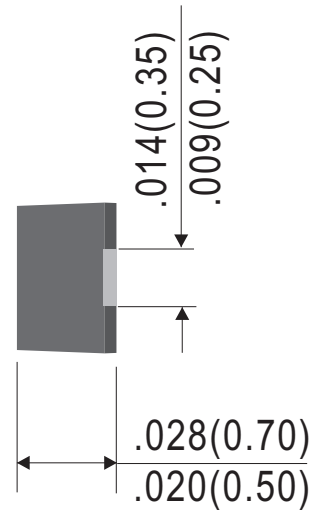
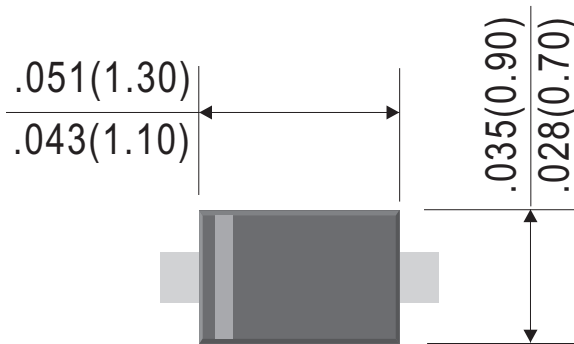

Dimensions in inches and (millimeters)