

3.0 Amp Glass Passivated Silicon Rectifiers - 50~1000Volts

SMB Package



SMB(DO-214AA)

Features

- Glass Passivated Chip
- Ideal for surface mounted applications
- Low leakage current
- Metallurgic ally bonded construction
- Moisture Sensitivity Level 1
- RoHS product for packing code suffix "G"
Halogen free product for packing code suffix "H"

Mechanical Date

- Case: Molded Plastic, SMB(DO214AA)
- Epoxy: UL 94V-0 Rate Flame Retardant
- Lead: Solderable per MIL-STD-202,
method 208 guaranteed
- Polarity: Color band denotes cathode end
- Mounting Position: Any
- Weight: 0.004 ounce, 0.104 gram (Approximate)

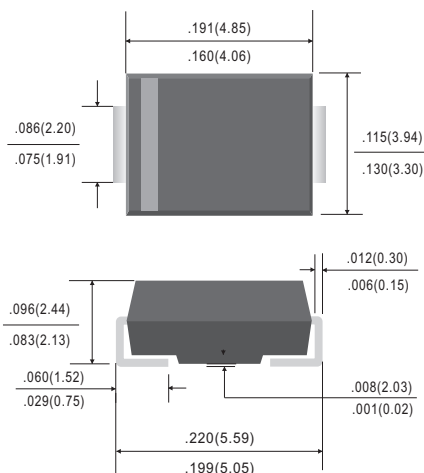

Dimensions in inches and (millimeters)

MAXIMUM RATINGS AND ELECTRICAL CHARACTERISTICS

Ratings at 25°C ambient temperature unless otherwise specified.

Single phase half wave, 60Hz, resistive of inductive load.

For capacitive load, derate current by 20%

RATING		SYMBOLS	FM301B	FM302B	FM303B	FM304B	FM305B	FM306B	FM307B	UNITS	
Marking code			3B1	3B2	3B3	3B4	3B5	3B6	3B7		
Maximum Recurrent Peak Reverse Voltage		V_{RRM}	50	100	200	400	600	800	1000	Volts	
Maximum RMS Voltage		V_{RMS}	35	70	140	280	420	560	700	Volts	
Maximum DC Blocking Voltage		V_{DC}	50	100	200	400	600	800	1000	Volts	
Maximum Average Forward rectifier Current 0.375" (9.5mm) Lead length at Fig.1		$I_{F(AV)}$	3.0								Amps
Peak Forward Surge Current 8.3 ms single half sine-wave superimposed on rated load (JEDEC method)		I_{FSM}	100								Amps
Maximum Instantaneous Forward Voltage at 3.0A DC		V_F	1.1								Volts
Maximum DC Reverse Current at Rated DC Blocking Voltage	@ Ta=25°C	I_R	5.0								μA
	@ Ta=100°C		100								
Typical Thermal Resistance (Note 2)		$R_{\theta JA}$	40								$^{\circ}C/W$
		$R_{\theta JC}$	15								
Typical Junction Capacitance(Note 1)		C_J	60								pF
Operating and Storage Temperature Range		T_J, T_{STG}	-55 ~ 150								$^{\circ}C$

Notes:

1. Measured at 1MHz and applied reverse voltage of 4.0VDC.
2. Thermal Resistance junction to ambient, 10.0*10.0 mm² copper pads to each terminal.
Thermal Resistance junction to case, 10.0*10.0 mm² copper pads to each terminal.

RATING AND CHARACTERISTICS CURVES

FIG. 1 - TYPICAL FORWARD CURRENT DERATING CURVE

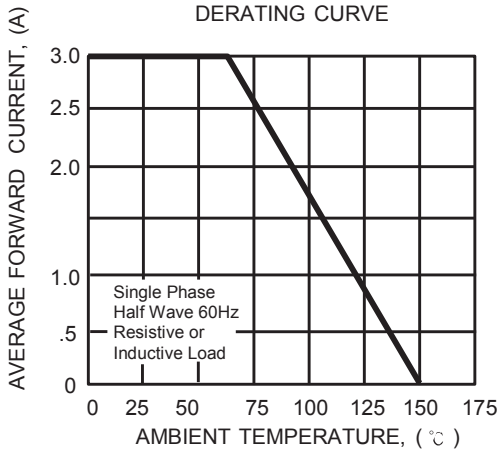

FIG. 2 - TYPICAL INSTANTANEOUS FORWARD CHARACTERISTICS

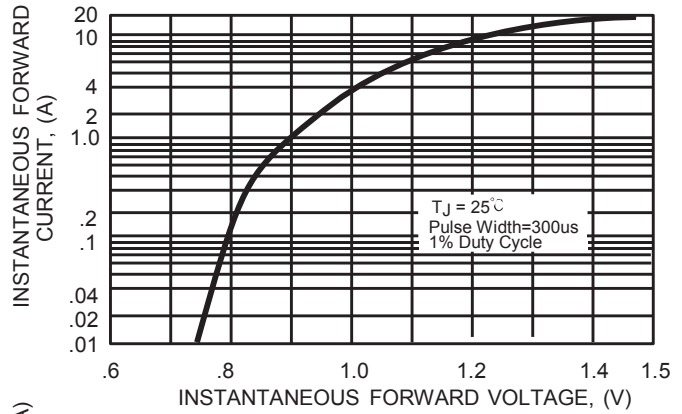

FIG. 3 - MAXIMUM NON-REPETITIVE FORWARD SURGE CURRENT

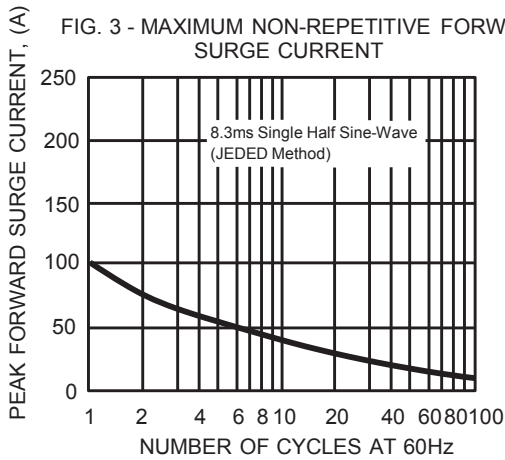

FIG. 4 - TYPICAL REVERSE CHARACTERISTICS

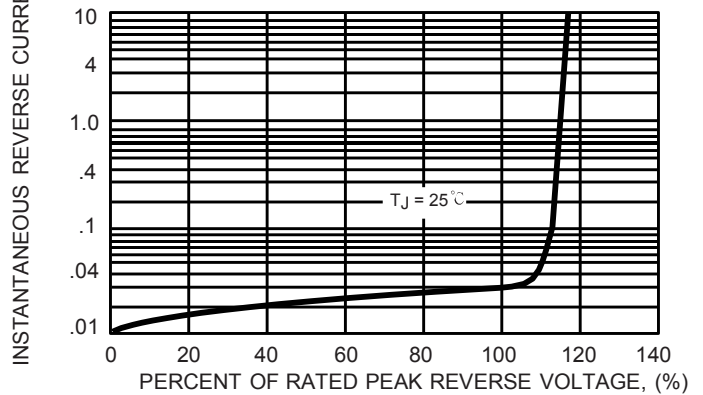

FIG. 5 - TYPICAL JUNCTION CAPACITANCE

