

2.0A Surface Mount High Efficiency Rectifiers -50V- 1000V
SMB PACKAGE
FEATURES

- * Glass passivated device
- * Ideal for surface mounted applications
- * Low leakage current
- * Metallurgically bonded construction
- * Moisture Sensitivity Level 1
- * **Pb-Free package is available**
 RoHS product for packing code suffix "G"
 Halogen free product for packing code suffix "H"

MECHANICAL DATA

- * Case: Molded plastic, DO-214AA (SMB)
- * Epoxy: Device has Ulflammability classification 94V-O
- * Lead: MIL-STD-202E method 208C guaranteed
- * Mounting position: Any
- * Weight: 0.093 gram (Approximated)

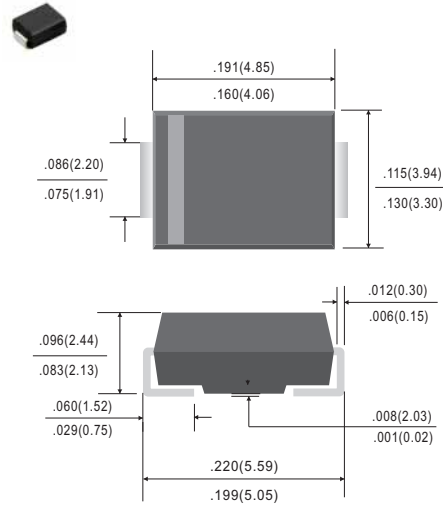

Dimensions in inches and (millimeters)

MAXIMUM RATINGS AND ELECTRICAL CHARACTERISTICS

Ratings at 25°C ambient temperature unless otherwise specified.
 Single phase half wave, 60Hz, resistive of inductive load.
 For capacitive load, derate current by 20%

RATINGS	SYMBOL	HFM201	HFM202	HFM203	HFM204	HFM205	HFM206	HFM207	HFM208	UNIT
Marking Code		2H1	2H2	2H3	2H4	2H5	2H6	2H7	2H8	
Maximum Recurrent Peak Reverse Voltage	VRRM	50	100	200	300	400	600	800	1000	Volts
Maximum RMS Voltage	VRMS	35	70	140	210	280	420	560	700	Volts
Maximum DC Blocking Voltage	VDC	50	100	200	300	400	600	800	1000	Volts
Maximum Average Forward Current at TA = 50°C	Io	2.0								Amps
Peak Forward Surge Current 8.3 ms single half sine-wave superimposed on rated load (JEDEC method)	IFSM	50								Amps
Typical Thermal Resistance (Note 1)	ROJA	70								°C/W
	ROJC	20								
Typical Junction Capacitance (Note 2)	CJ	30				20				pF
Operating Temperature Range	TJ	-55 to +150								°C
Storage Temperature Range	TsTg	-55 to +150								°C

CHARACTERISTICS	SYMBOL	HFM201	HFM202	HFM203	HFM204	HFM205	HFM206	HFM207	HFM208	UNIT
Maximum Forward Voltage at 2.0A DC	VF	1.00			1.30		1.70			Volts
Maximum Full load Reverse Current, Full cycle Average TA=55°C	IR	50.00								µAmps
Maximum DC Reverse Current @ TA = 25°C		5.0								
at Rated DC Blocking Voltage @ TA = 125°C		100.0								
Maximum Reverse Recovery Time (Note 3)	Trr	50				75				nSec

NOTES :1.Thermal Resistance: Mounted on PCB.

2. Measured at 1 MHz and applied reverse voltage of 4.0 volts.

3.Test Conditions: IF = 0.5A, IR = 1.0A, IRR = 0.25A

RATING AND CHARACTERISTIC CURVES (HFM201 THRU HFM208)

FIG. 1 - TEST CIRCUIT DIAGRAM AND REVERSE RECOVERY TIME CHARACTERISTIC

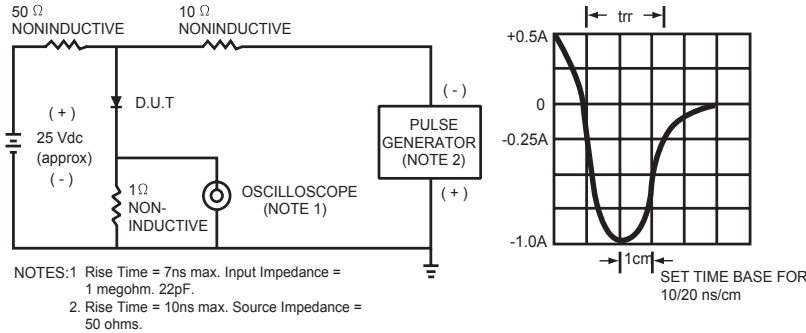

FIG. 2 - TYPICAL FORWARD CURRENT DERATING CURVE

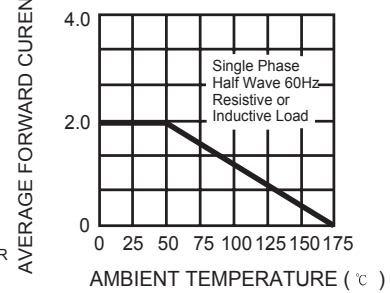

FIG. 3 - TYPICAL REVERSE CHARACTERISTICS

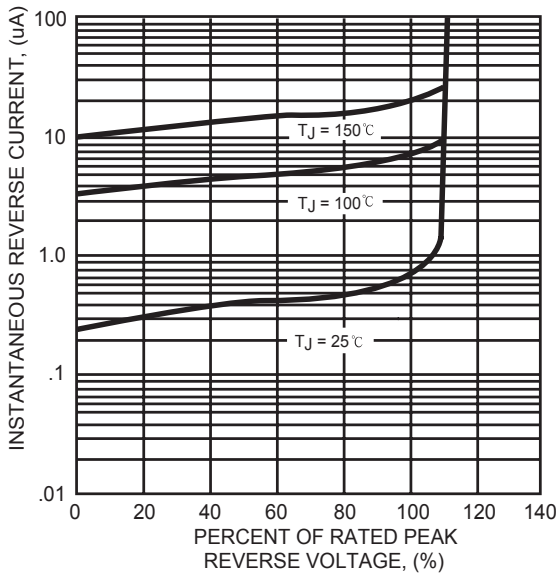

FIG. 4 - TYPICAL INSTANTANEOUS FORWARD CHARACTERISTICS

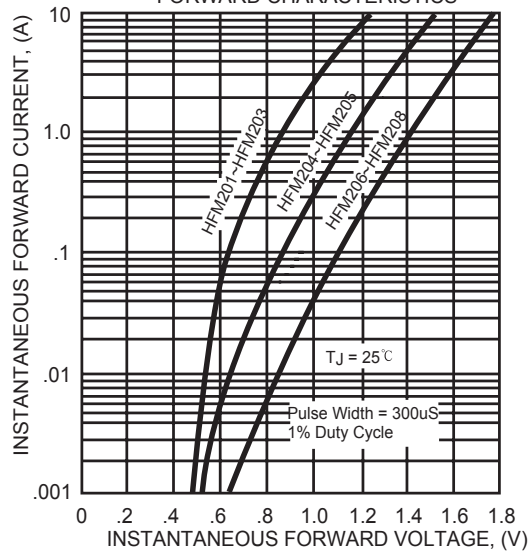

FIG. 5 - MAXIMUM NON-REPETITIVE FORWARD SURGE CURRENT

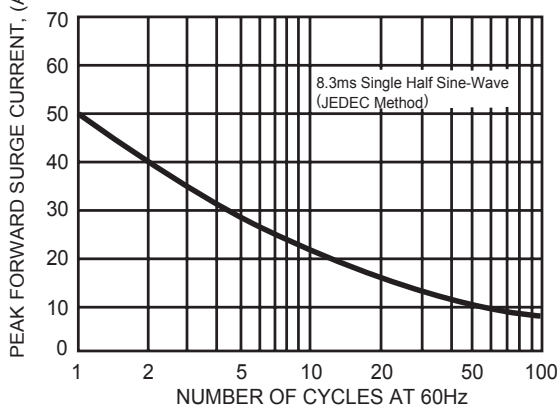

FIG. 6 - TYPICAL JUNCTION CAPACITANCE

