

## FEATURES

- \* Batch process design, excellent power dissipation offers better reverse leakage current and thermal resistance.
- \* Low profile surface mounted application in order to optimize board space.
- \* Low power loss, high efficiency.
- \* High current capability, low forward voltage drop.
- \* High surge capability.
- \* Ultra high-speed switching.
- \* Lead-free parts meet environmental standards of MIL-STD-19500/228
- \* RoHS product for packing code suffix "G"  
Halogen free product for packing code suffix "H"

## MECHANICAL DATA

Case: Molded plastic, SOD-323-L  
Epoxy: UL 94V-O rate flame retardant  
Terminals: Solder plated, solderable per MIL-STD-750, Method 2026.  
Mounting position: Any  
Weight: Approximated 0.008 gram.

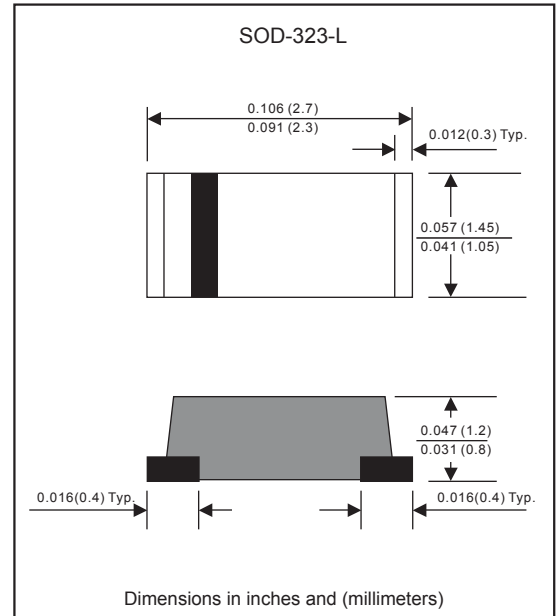

## MAXIMUM RATINGS AND ELECTRICAL CHARACTERISTICS

Ratings at 25°C ambient temperature unless otherwise specified.

Single phase half wave, 60Hz, resistive or inductive load.

For capacitive load, derate current by 20%

RATINGS	SYMBOL	FM0520-N	FM0530-N	FM0540-N	FM0550-N	FM0560-N	FM0580-N	FM05100-N	UNIT
Marking Code		A	B	C	D	E	F	G	
Maximum Recurrent Peak Reverse Voltage	V <sub>RRM</sub>	20	30	40	50	60	80	100	Volts
Maximum RMS Voltage	V <sub>RMS</sub>	14	21	28	35	42	56	70	Volts
Maximum DC Blocking Voltage	V <sub>DC</sub>	20	30	40	50	60	80	100	Volts
Maximum Average Forward Rectified Current	I <sub>O</sub>	0.5							Amps
Peak Forward Surge Current 8.3 ms single half sine-wave superimposed on rated load (JEDEC method)	I <sub>FSM</sub>	15							Amps
Typical Thermal Resistance (Note 2)	R <sub>θJA</sub>	90							°C/W
Typical Junction Capacitance (Note 1)	C <sub>J</sub>	120							pF
Operating Temperature Range	T <sub>J</sub>	-55 to +125			-55 to +150				°C
Storage Temperature Range	T <sub>STG</sub>	-55 to +150							°C

CHARACTERISTICS	SYMBOL	FM0520-N	FM0530-N	FM0540-N	FM0550-N	FM0560-N	FM0580-N	FM05100-N	UNIT
Maximum Forward Voltage at 0.5A DC	V <sub>F</sub>	0.50			0.65		0.80		Volts
Maximum Average Reverse Current at Rated DC Blocking Voltage	I <sub>R</sub>	0.5							mAmps
		10							

### NOTES:

- 1- Measured at 1 MHz and applied reverse voltage of 4.0 VDC.
- 2- Thermal Resistance From Junction to Ambient

## RATING AND CHARACTERISTIC CURVES

FIG.1-TYPICAL FORWARD CURRENT DERATING CURVE

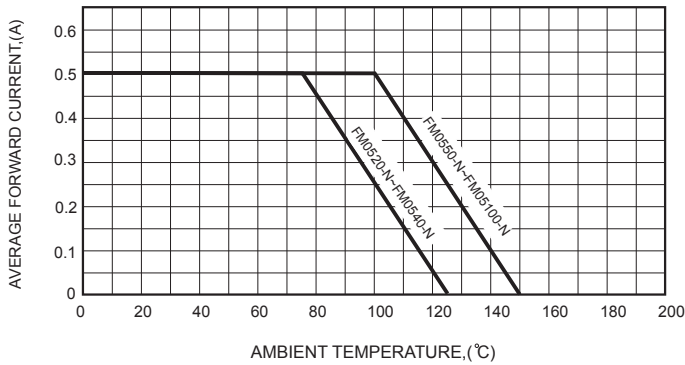

FIG.2-TYPICAL FORWARD CHARACTERISTICS

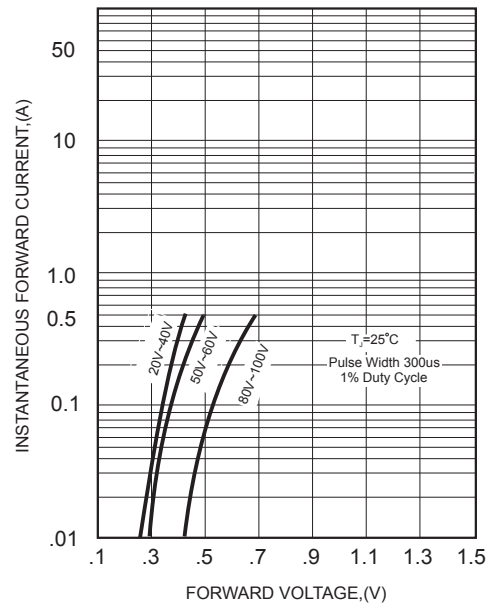

FIG.3-MAXIMUM NON-REPETITIVE FORWARD SURGE CURRENT

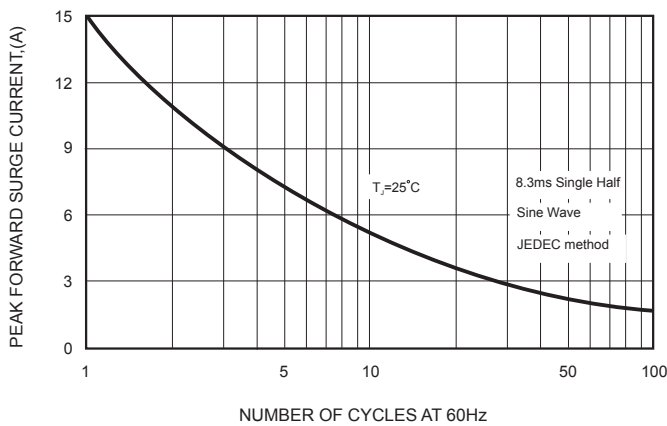

FIG.5 - TYPICAL REVERSE CHARACTERISTICS

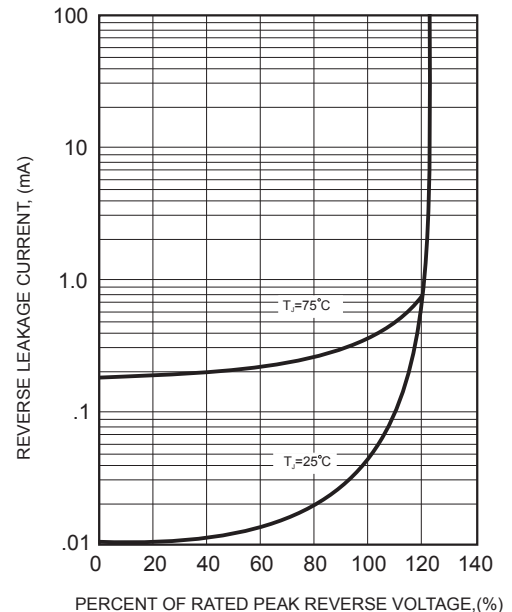

FIG.4-TYPICAL JUNCTION CAPACITANCE

