



SOD-523 Plastic-Encapsulate Diodes

Schottky barrier Diode

FEATURES

- Small surface mounting type
- Low I_R
- High reliability
- **Pb-Free package is available**
RoHS product for packing code suffix "G"
Halogen free product for packing code suffix "H"
- Moisture Sensitivity Level 1

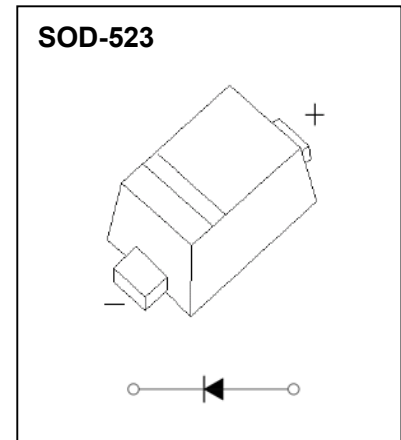

MARKING: B&5J

Maximum Ratings and Electrical Characteristics, Single Diode @Ta=25°C

Parameter	Symbol	Limit	Unit
DC reverse voltage	V_R	30	V
Mean rectifying current	I_O	200	mA
Peak forward surge current	I_{FSM}	1	A
Power dissipation	P_D	150	mW
Thermal resistance junction to ambient	$R_{\theta JA}$	667	°C/W
Operating temperature	T_j	-55~+125	°C
Storage temperature	T_{stg}	-55~+150	°C

Electrical Ratings @Ta=25°C

Parameter	Symbol	Min	Typ	Max	Unit	Conditions
Forward voltage	V_F			0.6	V	$I_F=200mA$
Reverse current	I_R			1	μA	$V_R=10V$



Typical Characteristics

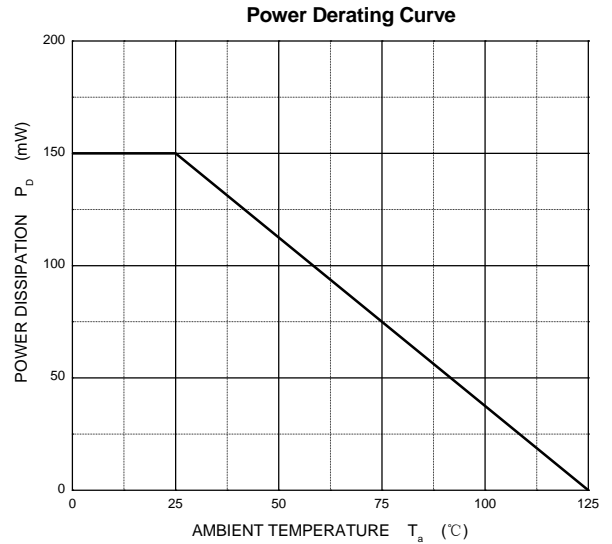
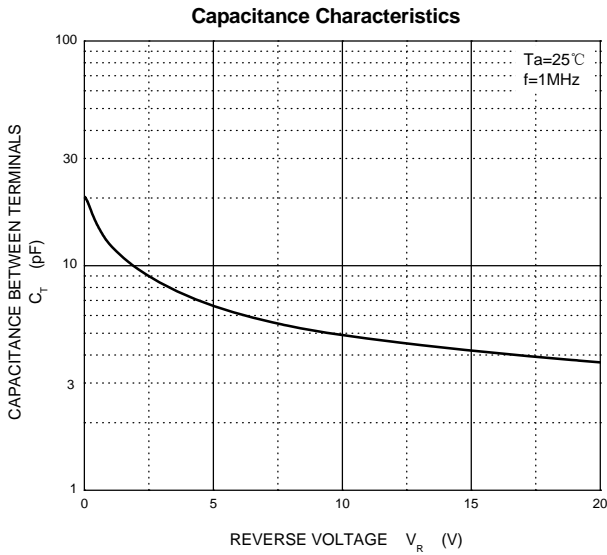
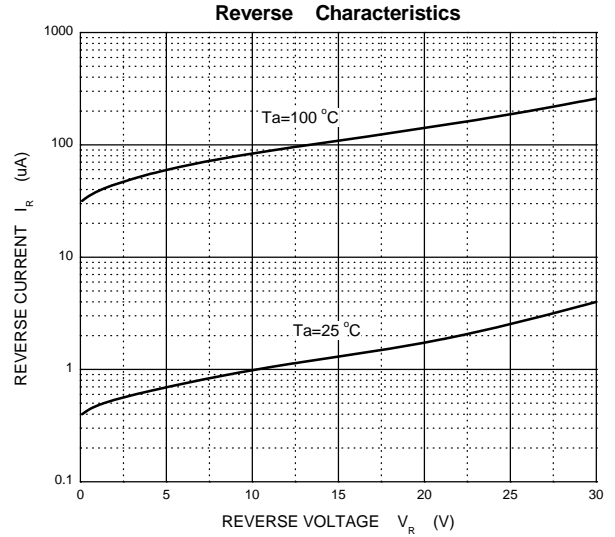
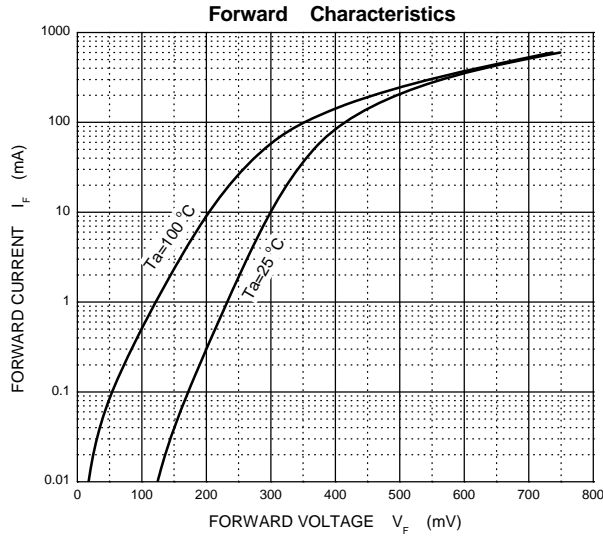



Outline Drawing

SOD-523

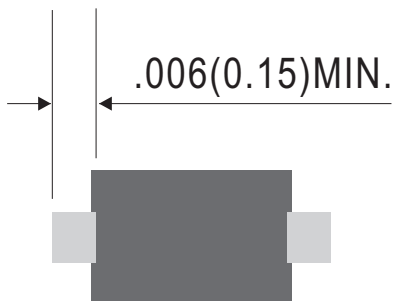
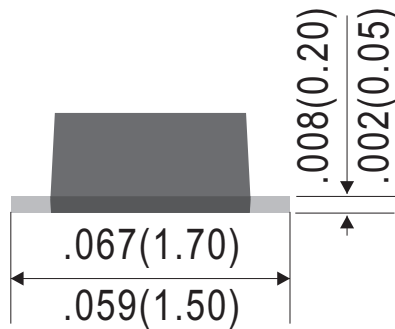
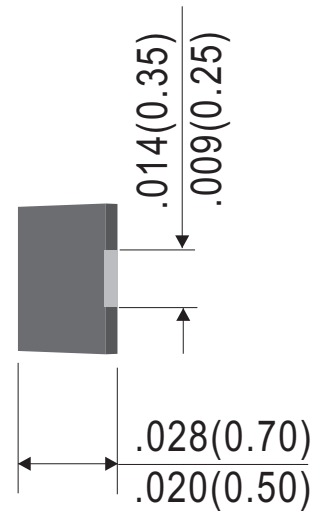
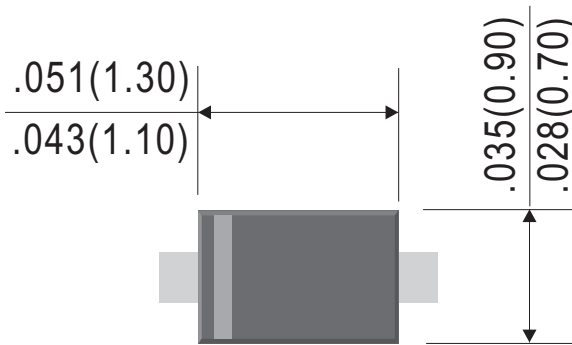

Dimensions in inches and (millimeters)



Ordering Information:

Device PN	Packing
SCS520S -T ⁽¹⁾ G ⁽²⁾ -WS	Tape&Reel: 3 Kpcs/Reel

Note: (1) Packing code, Tape & Reel Packing

(2) RoHS product for packing code suffix "G" ; Halogen free product for packing code suffix "H"

*****Disclaimer*****

WILLAS reserves the right to make changes without notice to any product specification herein, to make corrections, modifications, enhancements or other changes. WILLAS or anyone on its behalf assumes no responsibility or liability for any errors or inaccuracies. Data sheet specifications and its information contained are intended to provide a product description only. "Typical" parameters which may be included on WILLAS data sheets and/ or specifications can and do vary in different applications and actual performance may vary over time. WILLAS does not assume any liability arising out of the application or use of any product or circuit.

WILLAS products are not designed, intended or authorized for use in medical, life-saving implant or other applications intended for life-sustaining or other related applications where a failure or malfunction of component or circuitry may directly or indirectly cause injury or threaten a life without expressed written approval of WILLAS. Customers using or selling WILLAS components for use in such applications do so at their own risk and shall agree to fully indemnify WILLAS Inc and its subsidiaries harmless against all claims, damages and expenditures.