

# General Purpose Transistors

BCK \* ) 5 LT1

## NPN Silicon

### Features

We declare that the material of product compliance with RoHS requirements.

**Pb-Free package is available**

RoHS product for packing code suffix "G"

Halogen free product for packing code suffix "H"

Moisture Sensitivity Level 1

### MAXIMUM RATINGS

Rating	Symbol	Value	Unit
Collector–Emitter Voltage	$V_{CEO}$	32	Vdc
Collector–Base Voltage	$V_{CBO}$	60	Vdc
Emitter–Base Voltage	$V_{EBO}$	5.0	Vdc
Collector Current — Continuous	$I_C$	800	mAdc



### THERMAL CHARACTERISTICS

Characteristic	Symbol	Max	Unit
Total Device Dissipation FR–5 Board, (1) $T_A = 25^\circ\text{C}$	$P_D$	225	mW
Derate above $25^\circ\text{C}$		1.8	mW/ $^\circ\text{C}$
Thermal Resistance, Junction to Ambient	$R_{\theta JA}$	556	$^\circ\text{C}/\text{W}$
Total Device Dissipation Alumina Substrate, (2) $T_A = 25^\circ\text{C}$	$P_D$	300	mW
Derate above $25^\circ\text{C}$		2.4	mW/ $^\circ\text{C}$
Thermal Resistance, Junction to Ambient	$R_{\theta JA}$	417	$^\circ\text{C}/\text{W}$
Junction and Storage Temperature	$T_J, T_{stg}$	-55 to +150	$^\circ\text{C}$

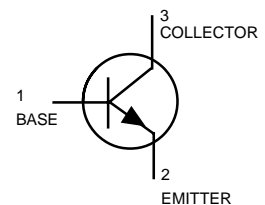

### DEVICE MARKING

BCW65ALT1 = EA

### ELECTRICAL CHARACTERISTICS ( $T_A = 25^\circ\text{C}$ unless otherwise noted.)

Characteristic	Symbol	Min	Typ	Max	Unit
----------------	--------	-----	-----	-----	------

### OFF CHARACTERISTICS

Collector–Emitter Breakdown Voltage ( $I_C = 10\text{mAdc}, I_E = 0$ )	$V_{(BR)CEO}$	32	—	—	Vdc
Collector–Emitter Breakdown Voltage ( $I_C = 10\ \mu\text{Adc}, V_{EB} = 0$ )	$V_{(BR)CES}$	60	—	—	Vdc
Emitter–Base Breakdown Voltage ( $I_E = 10\ \mu\text{Adc}, I_C = 0$ )	$V_{(BR)EBO}$	5.0	—	—	Vdc
Collector Cutoff Current ( $V_{CE} = 32\ \text{Vdc}, I_E = 0$ )	$I_{CES}$	—	—	20	nAdc
( $V_{CE} = 32\ \text{Vdc}, I_E = 0, T_A = 150^\circ\text{C}$ )		—	—	20	$\mu\text{Adc}$
Emitter Cutoff Current ( $V_{EB} = 4.0\ \text{Vdc}, I_C = 0$ )	$I_{EBO}$	—	—	20	nAdc

1. FR–5 =  $1.0 \times 0.75 \times 0.062$  in.

2. Alumina =  $0.4 \times 0.3 \times 0.024$  in. 99.5% alumina.

**ELECTRICAL CHARACTERISTICS** ( $T_A = 25^\circ\text{C}$  unless otherwise noted) (Continued)

Characteristic	Symbol	Min	Typ	Max	Unit
<b>ON CHARACTERISTICS</b>					
DC Current Gain ( $I_C = 100 \mu\text{Adc}$ , $V_{CE} = 10 \text{Vdc}$ )	$h_{FE}$	35	—	—	—
( $I_C = 10 \text{mAdc}$ , $V_{CE} = 1.0 \text{Vdc}$ )		75	—	220	
( $I_C = 100 \text{mAdc}$ , $V_{CE} = 1.0 \text{Vdc}$ )		100	—	250	
( $I_C = 500 \text{mAdc}$ , $V_{CE} = 2.0 \text{Vdc}$ )		35	—	—	
Collector–Emitter Saturation Voltage ( $I_C = 500 \text{mAdc}$ , $I_B = 50 \text{mAdc}$ )	$V_{CE(sat)}$	—	0.7	—	Vdc
( $I_C = 100 \text{mAdc}$ , $I_B = 10 \text{mAdc}$ )		—	0.3	—	
Base–Emitter Saturation Voltage ( $I_C = 500 \text{mAdc}$ , $I_B = 50 \text{mAdc}$ )	$V_{BE(sat)}$	—	—	2.0	Vdc

**SMALL–SIGNAL CHARACTERISTICS**

Current–Gain — Bandwidth Product ( $I_C = 20 \text{mAdc}$ , $V_{CE} = 10 \text{Vdc}$ , $f = 100 \text{MHz}$ )	$f_T$	100	—	—	MHz
Output Capacitance ( $V_{CB} = 10 \text{Vdc}$ , $I_E = 0$ , $f = 1.0 \text{MHz}$ )	$C_{obo}$	—	—	12	pF
Input Capacitance ( $V_{EB} = 0.5 \text{Vdc}$ , $I_C = 0$ , $f = 1.0 \text{MHz}$ )	$C_{ibo}$	—	—	80	pF
Noise Figure ( $V_{CE} = 5.0 \text{Vdc}$ , $I_C = 0.2 \text{mAdc}$ , $R_s = 2.0 \text{k}\Omega$ , $f = 1.0 \text{kHz}$ , $BW = 200 \text{Hz}$ )	NF	—	—	10	dB

**SWITCHING CHARACTERISTICS**

Turn–On Time ( $I_{B1} = I_{B2} = 15 \text{mAdc}$ )	$t_{on}$	—	—	100	ns
Turn–Off Time ( $I_C = 150 \text{mAdc}$ , $R_L = 150 \Omega$ )	$t_{off}$	—	—	400	ns

**Ordering Information**

Device	Marking	Shipping
BCW65ALT1	EA	3000/Tape&Reel

**SOT-23**

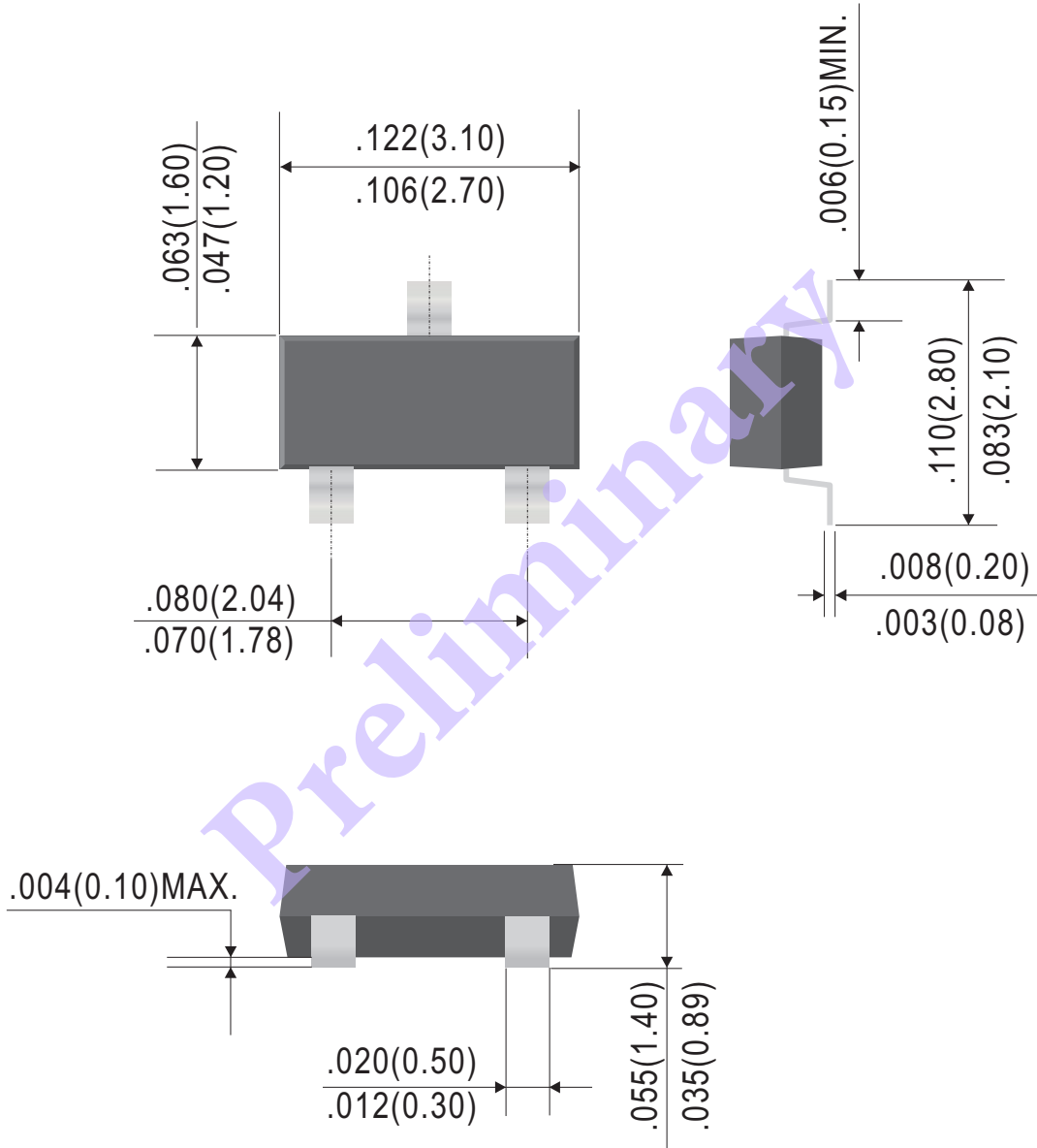

Dimensions in inches and (millimeters)



# WILLAS



## General Purpose Transistors

BCK \* ) 5 LT1

### Ordering Information:

Device PN	Packing
BCW65ALT1 G <sup>(1)</sup> -WS	Tape&Reel: 3 Kpcs/Reel

Note: (1) RoHS product for packing code suffix "G" ; Halogen free product for packing code suffix "H"

### \*\*\*Disclaimer\*\*\*

WILLAS reserves the right to make changes without notice to any product specification herein, to make corrections, modifications, enhancements or other changes. WILLAS or anyone on its behalf assumes no responsibility or liability for any errors or inaccuracies. Data sheet specifications and its information contained are intended to provide a product description only. "Typical" parameters which may be included on WILLAS data sheets and/ or specifications can and do vary in different applications and actual performance may vary over time. WILLAS does not assume any liability arising out of the application or use of any product or circuit.

WILLAS products are not designed, intended or authorized for use in medical, life-saving implant or other applications intended for life-sustaining or other related applications where a failure or malfunction of component or circuitry may directly or indirectly cause injury or threaten a life without expressed written approval of WILLAS. Customers using or selling WILLAS components for use in such applications do so at their own risk and shall agree to fully indemnify WILLAS Inc and its subsidiaries harmless against all claims, damages and expenditures.