

PNP Silicon

FEATURE

We declare that the material of product compliance with RoHS requirements.

Pb-Free package is available

RoHS product for packing code suffix "G"

Halogen free product for packing code suffix "H"

Moisture Sensitivity Level 1

DEVICE MARKING AND ORDERING INFORMATION

Device	Marking	Shipping
8550PLT1	85P	3000/Tape&Reel
8550QLT1	1YD	3000/Tape&Reel
8550RLT1	1YF	3000/Tape&Reel



MAXIMUM RATINGS

Rating	Symbol	Value	Unit
Collector-Emitter Voltage	V_{CEO}	25	V
Collector-Base voltage	V_{CBO}	40	V
Emitter-base Voltage	V_{EBO}	5	V
Collector current-continuoun	I_C	800	mAdc

THERMAL CHARACTERISTICS

Characteristic	Symbol	Max	Unit
Total Device Dissipation FR- 5 Board (1) $T_A = 25\text{ }^\circ\text{C}$	P_D	225	mW
Derate above 25 °C		1.8	mW/°C
Thermal Resistance, Junction to Ambient	$R_{\theta JA}$	556	°C/W
Total Device Dissipation Alumina Substrate, (2) $T_A = 25\text{ }^\circ\text{C}$	P_D	300	mW
Derate above 25 °C		2.4	mW/°C
Thermal Resistance, Junction to Ambient	$R_{\theta JA}$	417	°C/W
Junction and Storage Temperature	T_J, T_{stg}	-55 to +150	°C

DEVICEMARKING

8550QLT1 = 1YD 8550PLT1 = 85P

ELECTRICAL CHARACTERISTICS ($T_A = 25\text{ }^\circ\text{C}$ unless otherwise noted)

Characteristic	Symbol	Min	Typ	Max	Unit
----------------	--------	-----	-----	-----	------

OFF CHARACTERISTICS

Collector-Emitter Breakdown Voltage ($I_C = 1.0\text{mA}$)	$V_{(BR)CEO}$	25	–	–	V
Emitter-Base Breakdown Voltage ($I_E = 100\mu\text{A}$)	$V_{(BR)EBO}$	5	–	–	V
Collector-Base Breakdown voltage ($I_C = 100\mu\text{A}$)	$V_{(BR)CBO}$	40	–	–	V
Collector Cutoff Current ($V_{CB} = 35\text{V}$)	I_{CBO}	–	–	150	nA
Emitter Cutoff Current ($V_{EB} = 4\text{V}$)	I_{EBO}	–	–	150	nA

1. FR-5 = 1.0 x 0.75 x 0.062 in.

2. Alumina = 0.4 x 0.3 x 0.024 in. 99.5% alumina.

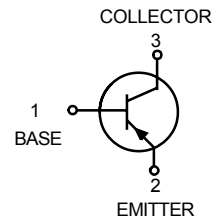

ON CHARACTERISTICS

Characteristic	Symbol	Min	Typ	Max	Unit
DC Current Gain ($I_C = 100\text{mA}$ $V_{CE} = 1\text{V}$)	h_{FE}	100	–	400	
Collector-Emitter Saturation Voltage ($I_C = 800\text{mA}$ $I_B = 80\text{mA}$)	$V_{CE(S)}$	–	–	0.5	V

NOTE:

*	P	Q	R
h_{FE}	100~200	150~300	200~400

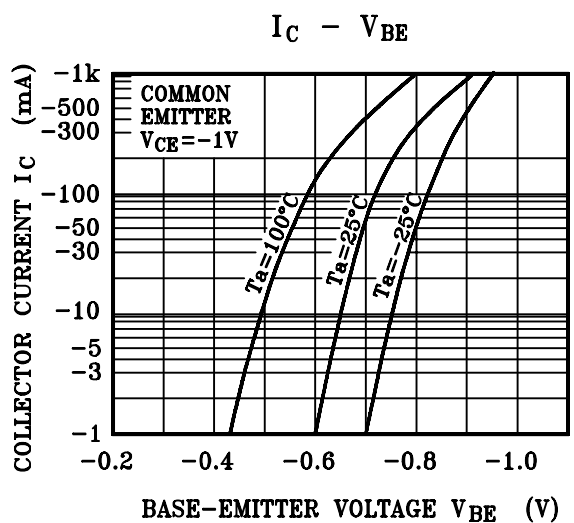
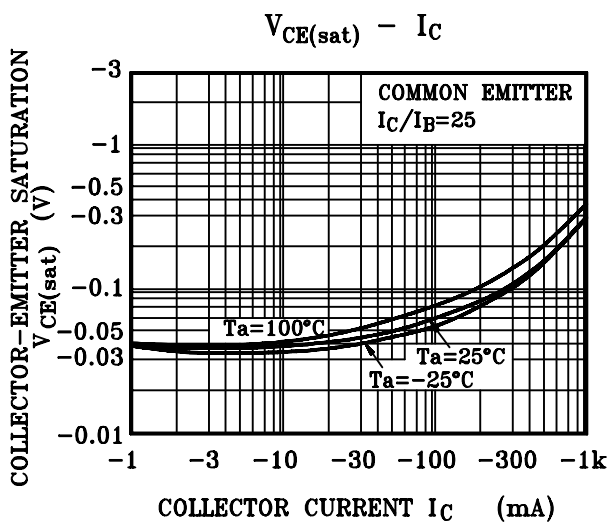
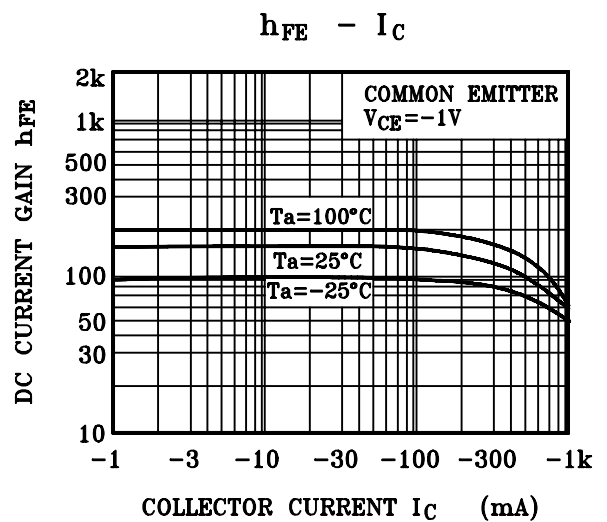
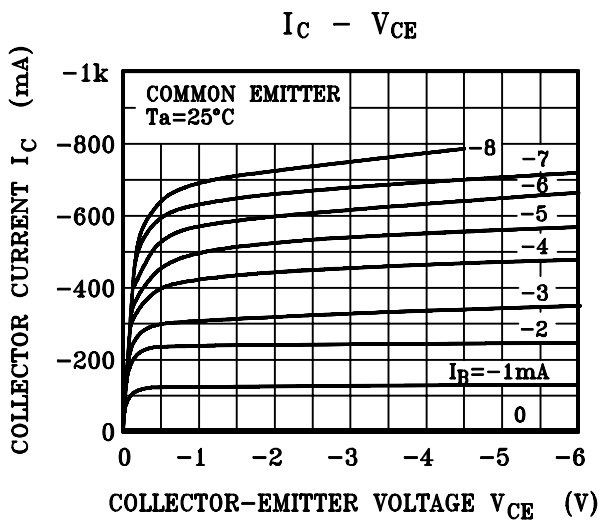

SOT-23

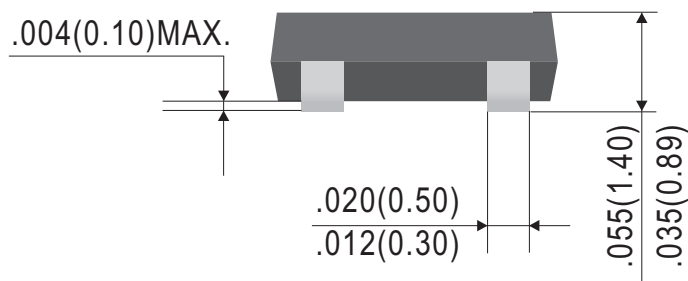
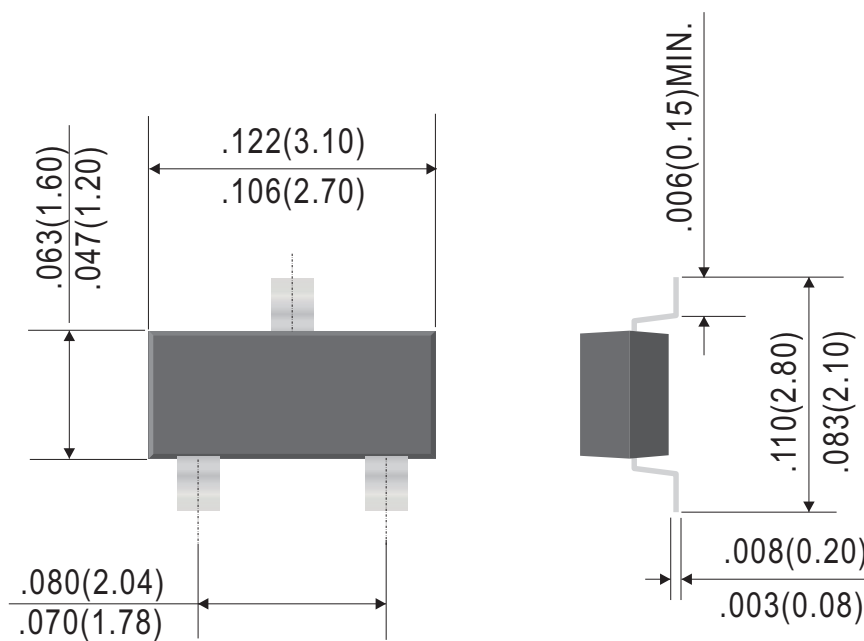

Dimensions in inches and (millimeters)

Ordering Information:

Device PN	Packing
8550 x ⁽²⁾ LT1 G ⁽¹⁾ -WS	Tape&Reel: 3 Kpcs/Reel

Note: (1) RoHS product for packing code suffix "G" ; Halogen free product for packing code suffix "H"

(2) CLASSIFICATION OF hFE RANK

*****Disclaimer*****

WILLAS reserves the right to make changes without notice to any product specification herein, to make corrections, modifications, enhancements or other changes. WILLAS or anyone on its behalf assumes no responsibility or liability for any errors or inaccuracies. Data sheet specifications and its information contained are intended to provide a product description only. "Typical" parameters which may be included on WILLAS data sheets and/ or specifications can and do vary in different applications and actual performance may vary over time. WILLAS does not assume any liability arising out of the application or use of any product or circuit.

WILLAS products are not designed, intended or authorized for use in medical, life-saving implant or other applications intended for life-sustaining or other related applications where a failure or malfunction of component or circuitry may directly or indirectly cause injury or threaten a life without expressed written approval of WILLAS. Customers using or selling WILLAS components for use in such applications do so at their own risk and shall agree to fully indemnify WILLAS Inc and its subsidiaries harmless against all claims, damages and expenditures.