

High Voltage Transistors

DEVICE MARKING AND ORDERING INFORMATION

Device	Marking	Shipping
MMBT5550LT1	M1F	3000/Tape&Reel
MMBT5551LT1	G1	3000/Tape&Reel

FEATURE

- We declare that the material of product compliance with RoHS requirements.
Pb-Free package is available
 RoHS product for packing code suffix "G"
 Halogen free product for packing code suffix "H"
Moisture Sensitivity Level 1

MAXIMUM RATINGS

Rating	Symbol	Value	Unit
Collector - Emitter Voltage MMBT5550 MMBT5551	V_{CEO}	140 160	Vdc
Collector - Base Voltage MMBT5550 MMBT5551	V_{CBO}	160 180	Vdc
Emitter - Base Voltage	V_{EBO}	6.0	Vdc
Collector Current - Continuous	I_C	600	mAdc

SOT-23
THERMAL CHARACTERISTICS

Characteristic	Symbol	Max	Unit
Total Device Dissipation FR-5 Board, (1) $T_A = 25^\circ\text{C}$	P_D	225	mW
Derate above 25°C		1.8	mW/ $^\circ\text{C}$
Thermal Resistance, Junction to Ambient	$R_{\theta JA}$	556	$^\circ\text{C/W}$
Total Device Dissipation Alumina Substrate, (2) $T_A = 25^\circ\text{C}$	P_D	300	mW
Derate above 25°C		2.4	mW/ $^\circ\text{C}$
Thermal Resistance, Junction to Ambient	$R_{\theta JA}$	417	$^\circ\text{C/W}$
Junction and Storage Temperature	T_J, T_{stg}	-55 to +150	$^\circ\text{C}$

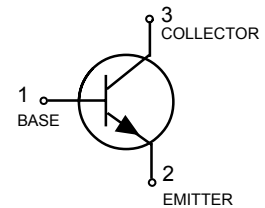
ELECTRICAL CHARACTERISTICS ($T_A = 25^\circ\text{C}$ unless otherwise noted.)

Characteristic	Symbol	Min	Max	Unit
----------------	--------	-----	-----	------

OFF CHARACTERISTICS

Collector-Emitter Breakdown Voltage(3) ($I_C = 1.0 \text{ mAdc}, I_E = 0$)	$V_{(BR)CEO}$			Vdc
MMBT5550		140	—	
MMBT5551		160	—	
Collector-Base Breakdown Voltage ($I_C = 100 \mu\text{Adc}, I_E = 0$)	$V_{(BR)CBO}$			Vdc
MMBT5550		160	—	
MMBT5551		180	—	
Emitter-Base Breakdown Voltage ($I_E = 10 \mu\text{Adc}, I_C = 0$)	$V_{(BR)EBO}$			Vdc
		6.0	—	
Collector Cutoff Current ($V_{CB} = 100\text{Vdc}, I_E = 0$)	I_{CBO}			nAdc
MMBT5550		—	100	
MMBT5551		—	50	
($V_{CB} = 100\text{Vdc}, I_E = 0, T_A = 100^\circ\text{C}$)				μAdc
MMBT5550		—	100	
MMBT5551		—	50	
Emitter Cutoff Current ($V_{BE} = 4.0\text{Vdc}, I_C = 0$)	I_{EBO}			nAdc
		—	50	

1. FR-5 = $1.0 \times 0.75 \times 0.062$ in.
2. Alumina = $0.4 \times 0.3 \times 0.024$ in. 99.5% alumina.
3. Pulse Test: Pulse Width = $300 \mu\text{s}$, Duty Cycle = 2.0%.

High Voltage Transistors

ELECTRICAL CHARACTERISTICS (T_A = 25°C unless otherwise noted) (Continued)

Characteristic		Symbol	Min	Max	Unit
ON CHARACTERISTICS					
DC Current Gain		h_{FE}			—
(I _C = 1.0 mA, V _{CE} = 5.0 Vdc)	MMBT5550		60	—	
	MMBT5551		80	—	
(I _C = 10 mA, V _{CE} = 5.0 Vdc)	MMBT5550		60	250	
	MMBT5551		80	250	
(I _C = 50 mA, V _{CE} = 5.0Vdc)	MMBT5550		20	—	
	MMBT5551		30	—	
Collector–Emitter Saturation Voltage		V _{CE(sat)}			Vdc
(I _C = 10 mA, I _B = 1.0 mA)	Both Types		—	0.15	
(I _C = 50 mA, I _B = 5.0 mA)	MMBT5550		—	0.25	
	MMBT5551		—	0.20	
Base–Emitter Saturation Voltage		V _{BE(sat)}			Vdc
(I _C = 10 mA, I _B = 1.0 mA)	Both Types		—	1.0	
(I _C = 50 mA, I _B = 5.0 mA)	MMBT5550		—	1.2	
	MMBT5551		—	1.0	

High Voltage Transistors

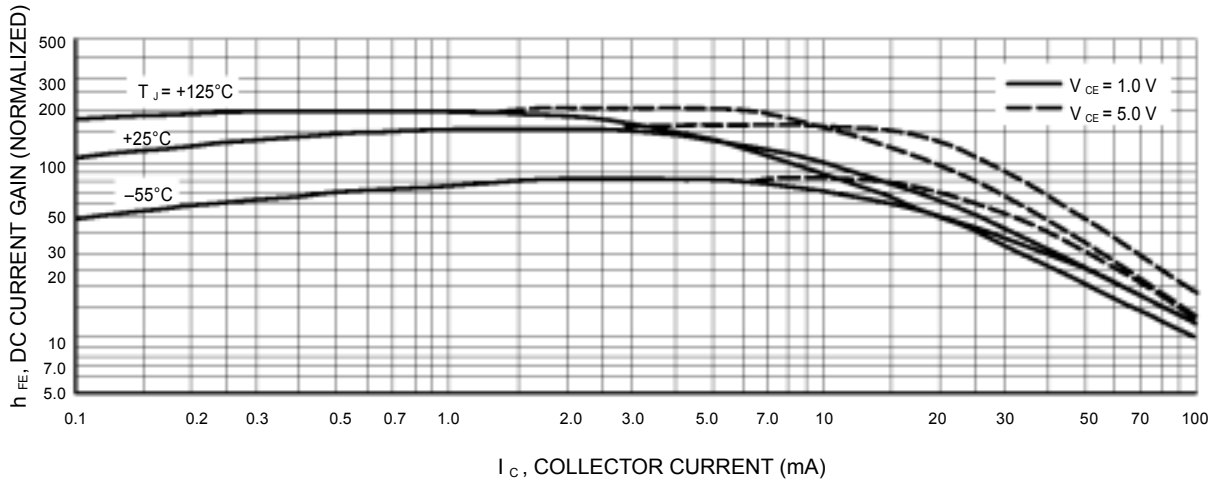

I_C , COLLECTOR CURRENT (mA)

Figure 15. DC Current Gain

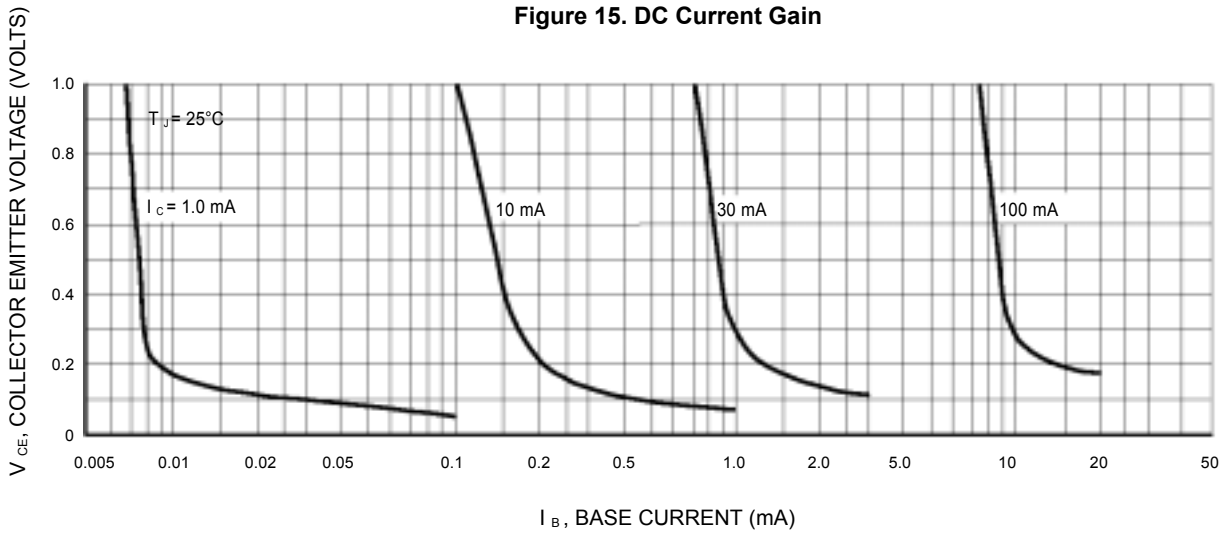

Figure 16. Collector Saturation Region

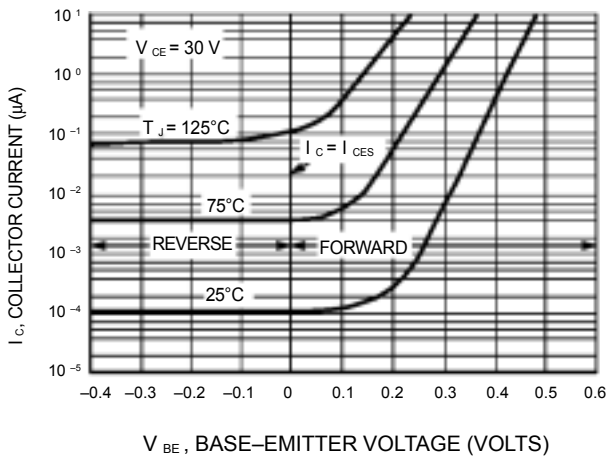

Figure 3. Collector Cut-Off Region

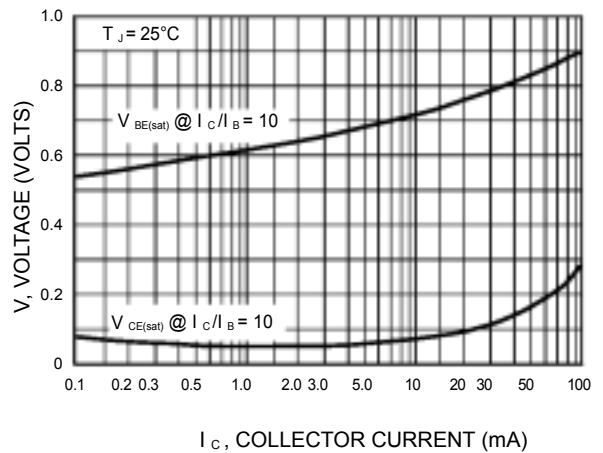

Figure 4. "On" Voltages

High Voltage Transistors

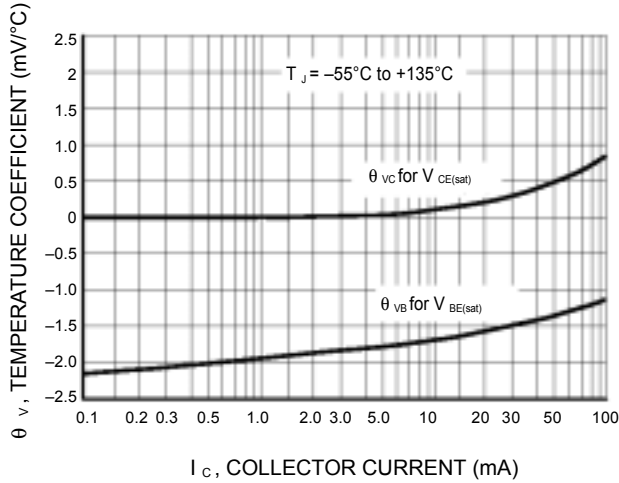
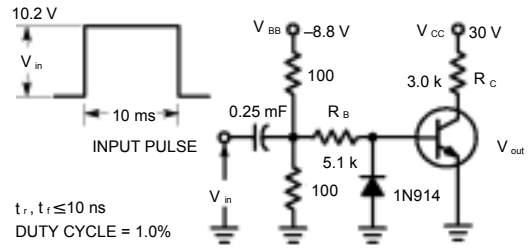

Figure 5. Temperature Coefficients



Values Shown are for $I_c @ 10 \text{ mA}$
Figure 6. Switching Time Test Circuit

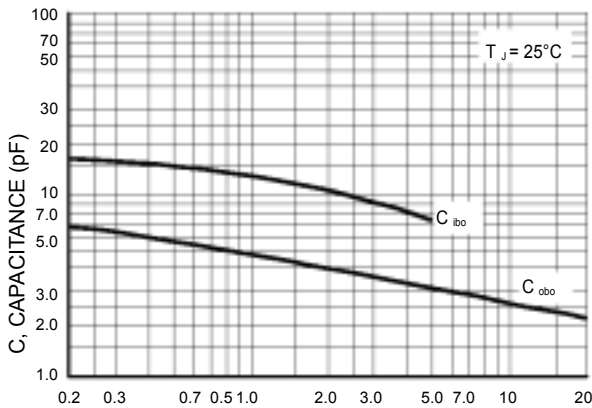
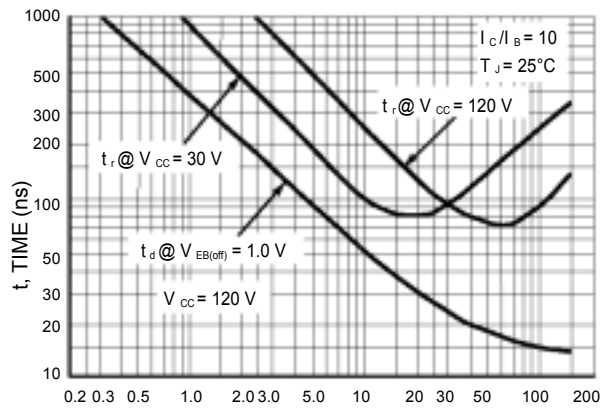

Figure 7. Capacitances Figure



8. Turn-On Time

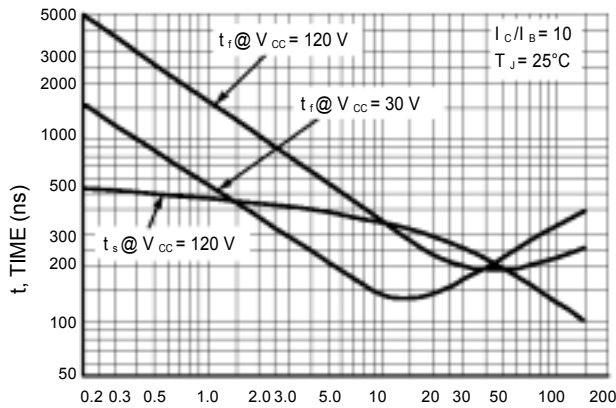
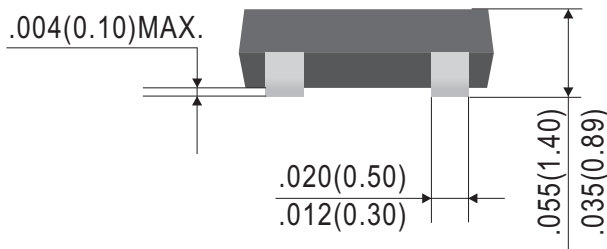
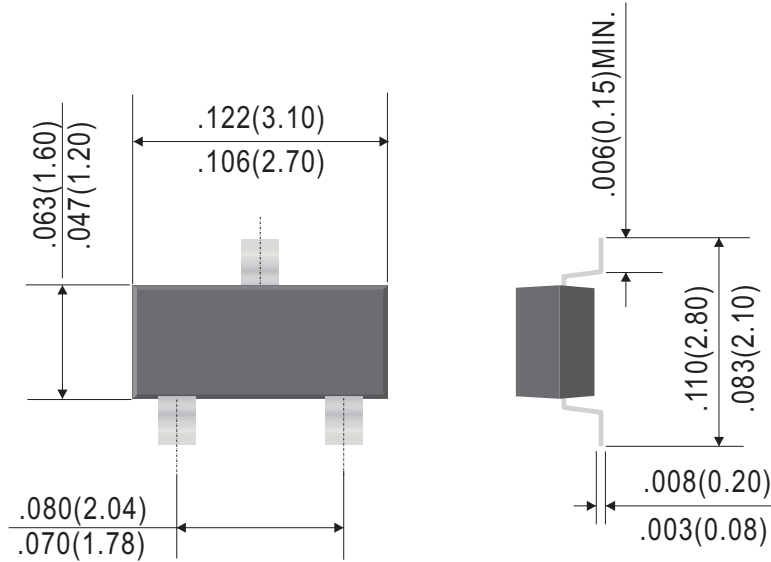

Figure 9. Turn-Off Time

High Voltage Transistors

SOT-23



Dimensions in inches and (millimeters)

High Voltage Transistors

Ordering Information:

Device PN	Packing
Part Number G ⁽¹⁾ -WS	Tape&Reel: 3 Kpcs/Reel

Note: (1) RoHS product for packing code suffix "G" ; Halogen free product for packing code suffix "H"

*****Disclaimer*****

WILLAS reserves the right to make changes without notice to any product specification herein, to make corrections, modifications, enhancements or other changes. WILLAS or anyone on its behalf assumes no responsibility or liability for any errors or inaccuracies. Data sheet specifications and its information contained are intended to provide a product description only. "Typical" parameters which may be included on WILLAS data sheets and/ or specifications can and do vary in different applications and actual performance may vary over time. WILLAS does not assume any liability arising out of the application or use of any product or circuit.

WILLAS products are not designed, intended or authorized for use in medical, life-saving implant or other applications intended for life-sustaining or other related applications where a failure or malfunction of component or circuitry may directly or indirectly cause injury or threaten a life without expressed written approval of WILLAS. Customers using or selling WILLAS components for use in such applications do so at their own risk and shall agree to fully indemnify WILLAS Inc and its subsidiaries harmless against all claims, damages and expenditures.