



### SOT-23 Plastic-Encapsulate MOSFETS

P-Channel 20-V(D-S) MOSFET

#### FEATURE

TrenchFET Power MOSFET

#### APPLICATIONS

- Load Switch for Portable Devices
- DC/DC Converter
- **Pb-Free package is available**  
RoHS product for packing code suffix "G"  
Halogen free product for packing code suffix "H"

MARKING: S1

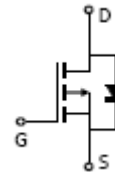
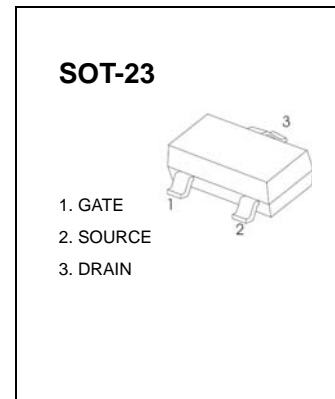

#### Maximum ratings ( $T_a=25^{\circ}\text{C}$ unless otherwise noted)

Parameter	Symbol	Value	Unit
Drain-Source Voltage	$V_{DS}$	-20	V
Gate-Source Voltage	$V_{GS}$	$\pm 8$	
Continuous Drain Current	$I_D$	-2.3	A
Pulsed Drain Current	$I_{DM}$	-10	
Continuous Source-Drain Diode Current	$I_S$	-0.72	
Maximum Power Dissipation	$P_D$	0.35	W
Thermal Resistance from Junction to Ambient( $t \leq 5s$ )	$R_{\theta JA}$	357	$^{\circ}\text{C}/\text{W}$
Junction Temperature	$T_J$	150	$^{\circ}\text{C}$
Storage Temperature	$T_{stg}$	-55 ~+150	



### SOT-23 Plastic-Encapsulate MOSFETS

#### Electrical characteristics (T<sub>a</sub>=25°C unless otherwise noted)

Parameter	Symbol	Test Condition	Min	Typ	Max	Units
<b>Static</b>						
Drain-source breakdown voltage	V <sub>(BR)DSS</sub>	V <sub>GS</sub> = 0V, I <sub>D</sub> = -250μA	-20			V
Gate-source threshold voltage	V <sub>GS(th)</sub>	V <sub>DS</sub> = V <sub>GS</sub> , I <sub>D</sub> = -250μA	-0.4		-1	
Gate-source leakage	I <sub>GSS</sub>	V <sub>DS</sub> = 0V, V <sub>GS</sub> = ±8V			±100	nA
Zero gate voltage drain current	I <sub>DSS</sub>	V <sub>DS</sub> = -20V, V <sub>GS</sub> = 0V			-1	μA
Drain-source on-state resistance <sup>a</sup>	R <sub>DS(on)</sub>	V <sub>GS</sub> = -4.5V, I <sub>D</sub> = -2.8A		0.090	0.112	Ω
		V <sub>GS</sub> = -2.5V, I <sub>D</sub> = -2.0A		0.110	0.142	
Forward transconductance <sup>a</sup>	g <sub>fs</sub>	V <sub>DS</sub> = -5V, I <sub>D</sub> = -2.8A		6.5		S
<b>Dynamic<sup>b</sup></b>						
Input capacitance	C <sub>iss</sub>	V <sub>DS</sub> = -10V, V <sub>GS</sub> = 0V, f = 1MHz		405		pF
Output capacitance	C <sub>oss</sub>			75		
Reverse transfer capacitance	C <sub>rss</sub>			55		
Total gate charge	Q <sub>g</sub>	V <sub>DS</sub> = -10V, V <sub>GS</sub> = -4.5V, I <sub>D</sub> = -3A		5.5	10	nC
				3.3	6	
Gate-source charge	Q <sub>gs</sub>	V <sub>DS</sub> = -10V, V <sub>GS</sub> = -2.5V, I <sub>D</sub> = -3A		0.7		
Gate-drain charge	Q <sub>gd</sub>			1.3		
Gate resistance	R <sub>g</sub>	f = 1MHz		6.0		Ω
Turn-on delay time	t <sub>d(on)</sub>	V <sub>DD</sub> = -10V, R <sub>L</sub> = 10Ω, I <sub>D</sub> = -1A, V <sub>GEN</sub> = -4.5V, R <sub>g</sub> = 1Ω		11	20	ns
Rise time	t <sub>r</sub>			35	60	
Turn-off delay time	t <sub>d(off)</sub>			30	50	
Fall time	t <sub>f</sub>			10	20	
<b>Drain-source body diode characteristics</b>						
Continuous source-drain diode current	I <sub>S</sub>	T <sub>C</sub> = 25°C			-1.3	A
Pulse diode forward current <sup>a</sup>	I <sub>SM</sub>				-10	
Body diode voltage	V <sub>SD</sub>	I <sub>S</sub> = -0.7A		-0.8	-1.2	V

#### Notes :

- a. Pulse Test : Pulse Width < 300μs, Duty Cycle ≤ 2%.
- b. Guaranteed by design, not subject to production testing.



## Typical Characteristics

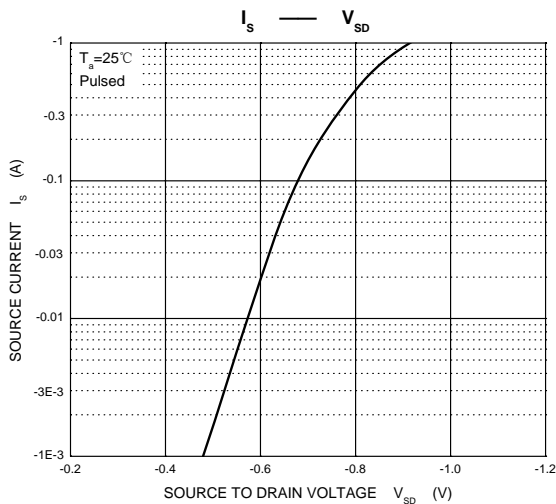
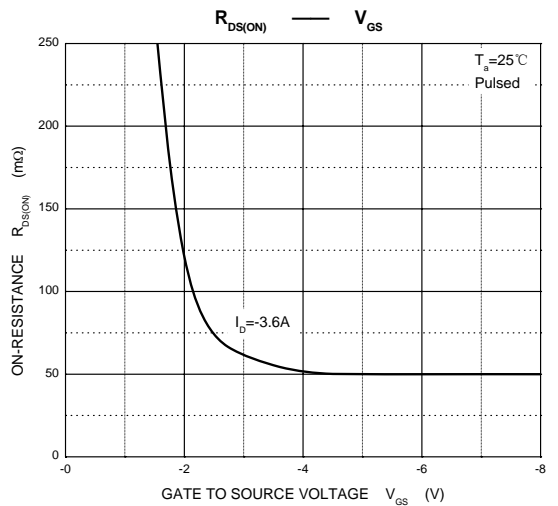
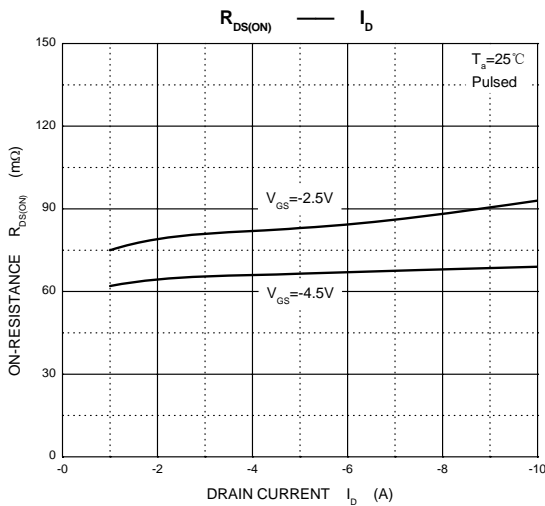
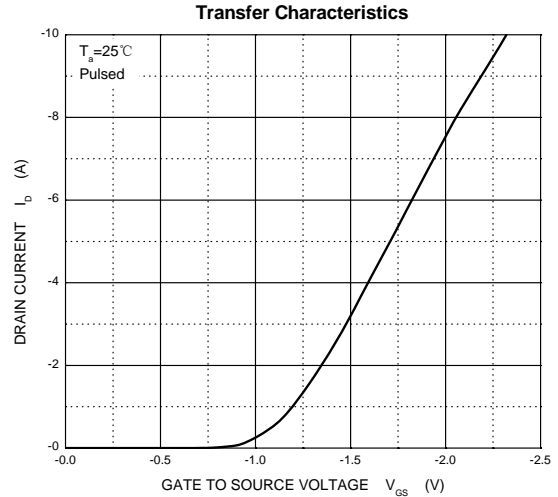
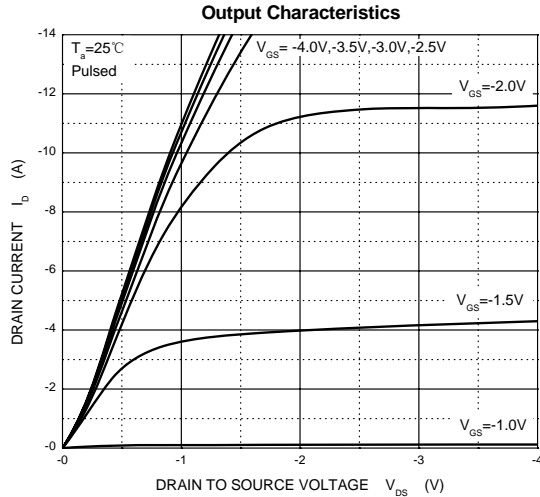



### Outline Drawing

### SOT-23

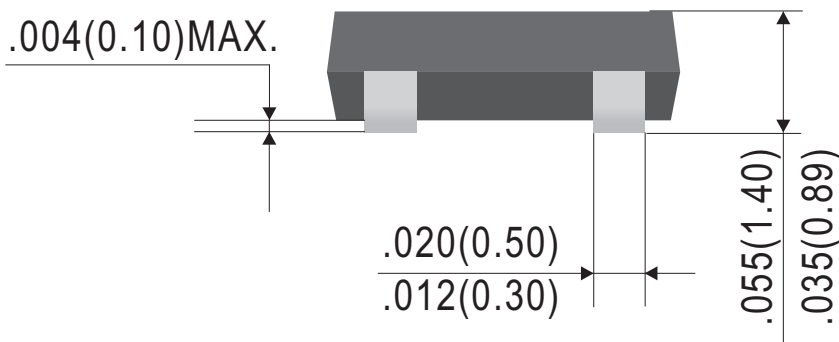
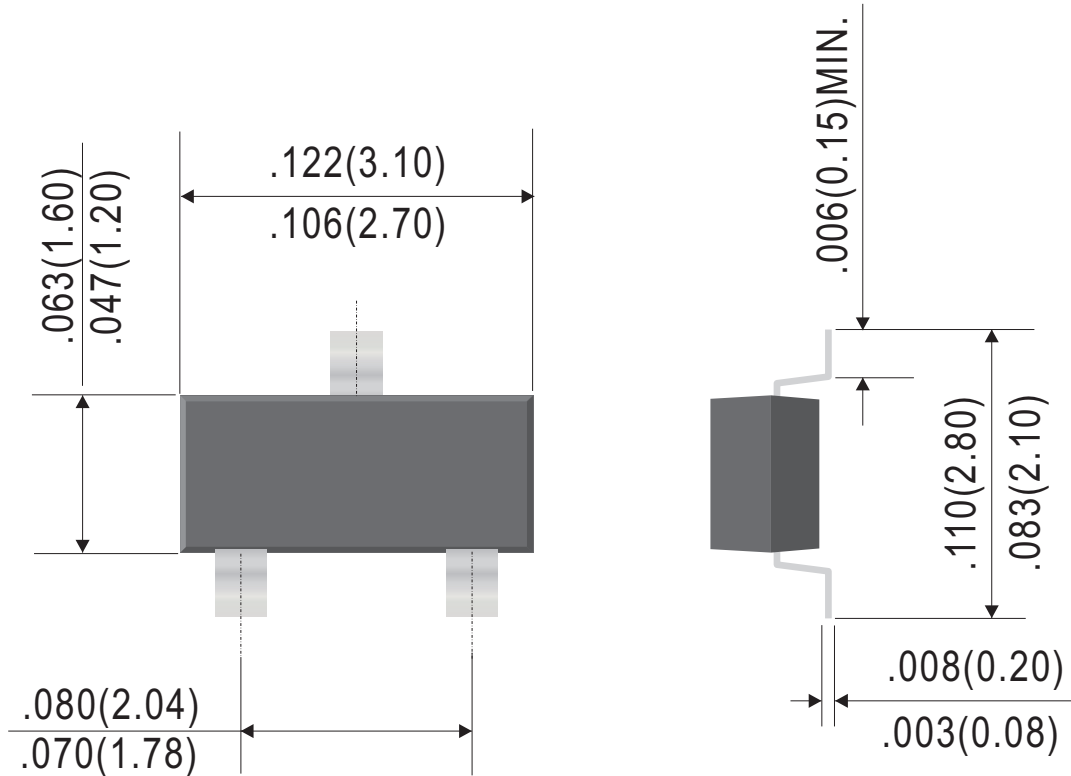

Dimensions in inches and (millimeters)

**SOT-23 Plastic-Encapsulate MOSFETS****Ordering Information:**

Device PN	Packing
SE2301-T <sup>(1)</sup> G <sup>(2)</sup> -WS	Tape&Reel: 3 Kpcs/Reel

Note: (1) Packing code, Tape &amp; Reel

(2) RoHS product for packing code suffix "G" ; Halogen free product for packing code suffix "H"

**\*\*\*Disclaimer\*\*\***

WILLAS reserves the right to make changes without notice to any product specification herein, to make corrections, modifications, enhancements or other changes. WILLAS or anyone on its behalf assumes no responsibility or liability for any errors or inaccuracies. Data sheet specifications and its information contained are intended to provide a product description only. "Typical" parameters which may be included on WILLAS data sheets and/ or specifications can and do vary in different applications and actual performance may vary over time. WILLAS does not assume any liability arising out of the application or use of any product or circuit.

WILLAS products are not designed, intended or authorized for use in medical, life-saving implant or other applications intended for life-sustaining or other related applications where a failure or malfunction of component or circuitry may directly or indirectly cause injury or threaten a life without expressed written approval of WILLAS. Customers using or selling WILLAS components for use in such applications do so at their own risk and shall agree to fully indemnify WILLAS Inc and its subsidiaries harmless against all claims, damages and expenditures.