

■ Features

- Pb-Free package is available.

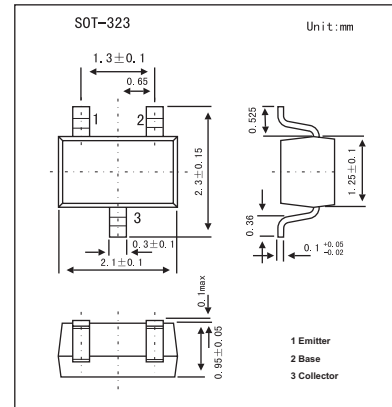
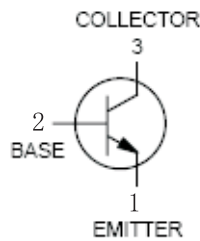

■ Absolute Maximum Ratings Ta = 25°C

Parameter	Symbol	Rating	Unit
Collector-emitter voltage	V _{CEO}	40	V
Collector-base voltage	V _{CBO}	60	V
Emitter-base voltage	V _{EBO}	6	V
Collector current	I _c	200	mA
Total Device Dissipation FR-5 Board	P _D	150	mW
Thermal Resistance, Junction-to-Ambient	R _{θJA}	833	°C/W
Junction temperature	T _j	150	°C
Storage temperature	T _{stg}	-55 to +150	°C

■ Electrical Characteristics Ta = 25°C

Parameter	Symbol	Testconditions	Min	Typ	Max	Unit
Collector-emitter breakdown voltage	V _{(BR)CEO}	I _C = 1.0 mA, I _B = 0	40			V
Collector-base breakdown voltage	V _{(BR)CBO}	I _C = 10 μA, I _E = 0	60			V
Emitter-base breakdown voltage	V _{(BR)EBO}	I _E = 10 μA, I _C = 0	6			V
Base cutoff current	I _{BL}	V _{CE} = 30 V, V _{EB} = 3.0 V			50	nA
Collector cutoff current	I _{CEX}	V _{CE} = 30 V, V _{EB} = 3.0 V			50	nA
DC current gain *	H _{FE}	I _C = 0.1 mA, V _{CE} = 1.0 V	40		300	
		I _C = 1.0 mA, V _{CE} = 1.0 V	70			
		I _C = 10 mA, V _{CE} = 1.0 V	100			
		I _C = 50 mA, V _{CE} = 1.0 V	60			
		I _C = 100 mA, V _{CE} = 1.0 V	30			
Collector-emitter saturation voltage *	V _{CE(sat)}	I _C = 10 mA, I _B = 1.0 mA			0.2	V
		I _C = 50 mA, I _B = 5.0 mA			0.3	
Base-emitter saturation voltage *	V _{BE(sat)}	I _C = 10 mA, I _B = 1.0 mA	0.65		0.85	
		I _C = 50 mA, I _B = 5.0 mA			0.95	
Current-gain-bandwidth product	f _T	I _C = 10 mA, V _{CE} = 20 V, f = 100 MHz	300			MHz
Output capacitance	C _{obo}	V _{CB} = 5.0 V, I _E = 0, f = 1.0 MHz			4	pF
Input capacitance	C _{ibo}	V _{EB} = 0.5 V, I _C = 0, f = 1.0 MHz			8	pF
Input impedance	h _{ie}	V _{CE} = 10 V, I _C = 1.0 mA, f = 1.0 kHz	1.0		10	kΩ
Voltage feedback ratio	h _{re}	V _{CE} = 10 V, I _C = 1.0 mA, f = 1.0 kHz	0.5		8.0	X10 ⁻⁴
Small-signal current gain	h _{fe}	V _{CE} = 10 V, I _C = 1.0 mA, f = 1.0 kHz	100		400	
Output admittance	h _{oe}	V _{CE} = 10 V, I _C = 1.0 mA, f = 1.0 kHz	1.0		40	μmhos
Noise figure	NF	V _{CE} = 5.0 V, I _C = 100 μA, R _S = 1.0 kΩ, f = 1.0 kHz			5	dB
Delay time	t _d	V _{CC} = 3.0 V, V = - 0.5 V			35	ns
Rise time	t _r	I _C = 10 mA, I _{B1} = 1.0 mA			35	ns
Storage time	t _s	V _{CC} = 3.0 V, I _C = 10 mA			200	ns
Fall time	t _f	I _{B1} = I _{B2} = 1.0 mA			50	ns

* Pulse test: pulse width ≤ 300 μs, duty cycle ≤ 2.0%.

■ Marking

Marking	AM
---------	----