

# PZT2907A

■ Features

- Power Collector dissipation:  $P_c=1W$
- Continuous Collector Current:  $I_c=-600mA$

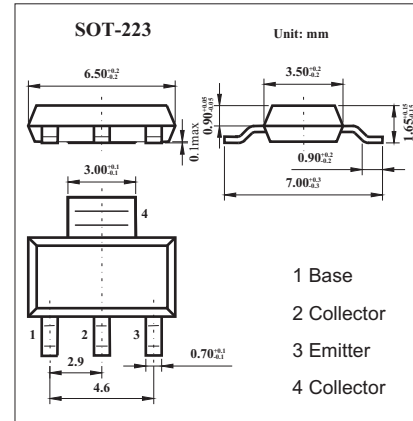

■ Absolute Maximum Ratings  $T_a = 25^\circ C$

Parameter	Symbol	Rating	Unit
Collector-base voltage	$V_{CBO}$	-60	V
Collector-emitter voltage	$V_{CEO}$	-60	V
Emitter-base voltage	$V_{EBO}$	-5	V
Continuous Collector Current	$I_c$	-600	mA
Peak collector current	$I_{CM}$	-800	mA
Power Collector dissipation	$P_c$	1	W
Operating and storage temperature range	$T_j, T_{stg}$	-55 to +150	$^\circ C$

■ Electrical Characteristics  $T_a = 25^\circ C$

Parameter	Symbol	Test conditons	Min	Typ	Max	Unit
Collector-base breakdown voltage	$V_{(BR)CBO}$	$I_c=-10\mu A$	-60			V
Collector-emitter breakdown voltage *	$V_{(BR)CEO}$	$I_c=-10mA$	-60			V
Emitter-base breakdown voltage	$V_{(BR)EBO}$	$I_E=-10\mu A$	-5			V
Collector cutoff current	$I_{CBO}$	$V_{CB}=-50V, I_E=0$			-10	nA
Emitter cut-off current	$I_{EBO}$	$V_{EB}=-5V, I_c=0$			-50	nA
Collector-emitter saturation voltage *	$V_{CE(sat)}$	$I_c=-500mA, I_B=-50mA$			-1.6	V
Base-emitter saturation voltage *	$V_{BE(sat)}$	$I_c=-500mA, I_B=-50mA$			-2.6	V
Base-emitter voltage *	$V_{BE(ON)}$	$I_c=-1A, V_{CE}=-5V$			-1.0	V
DC current gain	$h_{FE}$	$I_c=-1mA, V_{CE}=-5V^*$	300			
		$I_c=-100mA, V_{CE}=-5V$	300		800	
		$I_c=-500mA, V_{CE}=-5V^*$	250			
		$I_c=-1A, V_{CE}=-5V^*$	160			
Transition frequency	$f_T$	$I_c=-50mA, V_{CE}=-20V, f=100MHz$	200			MHz
Output capacitance	$C_{ob}$	$V_{CB}=-10V, I_E=0, f=1MHz$			8	pF

\* Pulse test:  $t_p \leq 300 \mu s; d \leq 0.02$ .

■ Marking

Marking	2907A
---------	-------