

# KCP69

## ■ Features

- High current (max. 1 A)
- Low voltage (max. 20 V).

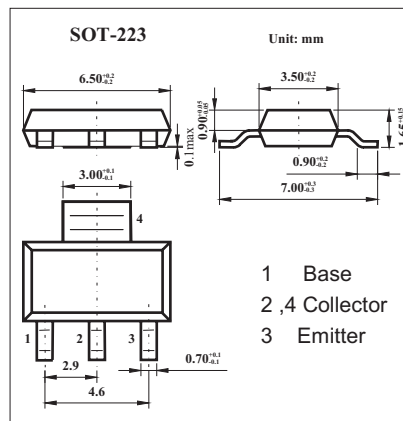
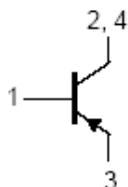

## ■ Absolute Maximum Ratings $T_a = 25^\circ\text{C}$

Parameter	Symbol	Rating	Unit
Collector-base voltage	$V_{CB0}$	-32	V
Collector-emitter voltage	$V_{CE0}$	-20	V
Emitter-base voltage	$V_{EB0}$	-5	V
Collector current (DC)	$I_C$	-1	A
Peak collector current	$I_{CM}$	-2	A
Peak base current	$I_{BM}$	-200	mA
Total power dissipation $T_{amb} \leq 25^\circ\text{C}$	$P_D$	1.35	W
Storage temperature	$T_{stg}$	-65 to +150	$^\circ\text{C}$
Junction temperature	$T_j$	150	$^\circ\text{C}$
Operating ambient temperature	$T_{amb}$	-65 to +150	$^\circ\text{C}$
Thermal resistance from junction to ambient	$R_{th(j-a)}$	91	K/W
Thermal resistance from junction to solder point	$R_{th(j-s)}$	10	K/W

## ■ Electrical Characteristics $T_a = 25^\circ\text{C}$

Parameter	Symbol	Testconditons	Min	Typ	Max	Unit
Collector cutoff current	$I_{CBO}$	$I_E = 0\text{ A}; V_{CB} = -25\text{ V}$			-100	nA
		$I_E = 0\text{ A}; V_{CB} = -25\text{ V}; T_j = 150^\circ\text{C}$			-10	$\mu\text{A}$
Emitter cutoff current	$I_{EBO}$	$I_C = 0\text{ A}; V_{EB} = -5\text{ V}$			-100	nA
DC current gain	$h_{FE}$	$V_{CE} = -10\text{ V}; I_C = -5\text{ mA}$	50			
		$V_{CE} = -1\text{ V}; I_C = -500\text{ mA}$	85		375	
		$V_{CE} = -1\text{ V}; I_C = -1\text{ A}$	60			
DC current gain	BCP69-16 BCP69-25	$V_{CE} = -1\text{ V}; I_C = -500\text{ mA}$	100		250	
			160		375	
Collector-emitter saturation voltage	$V_{CEsat}$	$I_C = -1\text{ A}; I_B = -100\text{ mA};$			-500	mV
Base-emitter voltage	$V_{BE}$	$V_{CE} = -10\text{ V}; I_C = -5\text{ mA}$		-620		mV
		$V_{CE} = -1\text{ V}; I_C = -1\text{ A}$			-1	V
Collector capacitance	$C_c$	$I_E = I_C = 0\text{ A}; V_{CB} = -5\text{ V}; f = 1\text{ MHz}$		48		pF
Transition frequency	$f_T$	$I_C = -10\text{ mA}; V_{CE} = -5\text{ V}; f = 100\text{ MHz}$	40			MHz

## ■ Marking

Marking	BCP69
---------	-------



■ Typical Characteristics

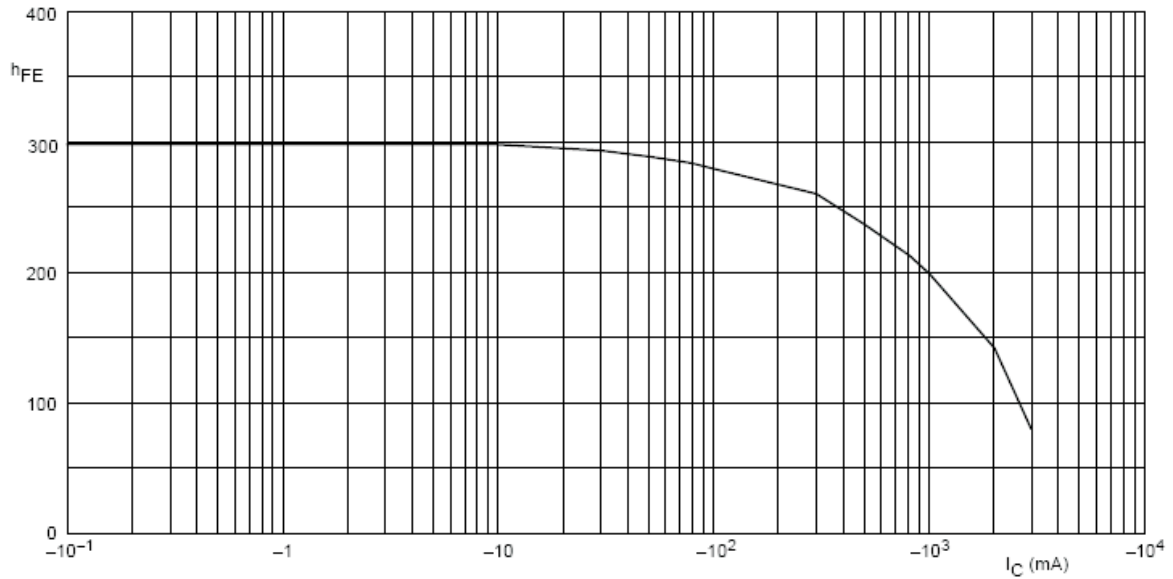

$V_{CE} = -1$  V.

Fig.1 DC current gain; typical values.