

## 2SC4523

### ■ Features

- Large current capacity.
- Low collector-to-emitter saturation voltage.
- Fast switching speed.

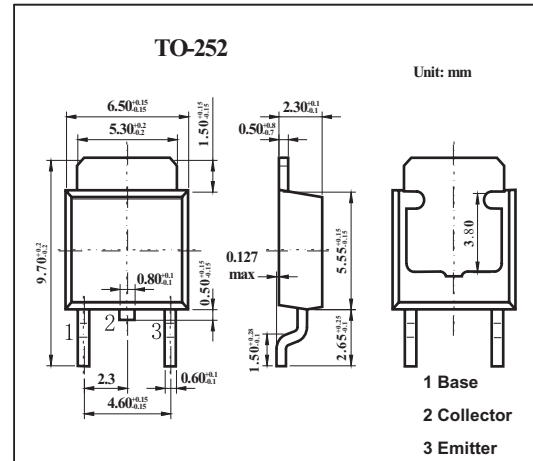

### ■ Absolute Maximum Ratings $T_a = 25^\circ\text{C}$

Parameter	Symbol	Rating	Unit
Collector-base voltage	$V_{CB0}$	60	V
Collector-emitter voltage	$V_{CE0}$	45	V
Emitter-base voltage	$V_{EB0}$	5	V
Collector current	$I_C$	8	A
Collector current (pulse)	$I_{CP}$	12	A
Collector dissipation	$P_C$	1	W
Junction temperature	$T_j$	150	$^\circ\text{C}$
Storage temperature	$T_{stg}$	-55 to +150	$^\circ\text{C}$

**2SC4523**

■ Electrical Characteristics Ta = 25°C

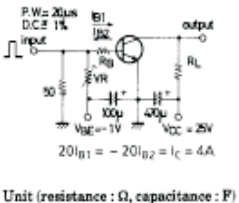
Parameter	Symbol	Testconditons	Min	Typ	Max	Unit	
Collector cutoff current	ICBO	V <sub>CB</sub> = 45V, I <sub>E</sub> =0			1	μA	
Emitter cutoff current	IEBO	V <sub>EB</sub> = 2V, I <sub>C</sub> =0			10	μA	
DC current gain	h <sub>FE</sub>	V <sub>CE</sub> = 2V, I <sub>C</sub> = 500mA	100		400		
		V <sub>CE</sub> = 2V, I <sub>C</sub> = 8A	40				
Gain bandwidth product	f <sub>T</sub>	V <sub>CE</sub> = 2V, I <sub>C</sub> = 500mA		250		MHz	
Output capacitance	C <sub>ob</sub>	V <sub>CB</sub> = 10V, f = 1.0MHz		65		pF	
Collector-emitter saturation voltage	V <sub>CE(sat)</sub>	I <sub>C</sub> = 4A, I <sub>B</sub> = 200mA		0.25	0.7	V	
Base-emitter saturation voltage	V <sub>BE(sat)</sub>	I <sub>C</sub> = 4A, I <sub>B</sub> = 200mA		0.95	1.3	V	
Collector-base breakdown voltage	V <sub>(BR)CBO</sub>	I <sub>C</sub> = 100μA, I <sub>E</sub> = 0	60			V	
Collector-emitter breakdown voltage	V <sub>(BR)CEO</sub>	I <sub>C</sub> = 1mA, R <sub>BE</sub> = ∞	45			V	
Emitter-base breakdown voltage	V <sub>(BR)EBO</sub>	I <sub>E</sub> = 100μA, I <sub>C</sub> = 0	5			V	
Turn-on time	t <sub>on</sub>			50	100	ns	
Storage time	t <sub>stg</sub>				150	270	ns
Fall time	t <sub>f</sub>				180	350	ns

■ hFE Classification

Rank	R	S	T
hFE	100~200	140~280	200~400