

## Silicon PNP Power Transistors

MJ15027

## DESCRIPTION

- With TO-3 package
- Complement to type MJ15026
- Excellent safe operating area

## APPLICATIONS

- For high power audio ,stepping motor and other linear applications
- Relay or solenoid drivers
- DC-DC converters inverters

## PINNING(see Fig.2)

PIN	DESCRIPTION
1	Base
2	Emitter
3	Collector

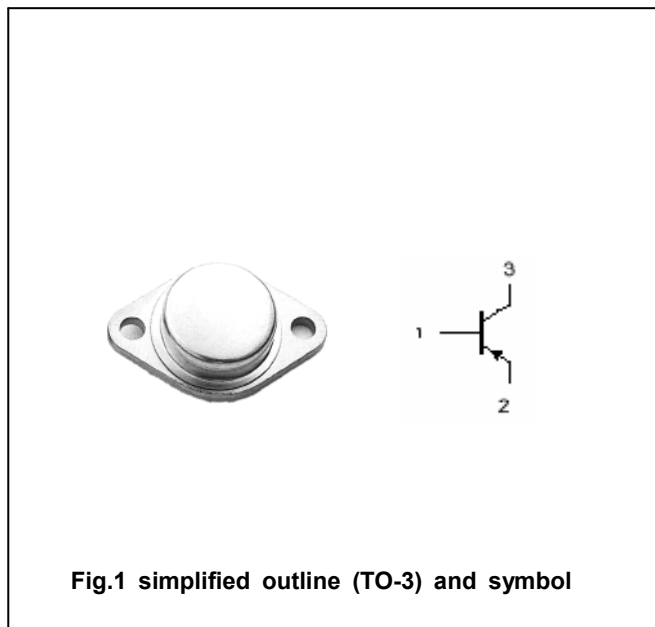

Fig.1 simplified outline (TO-3) and symbol

ABSOLUTE MAXIMUM RATINGS( $T_C=25^\circ\text{C}$ )

SYMBOL	PARAMETER	CONDITIONS	VALUE	UNIT
$V_{CBO}$	Collector-base voltage	Open emitter	-200	V
$V_{CEO}$	Collector-emitter voltage	Open base	-200	V
$V_{EBO}$	Emitter-base voltage	Open collector	-7	V
$I_C$	Collector current		-15	A
$I_B$	Base current		-7	A
$P_C$	Collector power dissipation	$T_C=25^\circ\text{C}$	250	W
$T_j$	Junction temperature		175	$^\circ\text{C}$
$T_{stg}$	Storage temperature		-65~175	$^\circ\text{C}$

## THERMAL CHARACTERISTICS

SYMBOL	PARAMETER	MAX	UNIT
$R_{th\ j-c}$	Thermal resistance junction to case	0.98	$^\circ\text{C}/\text{W}$

## Silicon PNP Power Transistors

## MJ15027

## CHARACTERISTICS

T<sub>j</sub>=25 °C unless otherwise specified

SYMBOL	PARAMETER	CONDITIONS	MIN	TYP.	MAX	UNIT
V <sub>(BR)CEO</sub>	Collector-emitter breakdown voltage	I <sub>C</sub> =-50mA ; I <sub>B</sub> =0	-200			V
V <sub>(BR)EBO</sub>	Emitter-base breakdown voltage	I <sub>E</sub> =-1mA ; I <sub>C</sub> =0	-7			V
V <sub>CE(sat)</sub>	Collector-emitter saturation voltage	I <sub>C</sub> =-10A; I <sub>B</sub> =-1A			-2.0	V
V <sub>BE</sub>	Base-emitter on voltage	I <sub>C</sub> =-5A ; V <sub>CE</sub> =-5V			-1.5	V
I <sub>CBO</sub>	Collector cut-off current	V <sub>CB</sub> =-200V; I <sub>E</sub> =0			-0.1	mA
I <sub>EBO</sub>	Emitter cut-off current	V <sub>EB</sub> =-7V; I <sub>C</sub> =0			-0.1	mA
h <sub>FE</sub>	DC current gain	I <sub>C</sub> =-5A ; V <sub>CE</sub> =-5V	25		150	
f <sub>T</sub>	Transition frequency	I <sub>C</sub> =-0.5A ; V <sub>CE</sub> =-12V	15			MHz

PACKAGE OUTLINE

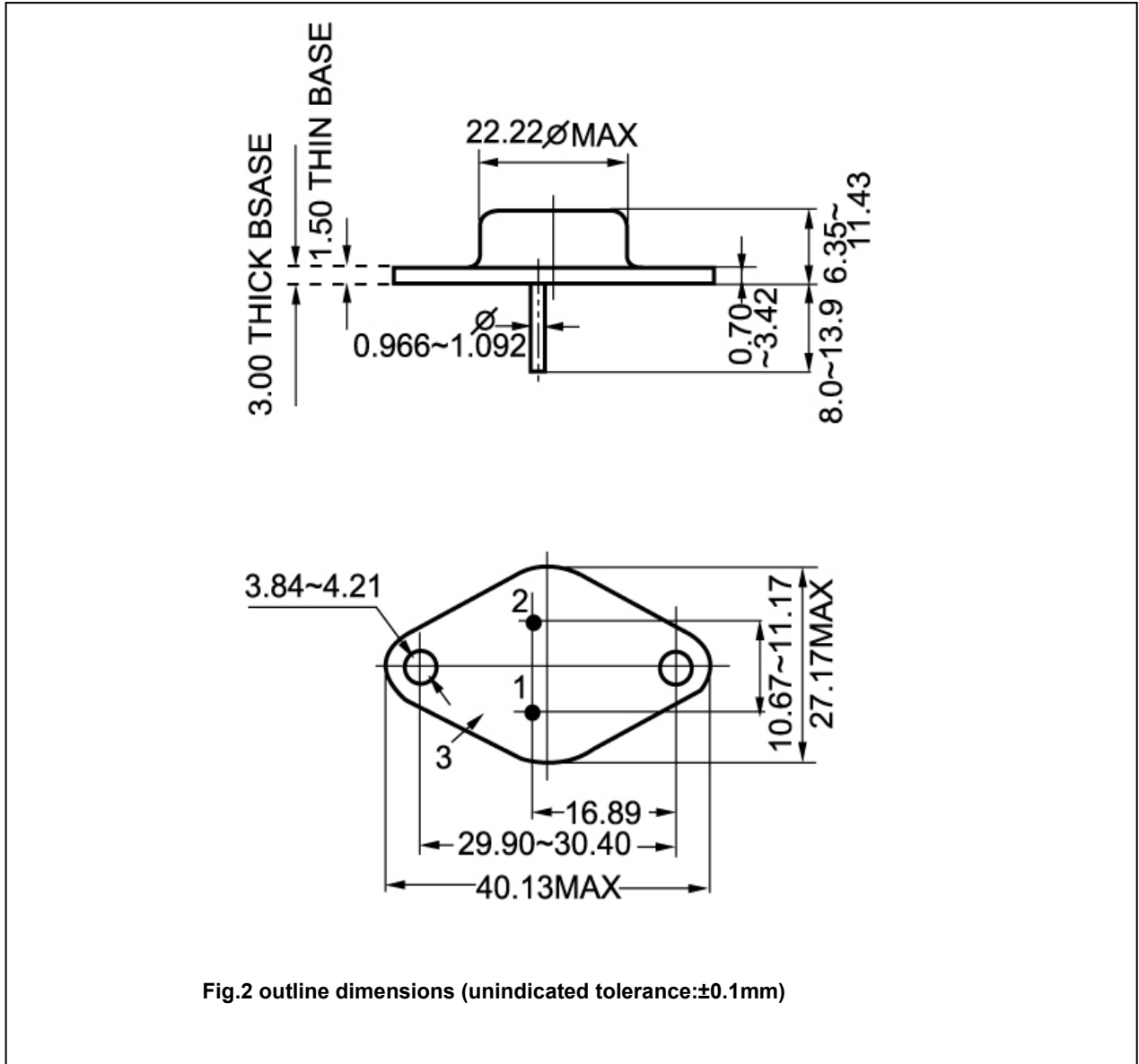

Fig.2 outline dimensions (unindicated tolerance:±0.1mm)