

Silicon NPN Power Transistors

2SD1196

DESCRIPTION

- With TO-220 package
- High DC current gain.
- High current capacity and wide ASO.
- Low saturation voltage
- DARLINGTON

APPLICATIONS

- Motor drivers, printer hammer drivers, relay drivers,voltage regulator control.

PINNING

PIN	DESCRIPTION
1	Base
2	Collector;connected to mounting base
3	Emitter

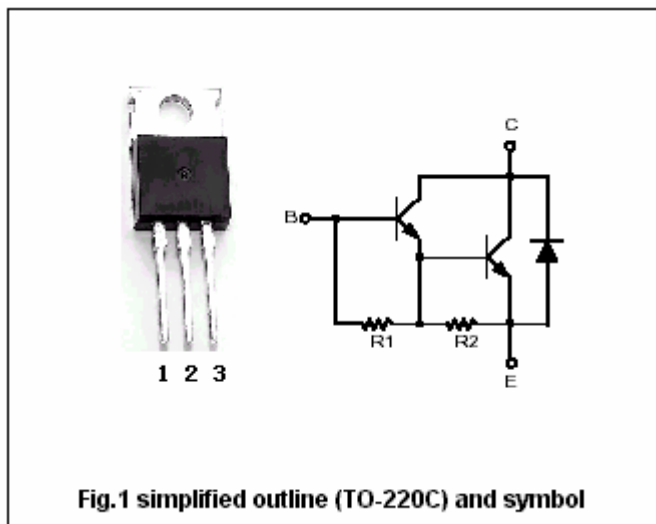

Absolute maximum ratings (Ta=25°C)

SYMBOL	PARAMETER	CONDITIONS	VALUE	UNIT
V _{CBO}	Collector-base voltage	Open emitter	110	V
V _{CEO}	Collector-emitter voltage	Open base	100	V
V _{EBO}	Emitter-base voltage	Open collector	6	V
I _C	Collector current		8	A
I _{CM}	Collector current-peak		12	A
P _C	Collector power dissipation		1.75	W
		T _C =25°C	40	
T _j	Junction temperature		150	°C
T _{stg}	Storage temperature		-55~150	°C

Silicon NPN Power Transistors

2SD1196

CHARACTERISTICS

T_j=25°C unless otherwise specified

SYMBOL	PARAMETER	CONDITIONS	MIN	TYP	MAX	UNIT
V _{(BR)CBO}	Collector-base breakdown voltage	I _C =5mA ; I _E =0	110			V
V _{(BR)CEO}	Collector-emitter breakdown voltage	I _C =50mA ; R _{BE} =∞	100			V
V _{CEsat}	Collector-emitter saturation voltage	I _C =4A, I _B =8mA		0.9	1.5	V
V _{BEsat}	Base-emitter saturation voltage	I _C =4A, I _B =8mA			2.0	V
I _{CBO}	Collector cut-offcurrent	V _{CB} =80V; I _E =0			0.1	mA
I _{EBO}	Emitter cut-offcurrent	V _{EB} =5V; I _C =0			3.0	mA
h _{FE}	DC current gain	I _C =4A ; V _{CE} =3V	1500	4000		
f _T	Transition frequency	I _C =4A ; V _{CE} =5V		20		MHz

Switching times

t _{on}	Turn-on time	I _C =500I _{B1} =-500I _{B2} =4A V _{CC} =50V; R _L =12.5Ω;		0.6		μs
t _{stg}	Storage time			4.8		μs
t _f	Fall time			1.6		μs

PACKAGE OUTLINE

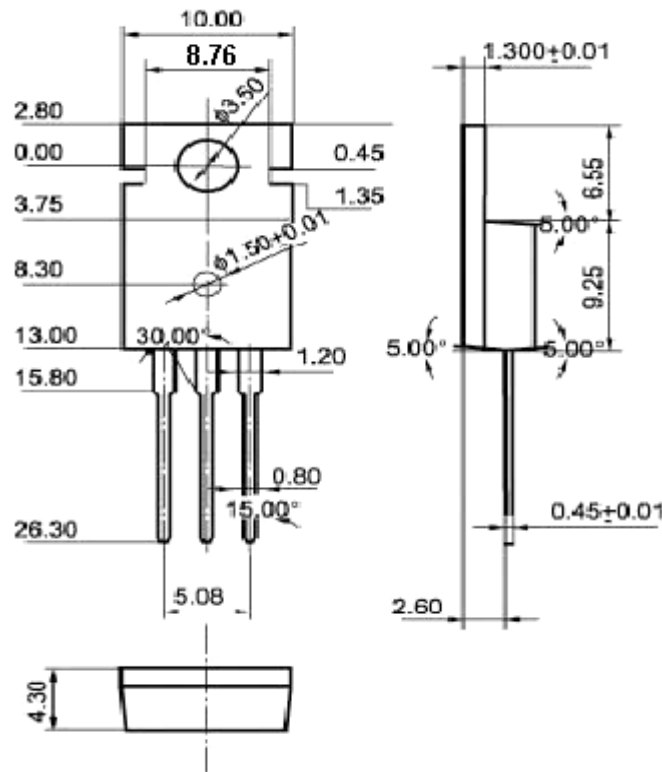

Fig.2 outline dimensions (unindicated tolerance:±0.10 mm)