

Silicon NPN Power Transistors

2SD1193

DESCRIPTION

- With TO-3PN package
- Complement to type 2SB883
- High DC current gain
- High current capacity and wide ASO
- Low saturation voltage

APPLICATIONS

- Motor drivers, printer hammer drivers, relay drivers, voltage regulator control.

PINNING

PIN	DESCRIPTION
1	Base
2	Collector;connected to mounting base
3	Emitter

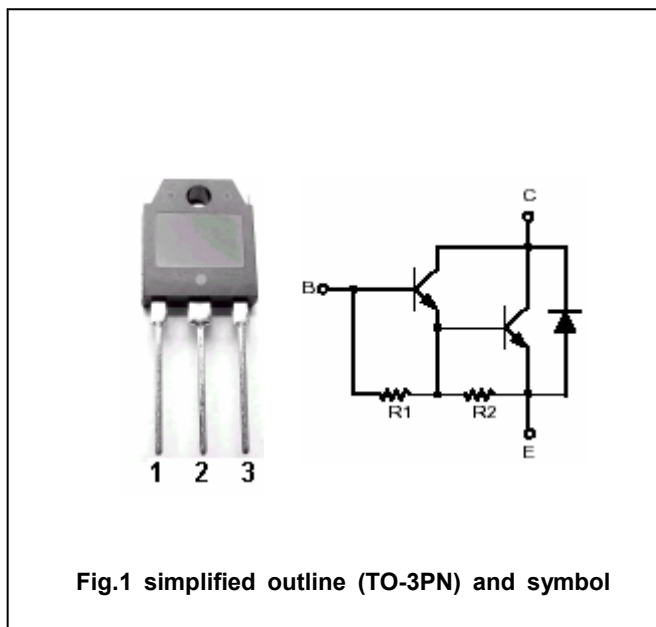

Fig.1 simplified outline (TO-3PN) and symbol

Absolute maximum ratings (Ta=25°C)

SYMBOL	PARAMETER	CONDITIONS	MAX	UNIT
V _{CBO}	Collector-base voltage	Open emitter	70	V
V _{CEO}	Collector-emitter voltage	Open base	60	V
V _{EBO}	Emitter-base voltage	Open collector	6	V
I _C	Collector current (DC)		15	A
I _{CP}	Collector current (Pulse)		20	A
P _C	Collector power dissipation	T _C =25°C	70	W
T _j	Junction temperature		150	°C
T _{stg}	Storage temperature		-55~150	°C

Silicon NPN Power Transistors

2SD1193

CHARACTERISTICS

T_j=25°C unless otherwise specified

SYMBOL	PARAMETER	CONDITIONS	MIN	TYP.	MAX	UNIT
V _{(BR)CEO}	Collector-emitter breakdown voltage	I _C =50mA ; R _{BE} =∞	60			V
V _{(BR)CBO}	Collector-base breakdown voltage	I _C =5mA ; I _E =0	70			V
V _{CEsat}	Collector-emitter saturation voltage	I _C =7A ; I _B =14mA			1.5	V
V _{BEsat}	Base-emitter saturation voltage	I _C =7A ; I _B =14mA			2.0	V
I _{CBO}	Collector cut-off current	V _{CB} =40V ; I _E =0			0.1	mA
I _{EBO}	Emitter cut-off current	V _{EB} =5V ; I _C =0			3	mA
h _{FE}	DC current gain	I _C =7A ; V _{CE} =2V	2000			
f _T	Transition frequency	I _C =7A ; V _{CE} =5V		20		MHz

Silicon NPN Power Transistors

2SD1193

PACKAGE OUTLINE

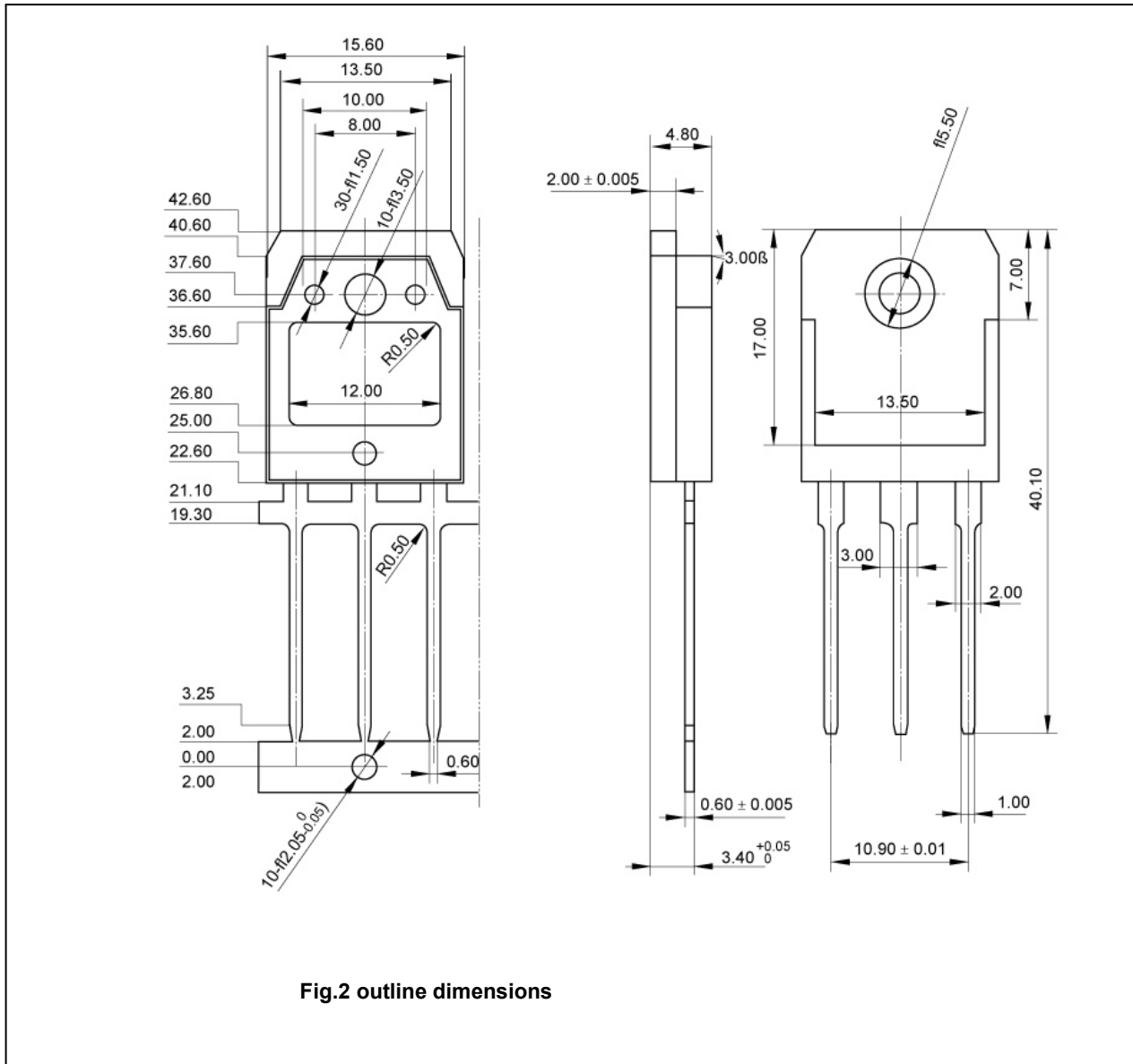

Fig.2 outline dimensions