

Silicon NPN Power Transistors

2SC5271

**DESCRIPTION**

·With TO-220F package

**APPLICATIONS**

·For resonant switching regulator and general purpose applications

**PINNING**

PIN	DESCRIPTION
1	Base
2	Collector
3	Emitter

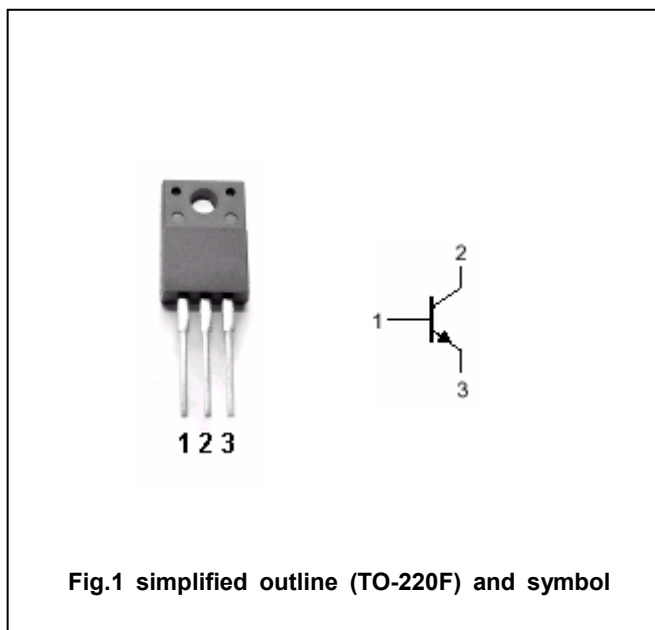

**Absolute maximum ratings(Ta=25°C)**

SYMBOL	PARAMETER	CONDITIONS	VALUE	UNIT
V <sub>CBO</sub>	Collector-base voltage	Open emitter	300	V
V <sub>CEO</sub>	Collector-emitter voltage	Open base	200	V
V <sub>EBO</sub>	Emitter-base voltage	Open collector	7	V
I <sub>C</sub>	Collector current		5	A
I <sub>CM</sub>	Collector current-peak		10	A
I <sub>B</sub>	Base current		2	A
P <sub>C</sub>	Collector power dissipation	T <sub>C</sub> =25°C	30	W
T <sub>j</sub>	Junction temperature		150	°C
T <sub>stg</sub>	Storage temperature		-55~150	°C

## Silicon NPN Power Transistors

## 2SC5271

## CHARACTERISTICS

T<sub>j</sub>=25°C unless otherwise specified

SYMBOL	PARAMETER	CONDITIONS	MIN	TYP.	MAX	UNIT
V <sub>(BR)CEO</sub>	Collector-emitter breakdown voltage	I <sub>C</sub> =10mA; I <sub>B</sub> =0	200			V
V <sub>CEsat</sub>	Collector-emitter saturation voltage	I <sub>C</sub> =2.5A; I <sub>B</sub> =0.5A			1.0	V
V <sub>BEsat</sub>	Base-emitter saturation voltage	I <sub>C</sub> =2.5A; I <sub>B</sub> =0.5A			1.5	V
I <sub>CBO</sub>	Collector cut-off current	V <sub>CB</sub> =300V; I <sub>E</sub> =0			100	μA
I <sub>EBO</sub>	Emitter cut-off current	V <sub>EB</sub> =7V; I <sub>C</sub> =0			100	μA
h <sub>FE-1</sub>	DC current gain	I <sub>C</sub> =2.5A; V <sub>CE</sub> =2V	10		30	
h <sub>FE-2</sub>	DC current gain	I <sub>C</sub> =1mA; V <sub>CE</sub> =2V	15			
f <sub>T</sub>	Transition frequency	I <sub>E</sub> =-0.5A; V <sub>CE</sub> =12V		10		MHz
C <sub>OB</sub>	Output capacitance	V <sub>CB</sub> =10V; f=1MHz		45		pF

## Switching times

t <sub>on</sub>	Turn-on time	I <sub>C</sub> =2.5A; I <sub>B1</sub> =0.5A; I <sub>B2</sub> =-1.0A R <sub>L</sub> =60Ω; V <sub>CC</sub> =150V			0.3	μs
t <sub>stg</sub>	Storage time				1.0	μs
t <sub>f</sub>	Fall time				0.1	μs

Silicon NPN Power Transistors

2SC5271

PACKAGE OUTLINE

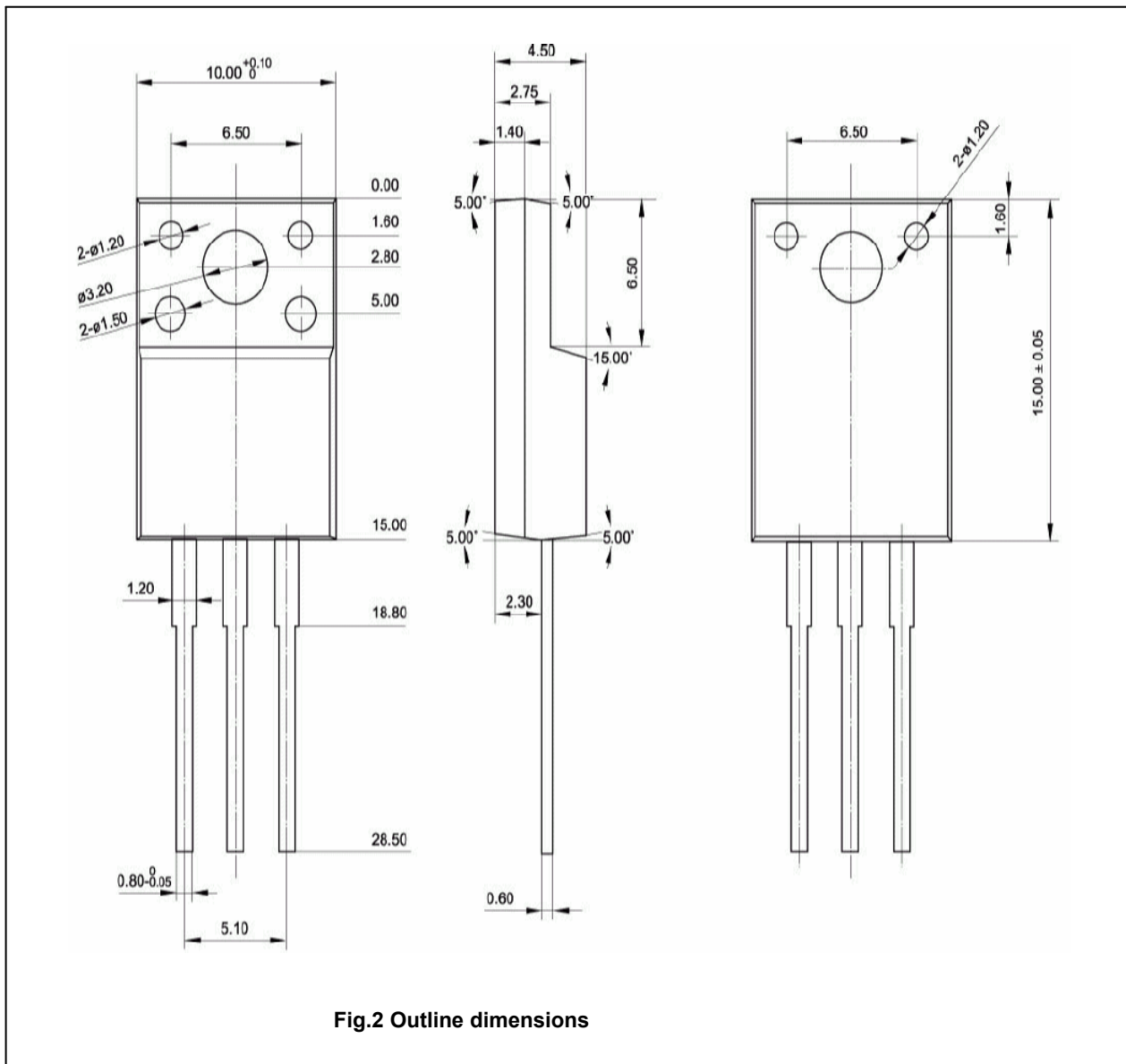

Fig.2 Outline dimensions