

Silicon PNP Power Transistors

2SB1005

DESCRIPTION

- With TO-220C package
- High DC Current Gain
- DARLINGTON

APPLICATIONS

- For audio frequency power amplifier applications

PINNING

PIN	DESCRIPTION
1	Base
2	Collector; connected to mounting base
3	Emitter

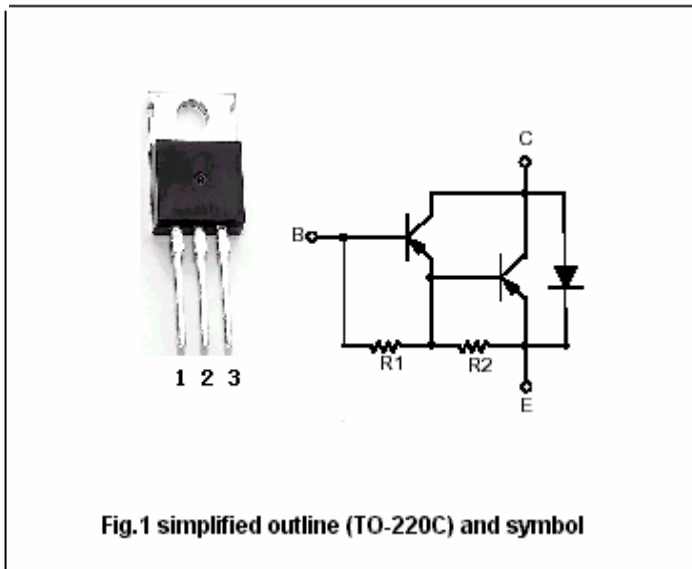

Fig.1 simplified outline (TO-220C) and symbol

Absolute maximum ratings(Ta=25°C)

SYMBOL	PARAMETER	CONDITIONS	VALUE	UNIT
V _{CBO}	Collector-base voltage	Open emitter	-50	V
V _{CEO}	Collector-emitter voltage	Open base	-50	V
V _{EBO}	Emitter-base voltage	Open collector	-5	V
I _C	Collector current-DC		-4	A
P _C	Collector power dissipation	T _C =25°C	30	W
T _j	Junction temperature		150	°C
T _{stg}	Storage temperature		-55~150	°C

Silicon PNP Power Transistors

2SB1005

CHARACTERISTICS

T_j=25 °C unless otherwise specified

SYMBOL	PARAMETER	CONDITIONS	MIN	TYP.	MAX	UNIT
V _{(BR)CEO}	Collector-emitter breakdown voltage	I _C =-30mA, I _B =0	-50			V
V _{(BR)CBO}	Collector-base breakdown voltage	I _C =-1mA, I _E =0	-50			V
V _{CEsat}	Collector-emitter saturation voltage	I _C =-1.5A, I _B =-30mA			-2.5	V
V _{CEsat}	Collector-emitter saturation voltage	I _C =-4A, I _B =-40mA			-4.0	V
I _{CBO}	Collector cut-off current	V _{CB} =-50V, I _E =0			-0.1	mA
I _{EBO}	Emitter cut-off current	V _{EB} =-5V, I _C =0			-2.0	mA
h _{FE-1}	DC current gain	I _C =-1.5A; V _{CE} =-3V	750			
h _{FE-2}	DC current gain	I _C =-4A; V _{CE} =-3V	100			
V _F	Diode forward voltage	I _F =-4A			3.5	V

Silicon PNP Power Transistors

2SB1005

PACKAGE OUTLINE

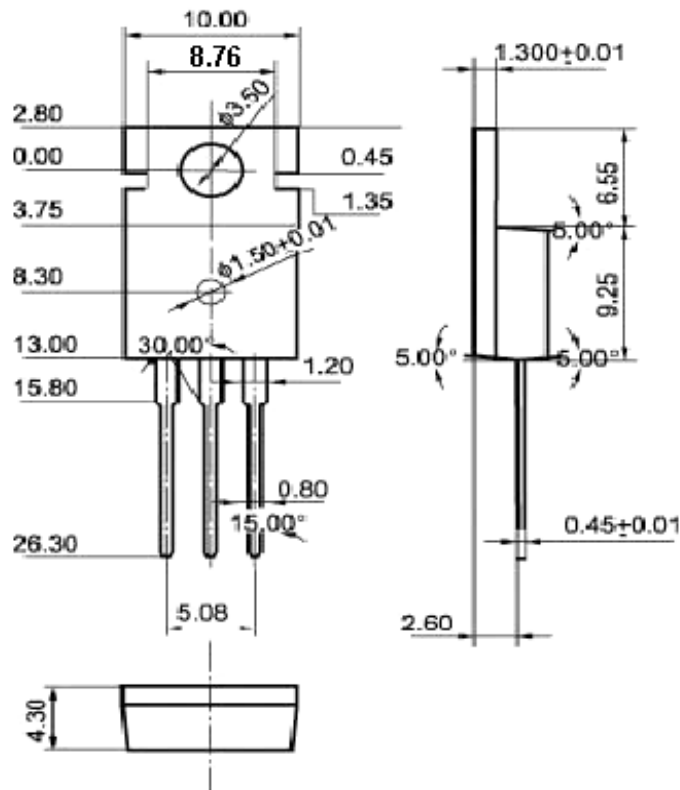

Fig.2 Outline dimensions