

## Silicon PNP Power Transistors

2SA971

## DESCRIPTION

- With TO-3 package
- Excellent safe operating area

## APPLICATIONS

- For high power audio ,stepping motor and other linear applications
- Relay or solenoid drivers
- DC-DC converters inverters

## PINNING(see Fig.2)

PIN	DESCRIPTION
1	Base
2	Emitter
3	Collector

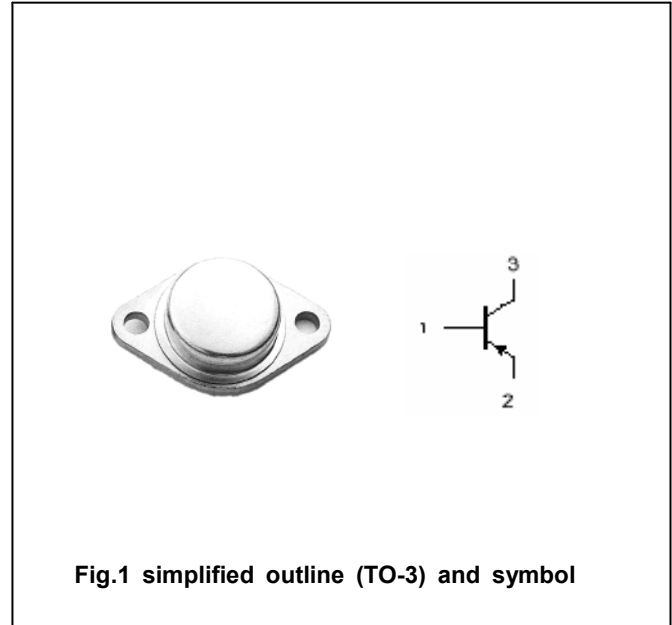
Absolute maximum ratings( $T_a = \square$ )

SYMBOL	PARAMETER	CONDITIONS	VALUE	UNIT
$V_{CBO}$	Collector-base voltage	Open emitter	-150	V
$V_{CEO}$	Collector-emitter voltage	Open base	-150	V
$V_{EBO}$	Emitter-base voltage	Open collector	-6	V
$I_C$	Collector current		-15	A
$I_B$	Base current		-5	A
$P_C$	Collector power dissipation	$T_c = 25 \square$	150	W
$T_j$	Junction temperature		150	$\square$
$T_{stg}$	Storage temperature		-65~200	$\square$

## THERMAL CHARACTERISTICS

SYMBOL	PARAMETER	MAX	UNIT
$R_{th\ j-c}$	Thermal resistance junction to case	0.98	$\square/W$

## Silicon PNP Power Transistors

## 2SA971

## CHARACTERISTICS

T<sub>j</sub>=25 °C unless otherwise specified

SYMBOL	PARAMETER	CONDITIONS	MIN	TYP.	MAX	UNIT
V <sub>(BR)CEO</sub>	Collector-emitter breakdown voltage	I <sub>C</sub> =-50mA ; I <sub>B</sub> =0	-150			V
V <sub>(BR)CBO</sub>	Collector-base breakdown voltage	I <sub>C</sub> =-1mA ; I <sub>E</sub> =0	-150			V
V <sub>(BR)EBO</sub>	Emitter-base breakdown voltage	I <sub>E</sub> =-1mA ; I <sub>C</sub> =0	-6			V
V <sub>CEsat</sub>	Collector-emitter saturation voltage	I <sub>C</sub> =-10A ; I <sub>B</sub> =-1A			-3.0	V
I <sub>CBO</sub>	Collector cut-off current	V <sub>CB</sub> =-150V ; I <sub>E</sub> =0			-0.1	mA
I <sub>EBO</sub>	Emitter cut-off current	V <sub>EB</sub> =-6V ; I <sub>C</sub> =0			-0.1	mA
h <sub>FE</sub>	DC current gain	I <sub>C</sub> =-5A ; V <sub>CE</sub> =-4V	30			
C <sub>OB</sub>	Collector output capacitance	I <sub>E</sub> =0 ; V <sub>CB</sub> =-10V ; f=1MHz		270		pF
f <sub>T</sub>	Transition frequency	I <sub>C</sub> =-0.5A ; V <sub>CE</sub> =-10V		10		MHz

PACKAGE OUTLINE

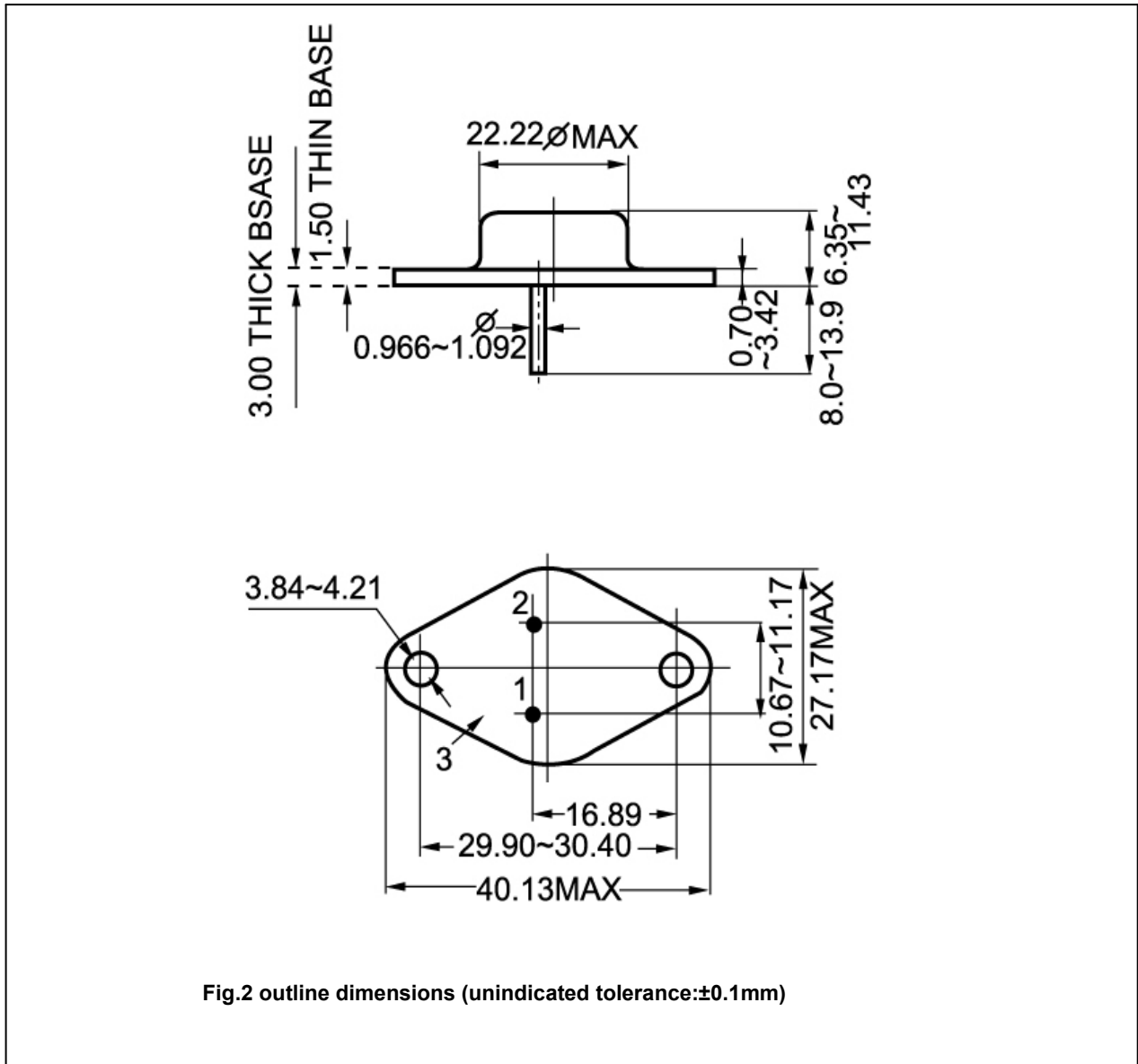

Fig.2 outline dimensions (unindicated tolerance:±0.1mm)