

2SK3019 N-channel MOSFET

FEATURES

- Low on-resistance
- Fast switching speed
- Low voltage drive makes this device ideal for portable equipment
- Easily designed drive circuits
- Easy to parallel

Marking: KN

MOSFET MAXIMUM RATINGS (Ta = 25°C unless otherwise noted)

Symbol	Parameter	Value	Units
V _{DS}	Drain-Source Voltage	30	V
V _{GSS}	Gate-Source Voltage	±20	V
I _D	Continuous Drain Current	0.1	A
R _{θJA}	Thermal Resistance, Junction-to-Ambient	833	°C /W
P _D	Power Dissipation	0.15	W
T _J	Junction Temperature	150	°C
T _{stg}	Storage Temperature	-55~+150	°C

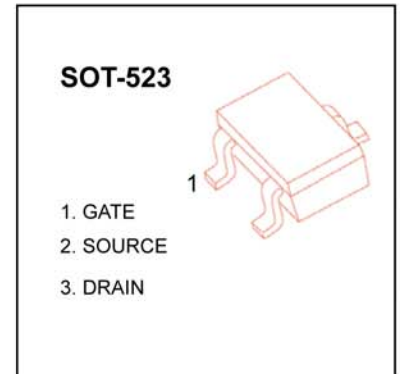

Equivalent circuit

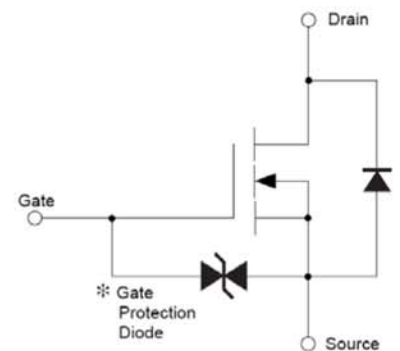

MOSFET ELECTRICAL CHARACTERISTICS (Ta=25°C unless otherwise specified)

Parameter	Symbol	Test Condition	Min	Typ	Max	Units
Off Characteristics						
Drain-Source Breakdown Voltage	V _{DS}	V _{GS} = 0V, I _D = 10μA	30			V
Zero Gate Voltage Drain Current	I _{DSS}	V _{DS} = 30V, V _{GS} = 0V			1	μA
Gate -Source leakage current	I _{GSS}	V _{GS} = ±20V, V _{DS} = 0V			±1	μA
Gate Threshold Voltage	V _{GS(th)}	V _{DS} = 3V, I _D = 100μA	0.8		1.5	V
Drain-Source On-Resistance	R _{DS(on)}	V _{GS} = 4V, I _D = 10mA			8	Ω
		V _{GS} = 2.5V, I _D = 1mA			13	Ω
Forward Transconductance	g _{FS}	V _{DS} = 3V, I _D = 10mA	20			mS
Dynamic Characteristics*						
Input Capacitance	C _{iss}	V _{DS} = 5V, V _{GS} = 0V, f = 1MHz		13		pF
Output Capacitance	C _{oss}			9		pF
Reverse Transfer Capacitance	C _{rss}			4		pF
Switching Characteristics*						
Turn-On Delay Time	t _{d(on)}	V _{GS} = 5V, V _{DD} = 5V, I _D = 10mA, R _g = 10Ω, R _L = 500Ω,		15		ns
Rise Time	t _r			35		ns
Turn-Off Delay Time	t _{d(off)}			80		ns
Fall Time	t _f			80		ns

* These parameters have no way to verify.

Typical Characteristics

2SK3019

