

Single P-channel MOSFET

ELM5K8473A-S

■ General description

ELM5K8473A-S uses advanced trench technology to provide excellent $R_{ds(on)}$, low gate charge and low gate resistance.

■ Features

- $V_{ds} = -60V$
- $I_d = -4.8A$
- $R_{ds(on)} = 135m\Omega$ ($V_{gs} = -10V$)
- $R_{ds(on)} = 155m\Omega$ ($V_{gs} = -4.5V$)

■ Maximum absolute ratings

Parameter	Symbol	Limit	Unit	
Drain-source voltage	V_{ds}	-60	V	
Gate-source voltage	V_{gs}	± 20	V	
Continuous drain current	I_d	$T_a = 25^\circ C$	-4.8	A
		$T_a = 70^\circ C$	-3.6	
Pulsed drain current	I_{dm}	-10	A	
Power dissipation	P_d	$T_a = 25^\circ C$	2.8	W
		$T_a = 70^\circ C$	1.2	
Junction and storage temperature range	T_j, T_{stg}	- 55 to 150	$^\circ C$	

■ Thermal characteristics

Parameter	Symbol	Typ.	Max.	Unit
Maximum junction-to-ambient	$R_{\theta ja}$		120	$^\circ C/W$

■ Pin configuration

SOT-223(TOP VIEW)

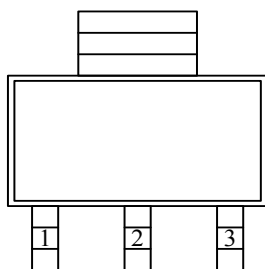

Pin No.	Pin name
1	GATE
2	DRAIN
3	SOURCE

■ Circuit

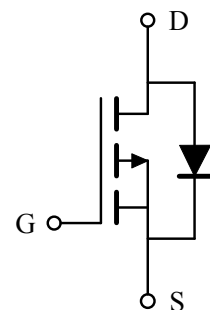

Single P-channel MOSFET

ELM5K8473A-S

■ Electrical characteristics

Ta=25°C

Parameter	Symbol	Condition	Min.	Typ.	Max.	Unit
STATIC PARAMETERS						
Drain-source breakdown voltage	BVdss	Vgs=0V, Id=-250μA	-60			V
Zero gate voltage drain current	Idss	Vds=-48V, Vgs=0V			-1	μA
		Vds=-48V, Vgs=0V, Tj=85°C			-30	
Gate-body leakage current	Igss	Vds=0V, Vgs=±12V			±100	nA
Gate threshold voltage	Vgs(th)	Vds=Vgs, Id=-250μA	-1.0		-2.0	V
On state drain current	Id(on)	Vgs=-10V, Vds=-5V	-5			A
Static drain-source on-resistance	Rds(on)	Vgs=-10V, Id=-4.8A		125	135	mΩ
		Vgs=-4.5V, Id=-3.6A		135	155	
Forward transconductance	Gfs	Vds=-15V, Id=-2.2A		5		S
Diode forward voltage	Vsd	Is=-1.5A, Vgs=0V		-0.75	-1.30	V
Max. body-diode continuous current	Is				-1.6	A
DYNAMIC PARAMETERS						
Input capacitance	Ciss	Vgs=0V, Vds=-30V, f=1MHz		410		pF
Output capacitance	Coss			45		pF
Reverse transfer capacitance	Crss			20		pF
SWITCHING PARAMETERS						
Total gate charge	Qg	Vgs=-4.5V, Vds=-30V Id=-2.2A		5.0	10.0	nC
Gate-source charge	Qgs			1.5		nC
Gate-drain charge	Qgd			2.5		nC
Turn-on delay time	td(on)	Vgs=-10V, Vds=-30V RL=16.7Ω, Id=-1.8A Rgen=1Ω		5	10	ns
Turn-on rise time	tr			15	25	ns
Turn-off delay time	td(off)			20	35	ns
Turn-off fall time	tf			10	20	ns

Single P-channel MOSFET

ELM5K8473A-S

■ Typical electrical and thermal characteristics

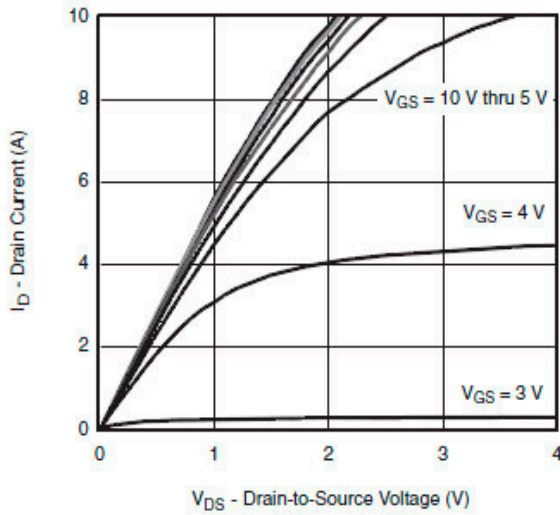

Output Characteristics

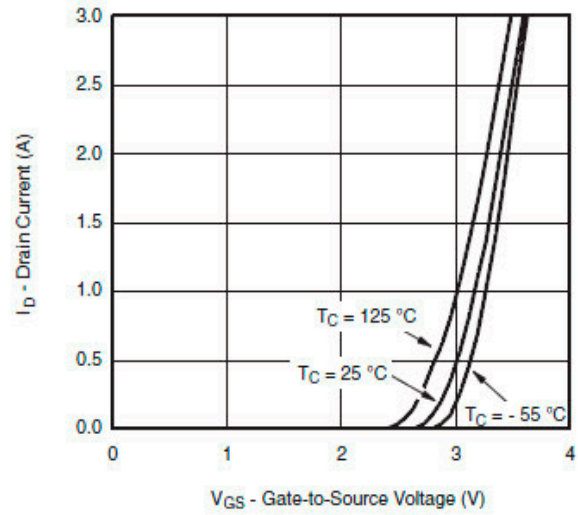

Transfer Characteristics

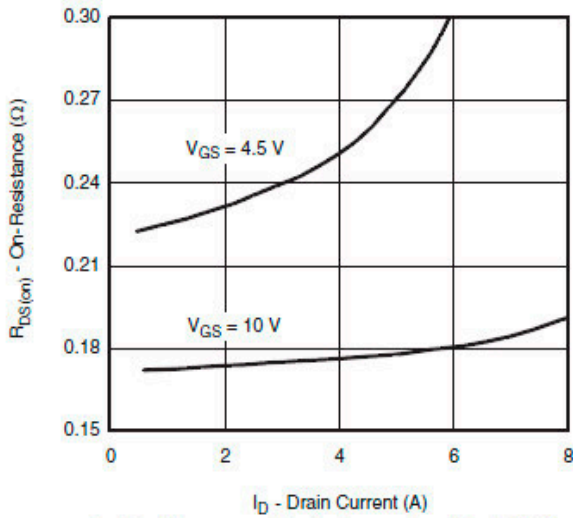

On-Resistance vs. Drain Current and Gate Voltage

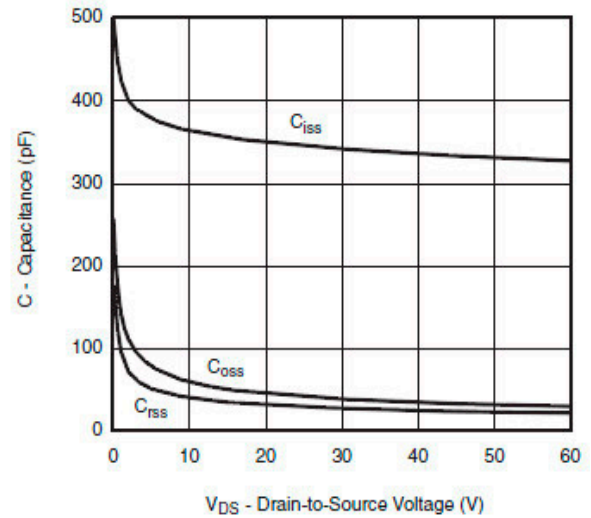

Capacitance

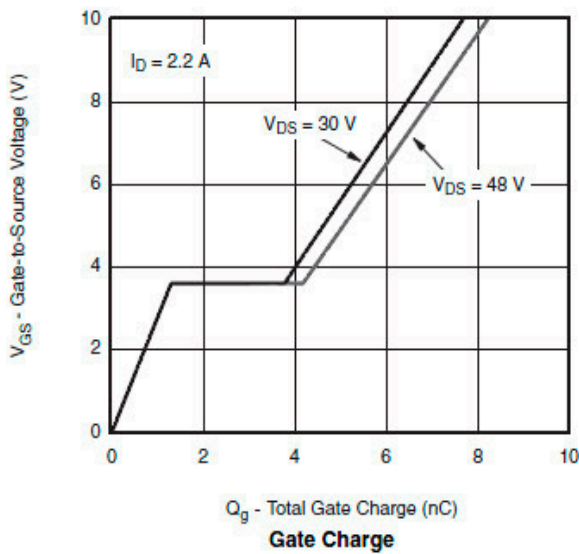

Gate Charge

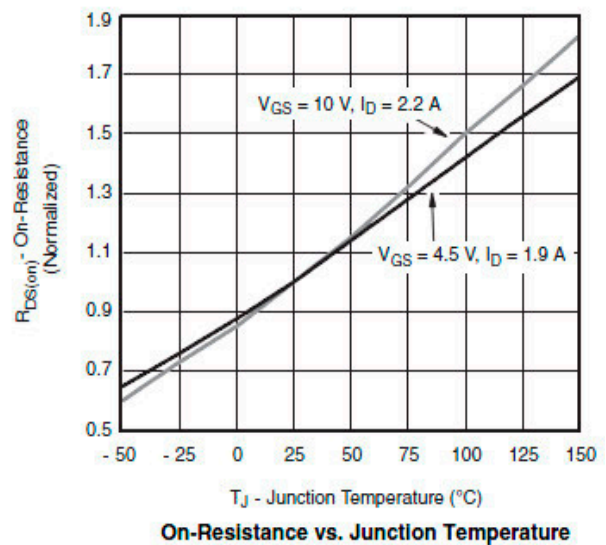

On-Resistance vs. Junction Temperature

Single P-channel MOSFET

ELM5K8473A-S

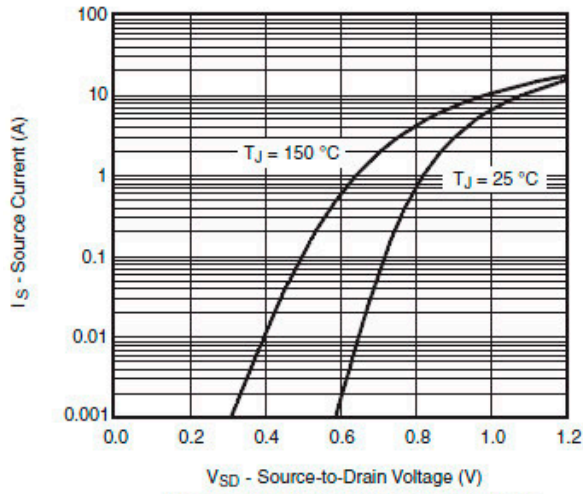

Source-Drain Diode Forward Voltage

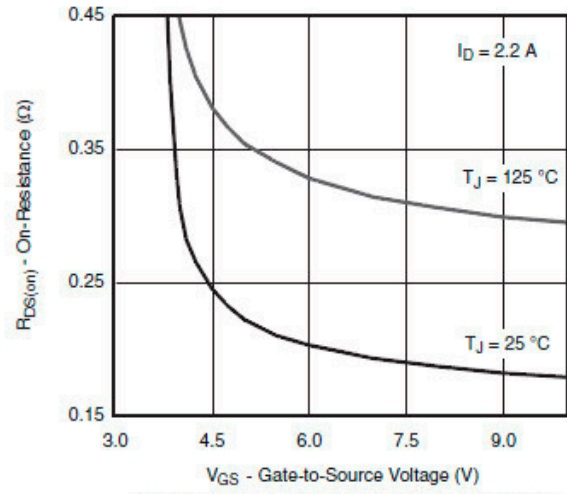

On-Resistance vs. Gate-to-Source Voltage

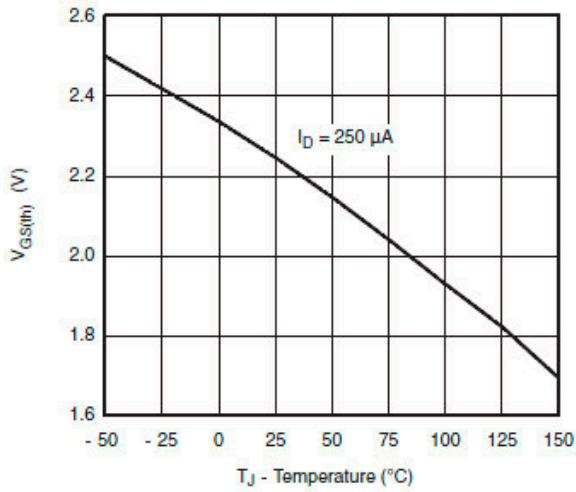

Threshold Voltage

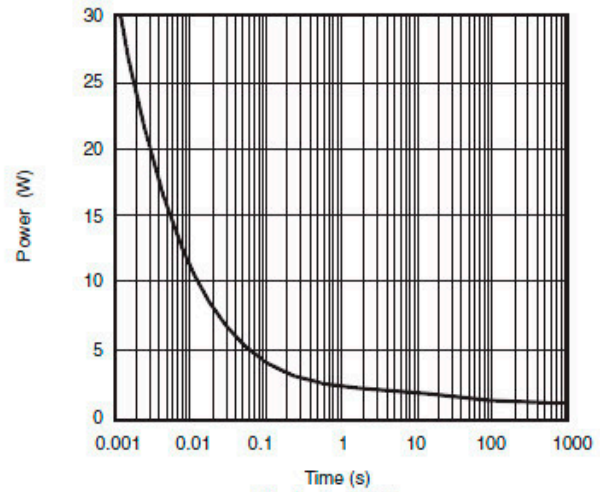

Single Pulse Power

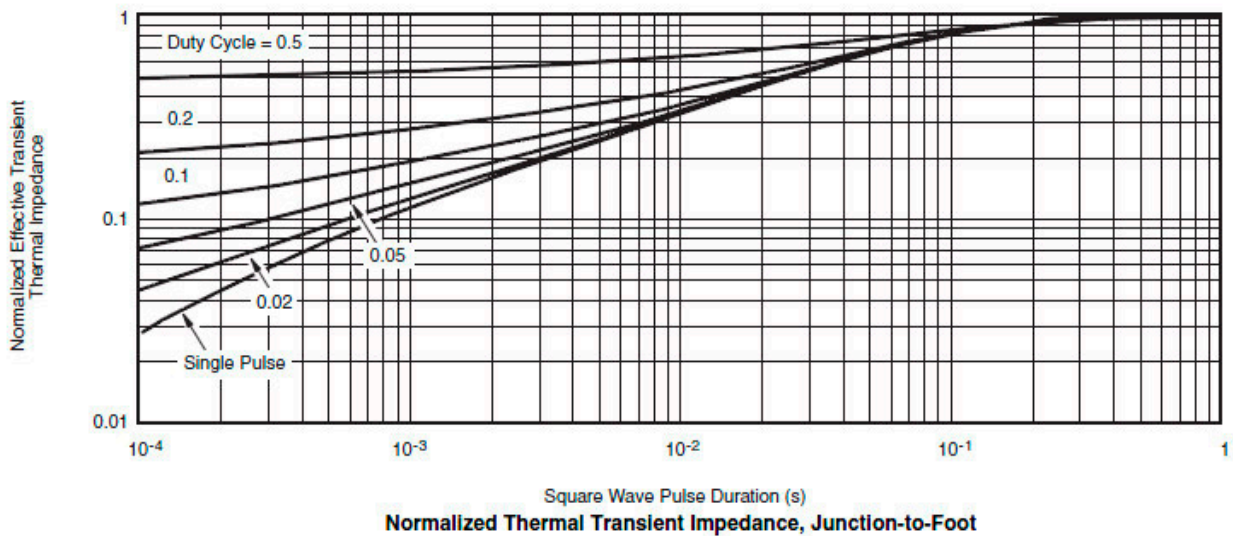

Normalized Thermal Transient Impedance, Junction-to-Foot

Single P-channel MOSFET

ELM5K8473A-S

■ Test circuit and waveform

Gate Charge Test Circuit & Waveform

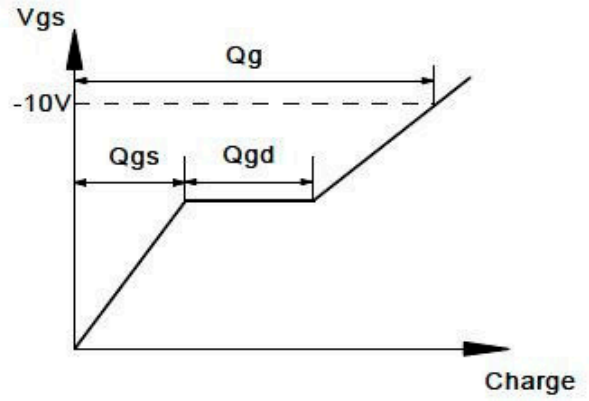
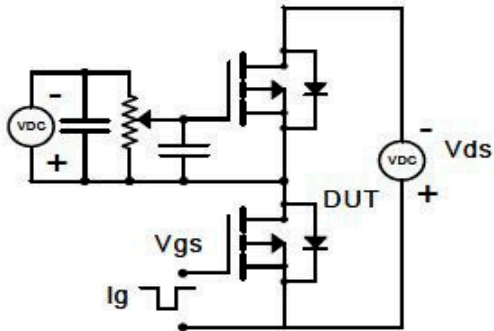

Resistive Switching Test Circuit & Waveforms

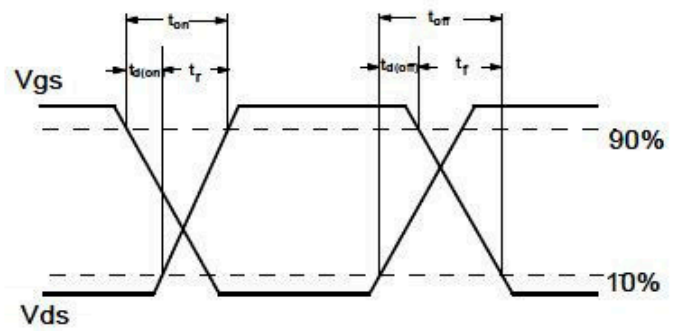
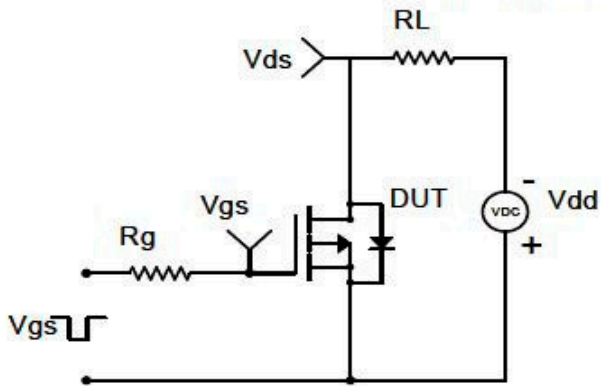

Diode Recovery Test Circuit & Waveforms

