



## SOT-323 Plastic-Encapsulate MOSFETS

### CJW1012 N-Channel Power MOSFET

#### GENERAL DESCRIPTION

This Single N-Channel MOSFET has been designed using advanced Power Trench process to optimize the  $R_{DS(ON)}$ .

#### FEATURE

- High-Side Switching
- Low On-Resistance
- Low Threshold
- Fast Switching Speed
- ESD protected up to 2kV

#### APPLICATIONS

- Drivers: Relays, Solenoids, Lamps, Hammers, Displays, Memories
- Battery Operated Systems
- Power Supply Converter Circuits
- Load/Power Switching Cell Phones, Pagers

#### MARKING: C

#### Maximum ratings ( $T_a=25^\circ\text{C}$ unless otherwise noted)

Parameter	Symbol	Value	Unit
Drain-Source voltage	$V_{DSS}$	20	V
Gate-Source Voltage	$V_{GS}$	$\pm 12$	
Drain Current-Continuous	$I_{D(DC)}$	500	mA
Drain Current -Pulsed(note1)	$I_{DM(pulse)}$	1000	
Power Dissipation (note 2 , $T_a=25^\circ\text{C}$ )	$P_D$	150	mW
Maximum Power Dissipation (note 3 , $T_c=25^\circ\text{C}$ )		275	
Thermal Resistance from Junction to Ambient	$R_{\theta JA}$	833	$^\circ\text{C/W}$
Thermal Resistance from Junction to Case	$R_{\theta JC}$	455	
Storage Temperature	$T_j$	150	$^\circ\text{C}$
Junction Temperature	$T_{stg}$	-55 ~+150	

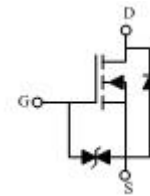
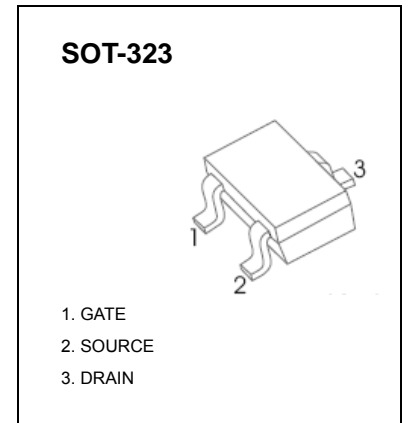

**Electrical characteristics (T<sub>a</sub>=25°C unless otherwise noted)**

Parameter	Symbol	Test Condition	Min	Typ	Max	Unit
<b>On/Off States</b>						
Drain-Source Breakdown Voltage	V <sub>(BR)DSS</sub>	V <sub>GS</sub> = 0V, I <sub>D</sub> =250μA	20			V
Gate-Threshold Voltage	V <sub>GS(th)</sub>	V <sub>DS</sub> =V <sub>GS</sub> , I <sub>D</sub> =250μA	0.45		1.2	
Gate-Body Leakage Current	I <sub>GSS</sub>	V <sub>DS</sub> =0V, V <sub>GS</sub> =±4.5V			±1	μA
Zero Gate Voltage Drain Current	I <sub>DSS</sub>	V <sub>DS</sub> =16V, V <sub>GS</sub> =0V			100	nA
Drain-Source On-State Resistance	R <sub>DSON</sub>	V <sub>GS</sub> =4.5V, I <sub>D</sub> =600mA			700	mΩ
		V <sub>GS</sub> =2.5V, I <sub>D</sub> =500mA			850	
Forward Transconductance	g <sub>FS</sub>	V <sub>DS</sub> =10V, I <sub>D</sub> =400mA		1		S
<b>Dynamic Characteristics</b>						
Input Capacitance (note 4)	C <sub>iss</sub>	V <sub>DS</sub> =16V, V <sub>GS</sub> =0V, f =1MHz		100		pF
Output Capacitance (note 4)	C <sub>oss</sub>			16		
Reverse Transfer Capacitance (note 4)	C <sub>rss</sub>			12		
Total Gate Charge	Q <sub>g</sub>	V <sub>DS</sub> =10V, V <sub>GS</sub> =4.5V, I <sub>D</sub> =250mA		750		nC
Gate-Source Charge	Q <sub>gs</sub>			75		
Gate-Drain Charge	Q <sub>gd</sub>			225		
<b>Switching Times (note 4)</b>						
Turn-On Delay Time	t <sub>d(on)</sub>	V <sub>DD</sub> =10V, R <sub>L</sub> =47Ω, I <sub>D</sub> =200mA, V <sub>GS</sub> =4.5V, R <sub>G</sub> =10Ω		5		nS
Rise Time	t <sub>r</sub>			5		
Turn-Off Delay Time	t <sub>d(off)</sub>			25		
Fall Time	t <sub>f</sub>			11		
<b>Drain-Source Diode Characteristics</b>						
Drain-Source Diode Forward Voltage (note 5)	V <sub>SD</sub>	I <sub>S</sub> =0.15A, V <sub>GS</sub> = 0V			1.2	V

**Notes:**

1. Repetitive Rating: Pulse width limited by maximum junction temperature.
2. This test is performed with no heat sink at T<sub>a</sub>=25°C.
3. This test is performed with infinite heat sink at T<sub>c</sub>=25°C.
4. These parameters have no way to verify.
5. Pulse Test : Pulse Width≤300μs, Duty Cycle≤0.5%.

# Typical Characteristics

# CJW1012

