



TO-252-2L Plastic-Encapsulate MOSFETS

CJU04N60 600V N-Channel Power MOSFET

General Description

This advanced high voltage MOSFET is designed to withstand high energy in the avalanche mode and switch efficiently. This new high energy device also offers a drain-to-source diode with fast recovery time. Designed for high voltage, high speed switching applications such as power supplies, converters, power motor controls and bridge circuits.

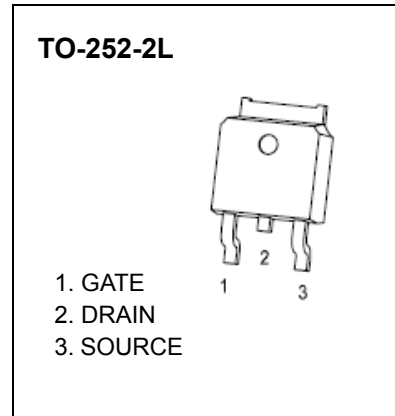

FEATURE

- High Current Rating
- Lower $R_{ds(on)}$
- Lower Capacitance
- Lower Total Gate Charge
- Tighter VSD Specifications
- Avalanche Energy Specified

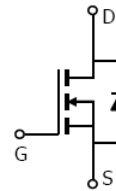

Maximum ratings ($T_a=25^\circ\text{C}$ unless otherwise noted)

Parameter	Symbol	Value	Unit
Drain-Source Voltage	V_{DS}	600	V
Gate-Source Voltage	V_{GSS}	± 30	
Continuous Drain Current	I_D	4.0	A
Continuous Drain-Source Diode Forward Current	I_S	4.0	
Single Pulsed Avalanche Energy (note1)	E_{AS}	260	mJ
Thermal Resistance from Junction to Ambient	$R_{\theta JA}$	100	$^\circ\text{C}/\text{W}$
Operating and Storage Temperature Range	T_J, T_{STG}	-55 ~ +150	$^\circ\text{C}$
Maximum lead temperature for soldering purposes , 1/8" from case for 5 seconds	T_L	260	

Electrical characteristics (T_a=25°C unless otherwise noted)

Parameter	Symbol	Test Condition	Min	Typ	Max	Unit
Off characteristics						
Drain-source breakdown voltage	V _{(BR)DSS}	V _{GS} = 0V, I _D =250μA	600			V
Drain-source diode forward voltage(note2)	V _{SD}	V _{GS} = 0V, I _S =4.0A			1.5	
Zero gate voltage drain current	I _{DSS}	V _{DS} =600V, V _{GS} =0V			25	μA
Gate-body leakage current, forward(note2)	I _{GSSF}	V _{DS} =0V, V _{GS} =30V			100	nA
Gate-body leakage current, reverse(note2)	I _{GSSR}	V _{DS} =0V, V _{GS} =-30V			-100	
On characteristics (note2)						
Gate-threshold voltage	V _{GS(th)}	V _{DS} =V _{GS} , I _D =250μA	2.0		4.0	V
Static drain-source on-resistance	R _{DSON}	V _{GS} =10V, I _D =2.0A		2.0	3.0	Ω
Forward transconductance	g _{fs}	V _{DS} =50V, I _D =2A	2.5			S
Dynamic characteristics (note 3)						
Input capacitance	C _{ISS}	V _{DS} =25V, V _{GS} =0V, f =1MHz		540	760	pF
Output capacitance	C _{OSS}			125	180	
Reverse transfer capacitance	C _{RSS}			8.0	20	
Switching characteristics						
Total gate charge	Q _g	V _{DS} =480V, V _{GS} =10V, I _D =4.0A		5.0	10	nC
Gate-source charge	Q _{gs}			2.7		
Gate-drain charge	Q _{gd}			2.0		
Turn-on delay time (note3)	t _{d(on)}	V _{DD} =300V, V _{GS} =10V, R _G =9.1Ω, I _D =4.0A		12	20	ns
Turn-on rise time (note3)	t _r			7.0	10	
Turn-off delay time (note3)	t _{d(off)}			19	40	
Turn-off fall time (note3)	t _f			10	20	

Notes :

1. L=30mH, I_L=4 A, V_{DD}=100V, V_{GS}=10V, R_G=25Ω, Starting T_J=25°C.
2. Pulse Test : Pulse width≤300μs, duty cycle ≤2%.
3. These parameters have no way to verify.

Typical Characteristics

CJU04N60

Output Characteristics

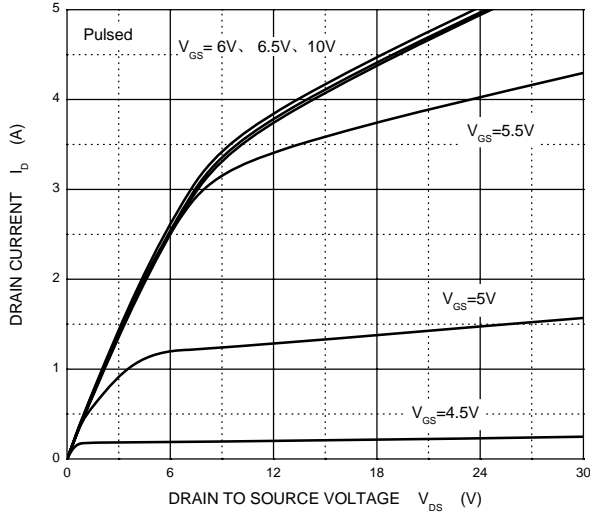

Transfer Characteristics

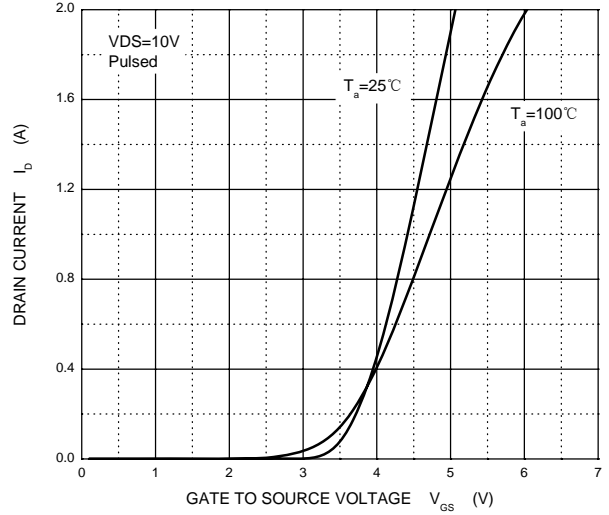

$R_{DS(ON)}$ — I_D

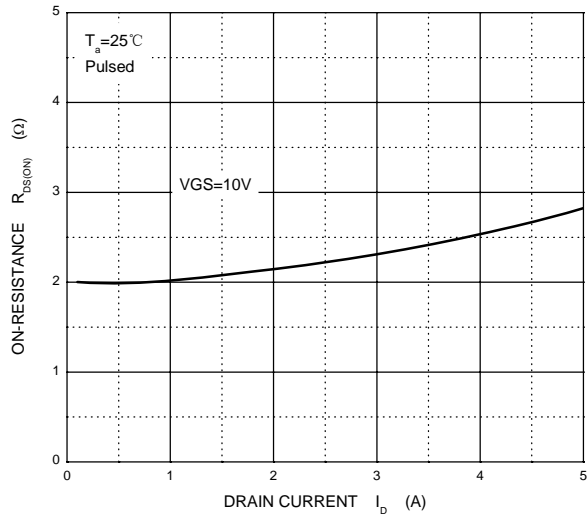

$R_{DS(ON)}$ — V_{GS}

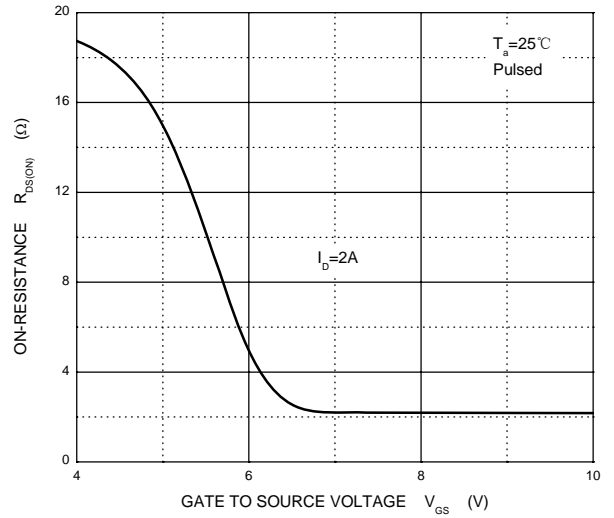

I_s — V_{SD}

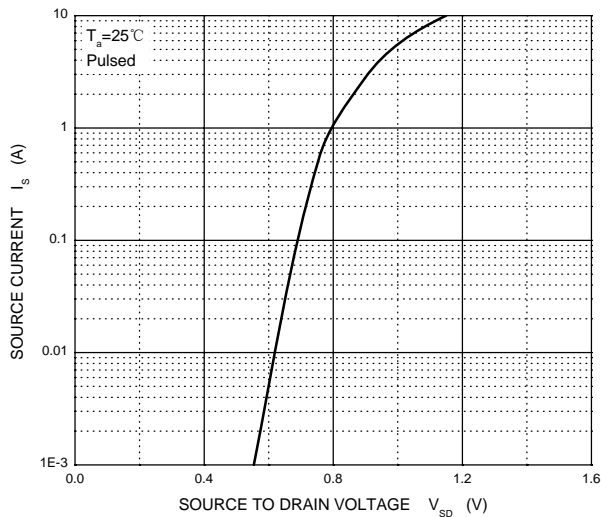

Threshold Voltage

