



TO-92 Plastic-Encapsulate Transistors

9013S TRANSISTOR (NPN)

FEATURES

- Complementary to 9012S
- Excellent h_{FE} linearity

MAXIMUM RATINGS ($T_a=25^\circ\text{C}$ unless otherwise noted)

Symbol	Parameter	Value	Units
V_{CBO}	Collector-Base Voltage	40	V
V_{CEO}	Collector-Emitter Voltage	25	V
V_{EBO}	Emitter-Base Voltage	5	V
I_C	Collector Current -Continuous	500	mA
P_C	Collector Dissipation	625	mW
T_J	Junction Temperature	150	$^\circ\text{C}$
T_{stg}	Storage Temperature	-55-150	$^\circ\text{C}$

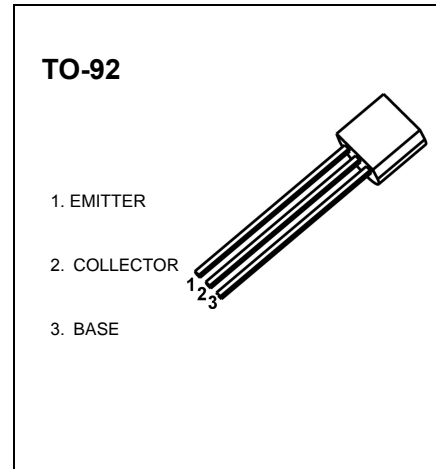

ELECTRICAL CHARACTERISTICS ($T_a=25^\circ\text{C}$ unless otherwise specified)

Parameter	Symbol	Test conditions	Min	Typ	Max	Unit
Collector-base breakdown voltage	$V_{(BR)CBO}$	$I_C = 100\mu\text{A}$, $I_E = 0$	40			V
Collector-emitter breakdown voltage	$V_{(BR)CEO}$	$I_C = 1\text{mA}$, $I_B = 0$	25			V
Emitter-base breakdown voltage	$V_{(BR)EBO}$	$I_E = 100\mu\text{A}$, $I_C = 0$	5			V
Collector cut-off current	I_{CBO}	$V_{CB} = 40\text{V}$, $I_E = 0$			0.1	μA
Collector cut-off current	I_{CEO}	$V_{CE} = 20\text{V}$, $I_E = 0$			0.1	μA
Emitter cut-off current	I_{EBO}	$V_{EB} = 5\text{V}$, $I_C = 0$			0.1	μA
DC current gain	$h_{FE(1)}$	$V_{CE} = 1\text{V}$, $I_C = 50\text{mA}$	64		400	
	$h_{FE(2)}$	$V_{CE} = 1\text{V}$, $I_C = 500\text{mA}$	40			
Collector-emitter saturation voltage	$V_{CE(sat)}$	$I_C = 500\text{mA}$, $I_B = 50\text{mA}$			0.6	V
Base-emitter voltage	$V_{BE(sat)}$	$I_C = 500\text{mA}$, $I_B = 50\text{mA}$			1.2	V
Transition frequency	f_T	$V_{CE} = 6\text{V}$, $I_C = 20\text{mA}$, $f = 30\text{MHz}$	150			MHz

CLASSIFICATION OF $h_{FE(1)}$

Rank	D	E	F	G	H	I	J
Range	64-91	78-112	96-135	112-166	144-202	190-300	300-400

Typical Characteristics

9013S

Static Characteristic

