



TO-126 Plastic-Encapsulate Transistors

3CA772 TRANSISTOR (PNP)

FEATURES

- High Current
- Low Voltage

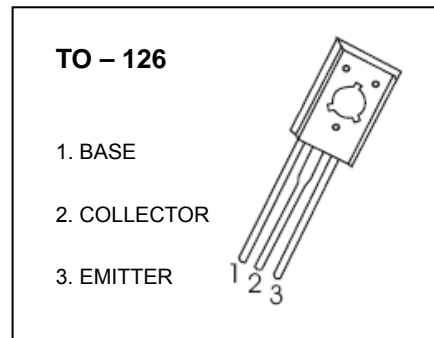

MAXIMUM RATINGS ($T_a=25^{\circ}\text{C}$ unless otherwise noted)

Symbol	Parameter	Value	Unit
V_{CB0}	Collector-Base Voltage	-40	V
V_{CE0}	Collector-Emitter Voltage	-30	V
V_{EB0}	Emitter-Base Voltage	-6	V
I_C	Collector Current	-3	A
P_C	Collector Power Dissipation	1.25	W
$R_{\theta JA}$	Thermal Resistance From Junction To Ambient	100	$^{\circ}\text{C/W}$
T_j	Junction Temperature	150	$^{\circ}\text{C}$
T_{stg}	Storage Temperature	-55~+150	$^{\circ}\text{C}$

ELECTRICAL CHARACTERISTICS ($T_a=25^{\circ}\text{C}$ unless otherwise specified)

Parameter	Symbol	Test conditions	Min	Typ	Max	Unit
Collector-base breakdown voltage	$V_{(BR)CB0}$	$I_C=-100\mu\text{A}, I_E=0$	-40			V
Collector-emitter breakdown voltage	$V_{(BR)CE0}$	$I_C=-10\text{mA}, I_B=0$	-30			V
Emitter-base breakdown voltage	$V_{(BR)EBO}$	$I_E=-100\mu\text{A}, I_C=0$	-6			V
Collector cut-off current	I_{CB0}	$V_{CB}=-40\text{V}, I_E=0$			-1	μA
Collector cut-off current	I_{CE0}	$V_{CE}=-30\text{V}, I_B=0$			-10	μA
Emitter cut-off current	I_{EBO}	$V_{EB}=-6\text{V}, I_C=0$			-1	μA
DC current gain	h_{FE}	$V_{CE}=-2\text{V}, I_C=-1\text{A}$	60		400	
Collector-emitter saturation voltage	$V_{CE(sat)}$	$I_C=-2\text{A}, I_B=-0.2\text{A}$			-0.5	V
Base-emitter saturation voltage	$V_{BE(sat)}$	$I_C=-2\text{A}, I_B=-0.2\text{A}$			-1.5	V
Transition frequency	f_T	$V_{CE}=-5\text{V}, I_C=-0.1\text{A}, f=10\text{MHz}$	50			MHz

CLASSIFICATION OF h_{FE}

RANK	R	O	Y	GR
RANGE	60-120	100-200	160-320	200-400