

## LOW FORWARD DROP VOLTAGE SCHOTTKY RECTIFIER

### Features

- Low forward voltage drop
- Low power loss and High efficiency
- Low leakage current
- High surge capability
- “Green” device and RoHS compliant device



### Applications

- High efficiency SMPS
- Output rectification
- High frequency switching
- Freewheeling
- DC-DC converter systems

### Description

The SDB1060D is ideally suited for a full wave output rectifier in low switching power supplies, inverters and as free wheeling diodes.

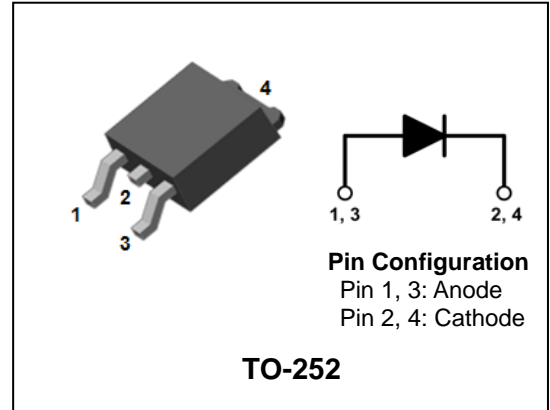

### Product Characteristics

$I_{F(AV)}$	10A
$V_{RRM}$	60V
$V_{FM}$ at 125°C	0.55V
$I_{FSM}$	120A

### Ordering Information

Device	Marking Code	Package	Packaging
SDB1060D	SDB1060D	TO-252	Tape & Reel

### Marking Information

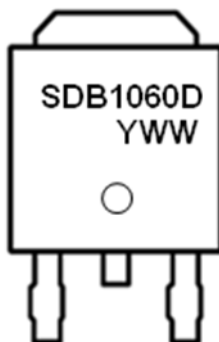

- SDB1060D = Specific Device Code**  
**YWW = Year & Week Code Marking**  
 -. Y = Year Code  
 -. WW = Week Code

## Absolute Maximum Ratings (Limiting Values)

Characteristic	Symbol	Value	Unit
Maximum repetitive reverse voltage Maximum working peak reverse voltage Maximum DC blocking voltage	$V_{RRM}$ $V_{RWM}$ $V_R$	60	V
Maximum average forward rectified current	$I_{F(AV)}$	10	A
Peak forward surge current 8.3ms single half sine-wave superimposed on rated load per diode	$I_{FSM}$	120	A
Storage temperature range	$T_{stg}$	-45°C to +150°C	°C
Maximum operating junction temperature	$T_J$	150	°C

## Thermal Characteristics

Characteristic	Symbol	Value	Unit
Maximum thermal resistance junction to case	$R_{th(j-c)}$	4.0	°C/W

## Electrical Characteristics

Characteristic	Symbol	Test Condition	Min.	Typ.	Max.	Unit	
Peak forward voltage drop	$V_{FM}^{(1)}$	$I_{FM} = 10A$	$T_j = 25^\circ C$	-	0.55	0.65	V
			$T_j = 125^\circ C$	-	0.50	0.55	V
Reverse leakage current	$I_{RM}^{(1)}$	$V_R = V_{RRM}$	$T_j = 25^\circ C$	-	-	1.5	mA
			$T_j = 125^\circ C$	-	-	200	mA
Junction capacitance	$C_j$	$V_R = 4V_{DC}, f=1MHz$	-	400	-	pF	

**Note :** (1) Pulse test :  $t_p \leq 380 \mu s$ , Duty cycle  $\leq 2\%$

To evaluate the conduction losses use the following equation:  $P_F = 0.35 I_{F(AV)} + 0.019 I_{F(RMS)}^2$

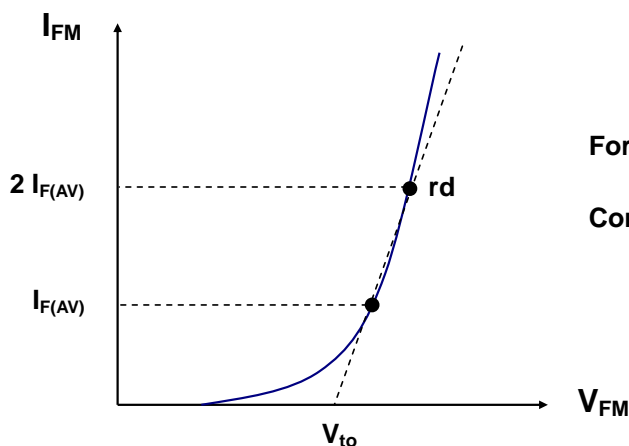

$$\text{Forward Voltage : } V_{FM} = V_{to} + rd I_{FM}$$

$$\text{Conduction Loss : } P_F = V_{to} I_{F(AV)} + rd I_{F(RMS)}^2$$

## Rating and Characteristic Curves

Fig. 1) Typical Forward Characteristics

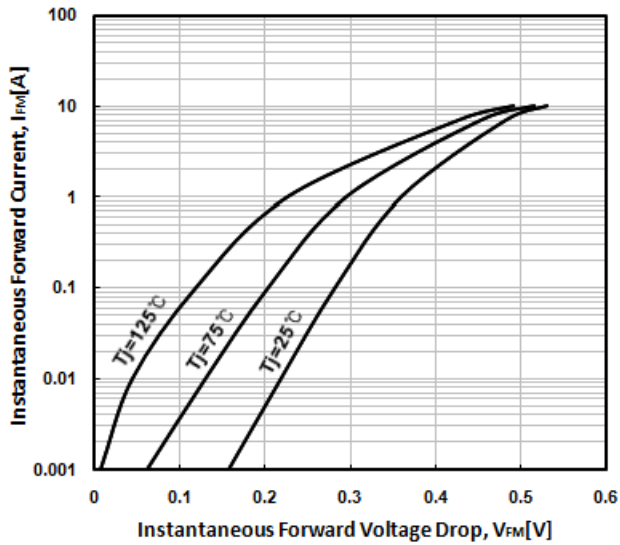

Fig. 2) Typical Reverse Characteristics

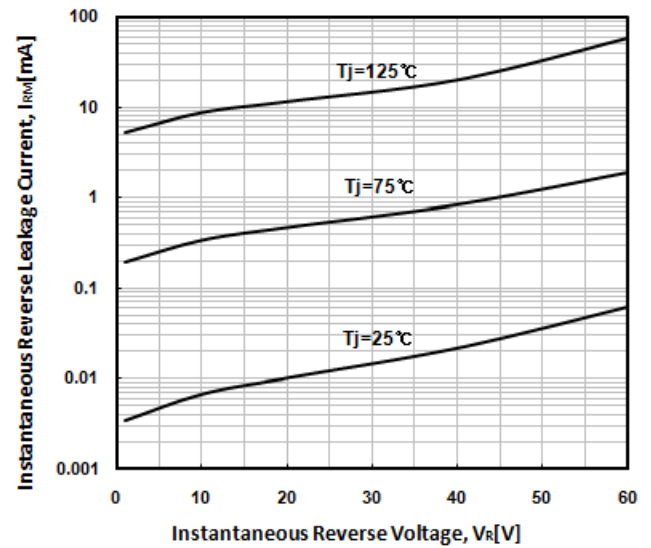

Fig. 3) Maximum Forward Derivative Curve

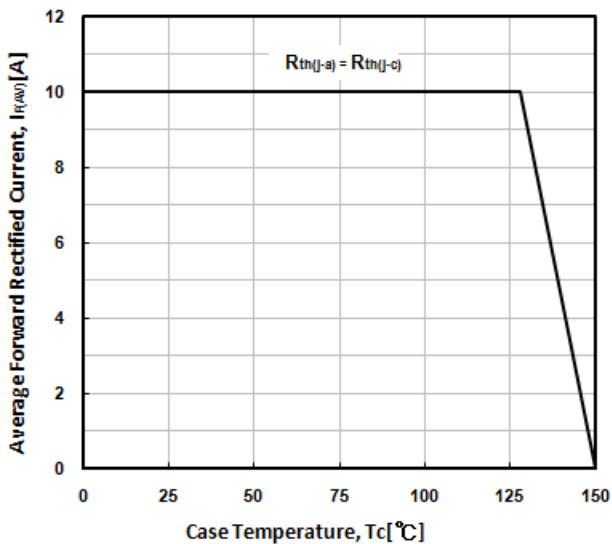

Fig. 4) Forward Power Dissipation

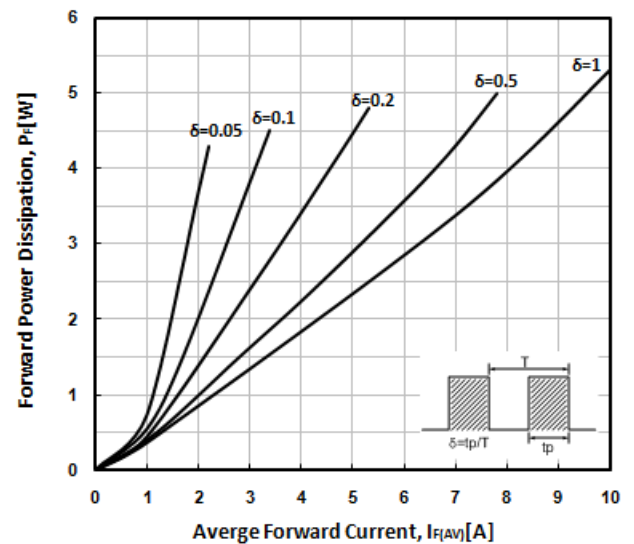

Fig. 5) Maximum Non-Repetitive Peak Forward Surge Current

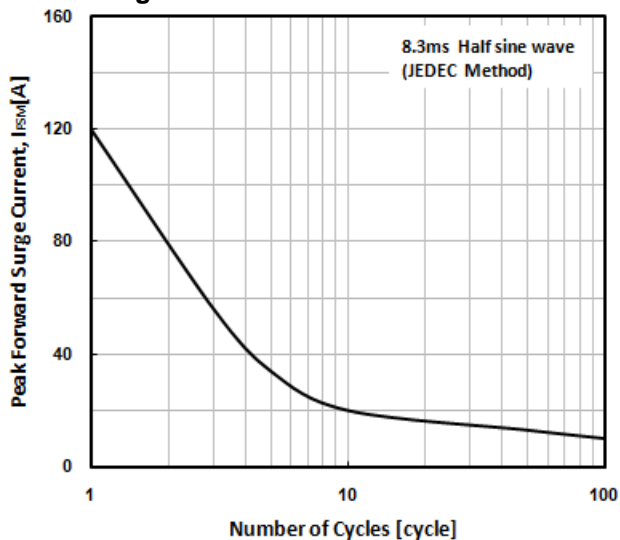
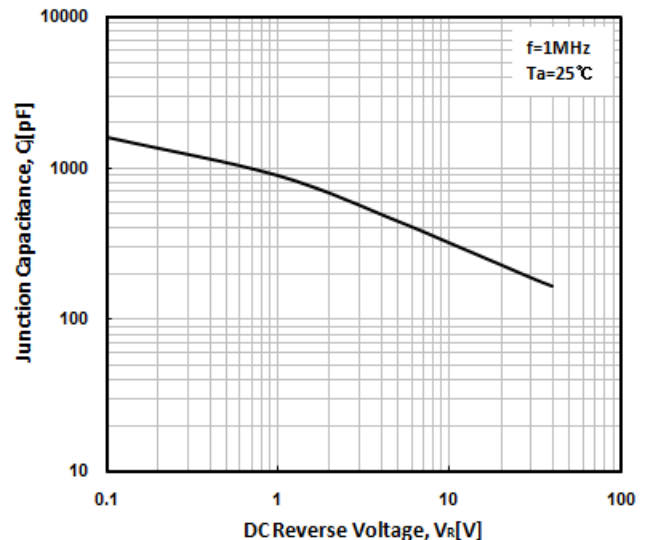
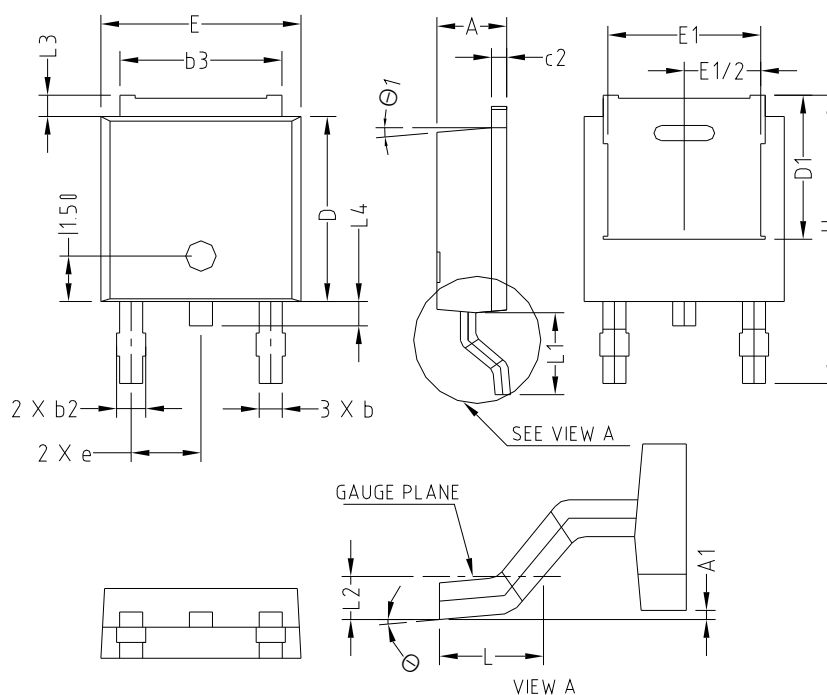

Fig. 6) Typical Junction Capacitance



## Package Outline Dimension



SYMBOL	MILLIMETERS			NOTE
	MINIMUM	NOMINAL	MAXIMUM	
A	2.20	2.30	2.40	
A1	0.00		0.127	
b	0.66	0.76	0.86	
b2	-	-	0.96	
b3	5.04	5.34	5.64	
c2	0.40	0.50	0.60	
D	5.90	6.10	6.30	
D1	4.75			
E	6.40	6.60	6.80	
E1	5.04			
e	2.30 BSC			
H	9.20	9.50	9.80	
L	1.27	1.47	1.67	
L1	2.50	2.70	2.90	
L2	0.508 BSC			
L3	0.50	0.70	0.90	
L4	0.60	0.80	1.00	
⊖	0°	-	10°	
⊖1	5°			

### ※ Recommended Land Pattern (Unit: mm)

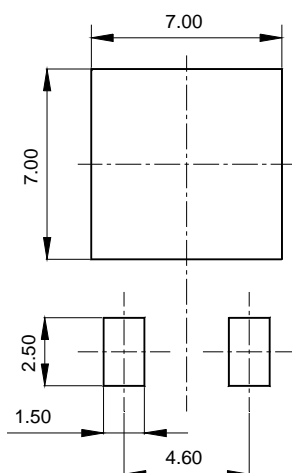

**The AUK Corp. products are intended for the use as components in general electronic equipment (Office and communication equipment, measuring equipment, home appliance, etc.).**

**Please make sure that you consult with us before you use these AUK Corp. products in equipments which require high quality and / or reliability, and in equipments which could have major impact to the welfare of human life(atomic energy control, airplane, spaceship, transportation, combustion control, all types of safety device, etc.). AUK Corp. cannot accept liability to any damage which may occur in case these AUK Corp. products were used in the mentioned equipments without prior consultation with AUK Corp..**

**Specifications mentioned in this publication are subject to change without notice.**