

60A, 30V, Avalanche Rated, P-Channel Enhancement-Mode Power MOSFETs

December 1995

Features

- 60A, 30V
- $r_{DS(ON)} = 0.027\Omega$
- Temperature Compensating PSPICE Model
- Peak Current vs Pulse Width Curve
- UIS Rating Curve
- +175°C Operating Temperature

Description

The RFG60P03, RFP60P03, RF1S60P03 and RF1S60P03SM P-Channel power MOSFETs are manufactured using the MegaFET process. This process, which uses feature sizes approaching those of LSI integrated circuits gives optimum utilization of silicon, resulting in outstanding performance. They were designed for use in applications such as switching regulators, switching converters, motor drivers and relay drivers. These transistors can be operated directly from integrated circuits.

PACKAGE AVAILABILITY

| PART NUMBER | PACKAGE | BRAND |
|-------------|----------|----------|
| RFG60P03 | TO-247 | RFG60P03 |
| RFP60P03 | TO-220AB | RFP60P03 |
| RF1S60P03 | TO-262AA | F1S60P03 |
| RF1S60P03SM | TO-263AB | F1S60P03 |

NOTE: When ordering use the entire part number.

Formerly developmental type TA49045.

Symbol

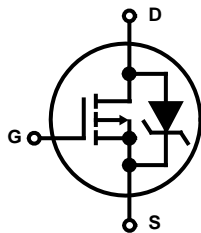

Packages

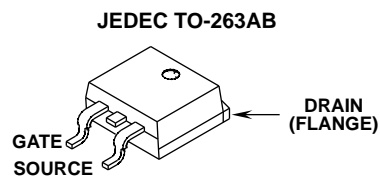
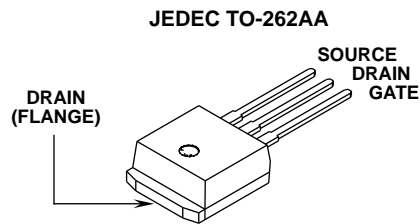
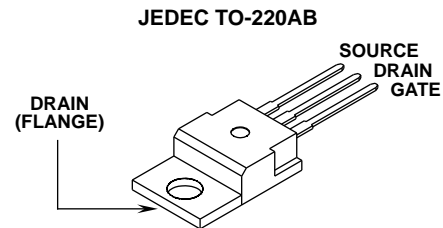
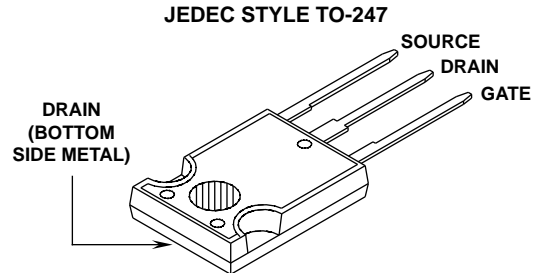

Absolute Maximum Ratings $T_C = +25^\circ\text{C}$

| | | RFG60P03, RFP60P03, RF1S60P03, RFS60P03SM | UNITS |
|-----------------------------------|----------------|--|-------|
| Drain Source Voltage | V_{DSS} | -30 | V |
| Drain Gate Voltage | V_{DGR} | -30 | V |
| Gate Source Voltage | V_{GS} | ± 20 | V |
| Drain Current | | | |
| RMS Continuous | I_D | 60 | A |
| Pulsed Drain Current | I_{DM} | Refer to Peak Current Curve | |
| Single Pulse Avalanche Rating | E_{AS} | Refer to UIS Curve | |
| Power Dissipation | | | |
| $T_C = +25^\circ\text{C}$ | P_D | 176 | W |
| Derate above +25°C | P_T | 1.17 | W/°C |
| Operating and Storage Temperature | T_J, T_{STG} | -55 to +175 | °C |

CAUTION: These devices are sensitive to electrostatic discharge. Users should follow proper ESD handling procedures.

Specifications RFG60P03, RFP60P03, RF1S60P03, RF1S60P03SM

Electrical Specifications $T_C = +25^\circ\text{C}$, Unless Otherwise Specified.

| PARAMETERS | SYMBOL | TEST CONDITIONS | MIN | TYP | MAX | UNITS | |
|---|-----------------|--|-------------------------------|---|--------------------|--------------------|---------------|
| Drain-Source Breakdown Voltage | BV_{DSS} | $I_D = 250\mu\text{A}$, $V_{GS} = 0\text{V}$ | -30 | - | - | V | |
| Gate Threshold Voltage | $V_{GS(TH)}$ | $V_{GS} = V_{DS}$, $I_D = 250\mu\text{A}$ | -2 | - | -4 | V | |
| Zero Gate Voltage Drain Current | I_{DSS} | $V_{DS} = -30\text{V}$, $V_{GS} = 0\text{V}$ | $T_C = +25^\circ\text{C}$ | - | - | -1 | μA |
| | | | $T_C = +150^\circ\text{C}$ | - | - | -50 | μA |
| Gate-Source Leakage Current | I_{GSS} | $V_{GS} = \pm 20\text{V}$ | - | - | 100 | nA | |
| On Resistance | $r_{DS(ON)}$ | $I_D = 60\text{A}$, $V_{GS} = -10\text{V}$ | - | - | 0.027 | Ω | |
| Turn-On Time | t_{ON} | $V_{DD} = -15\text{V}$, $I_D = 60\text{A}$ $R_L = 0.25\Omega$, $V_{GS} = -10\text{V}$ $R_{GS} = 2.5\Omega$ | - | - | 140 | ns | |
| Turn-On Delay Time | $t_{D(ON)}$ | | - | 20 | - | ns | |
| Rise Time | t_R | | - | 75 | - | ns | |
| Turn-Off Delay Time | $t_{D(OFF)}$ | | - | 35 | - | ns | |
| Fall Time | t_F | | - | 40 | - | ns | |
| Turn-Off Time | t_{OFF} | | - | - | 115 | ns | |
| Total Gate Charge | $Q_{G(TOT)}$ | | $V_{GS} = 0$ to -20V | $V_{DD} = -24\text{V}$, $I_D = 60\text{A}$, $R_L = 0.4\Omega$ | - | 190 | 230 |
| Gate Charge at 10V | $Q_{G(-10)}$ | $V_{GS} = 0$ to -10V | - | | 100 | 120 | nC |
| Threshold Gate Charge | $Q_{G(TH)}$ | $V_{GS} = 0$ to -2V | - | | 7.5 | 9 | nC |
| Input Capacitance | C_{ISS} | $V_{DS} = -25\text{V}$, $V_{GS} = 0\text{V}$ $f = 1\text{MHz}$ | - | 3000 | - | pF | |
| Output Capacitance | C_{OSS} | | - | 1500 | - | pF | |
| Reverse Transfer Capacitance | C_{RSS} | | - | 525 | - | pF | |
| Thermal Resistance, Junction to Case | $R_{\theta JC}$ | | - | - | 0.85 | $^\circ\text{C/W}$ | |
| Thermal Resistance, Junction to Ambient | $R_{\theta JA}$ | - | - | 80 | $^\circ\text{C/W}$ | | |

Source-Drain Diode Ratings and Specifications

| PARAMETERS | SYMBOL | TEST CONDITIONS | MIN | TYP | MAX | UNITS |
|-----------------------|----------|--|-----|-----|-------|-------|
| Forward Voltage | V_{SD} | $I_{SD} = -60\text{A}$ | - | - | -1.75 | V |
| Reverse Recovery Time | t_{RR} | $I_{SD} = -60\text{A}$, $dI_{SD}/dt = -100\text{A}/\mu\text{s}$ | - | - | 200 | ns |

Typical Performance Curves

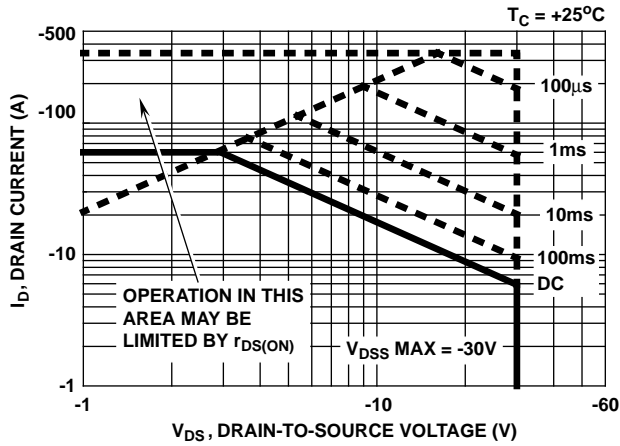

FIGURE 1. SAFE OPERATING AREA CURVE

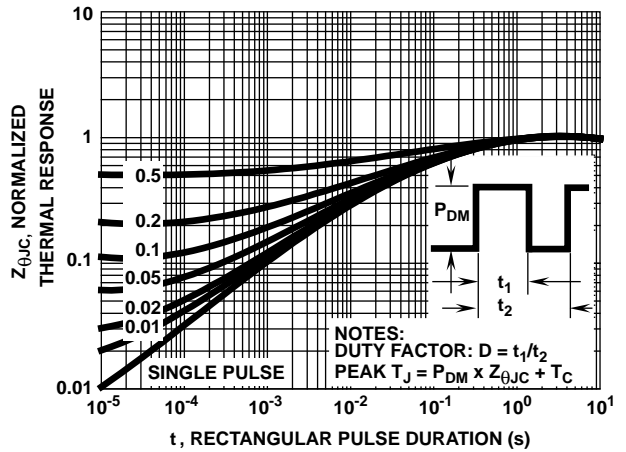

FIGURE 2. NORMALIZED MAXIMUM TRANSIENT THERMAL IMPEDANCE

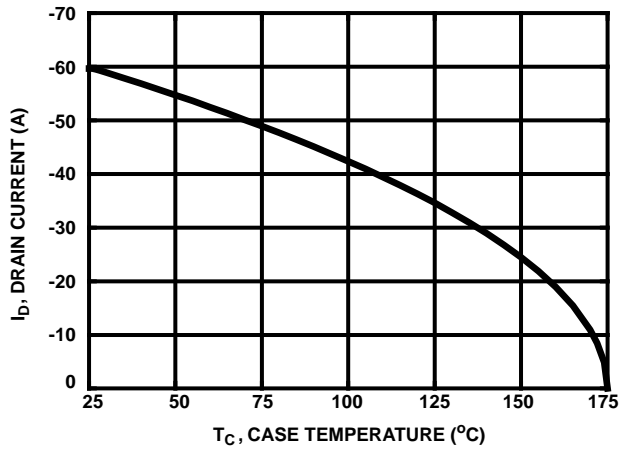

FIGURE 3. MAXIMUM CONTINUOUS DRAIN CURRENT vs TEMPERATURE

10⁻⁶

FIGURE 4. PEAK CURRENT CAPABILITY

FIGURE 5. TYPICAL SATURATION CHARACTERISTICS

FIGURE 6. TYPICAL TRANSFER CHARACTERISTICS

Typical Performance Curves (Continued)

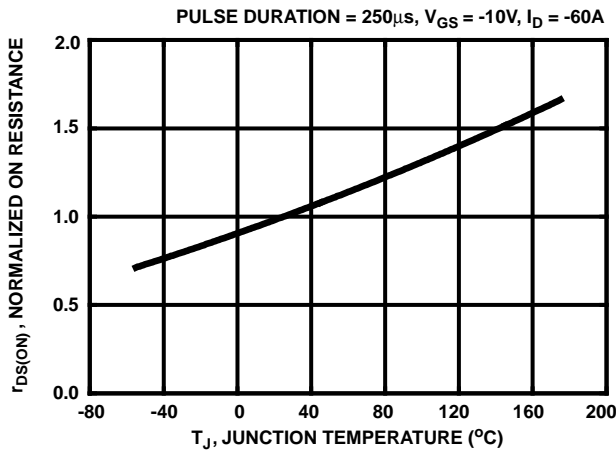

FIGURE 7. NORMALIZED $r_{DS(ON)}$ vs JUNCTION TEMPERATURE

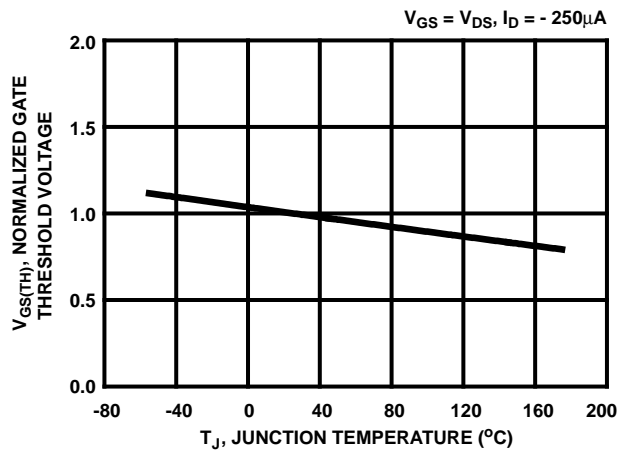

FIGURE 8. NORMALIZED GATE THRESHOLD VOLTAGE vs TEMPERATURE

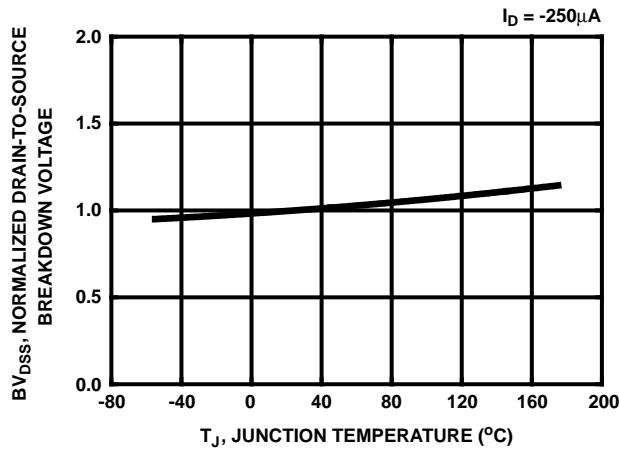

FIGURE 9. NORMALIZED DRAIN SOURCE BREAKDOWN VOLTAGE vs TEMPERATURE

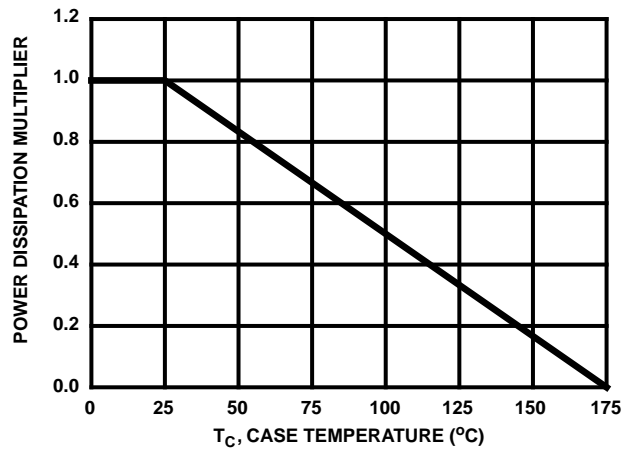

FIGURE 10. NORMALIZED SWITCHING WAVEFORMS

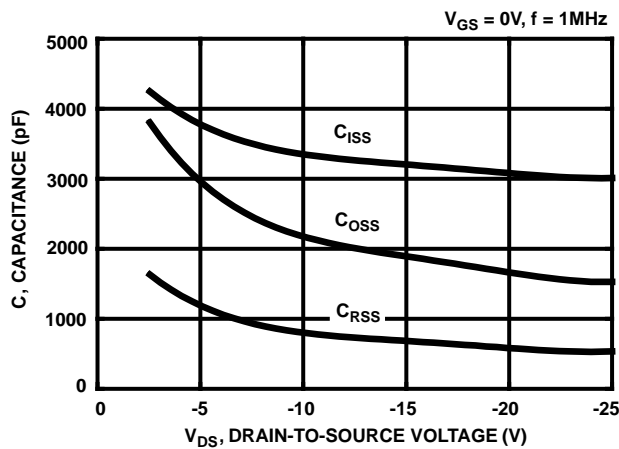

FIGURE 11. TYPICAL CAPACITANCE vs VOLTAGE

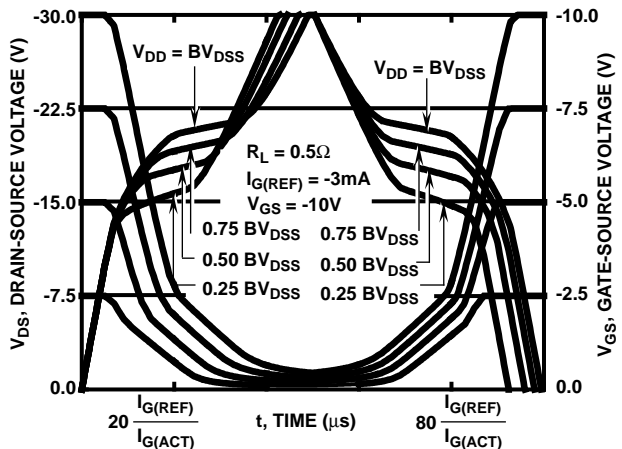

FIGURE 12. NORMALIZED SWITCHING WAVEFORMS FOR CONSTANT GATE CURRENT. REFER TO APPLICATION NOTE AN7254 AND AN7260

Typical Performance Curves (Continued)

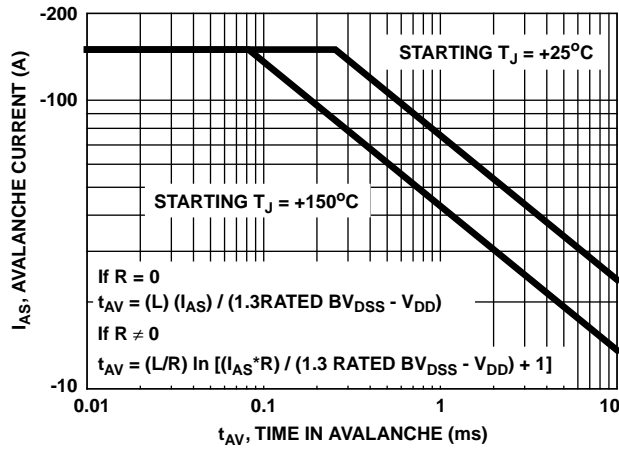

FIGURE 13. UNCLAMPED INDUCTIVE SWITCHING

Test Circuits and Waveforms

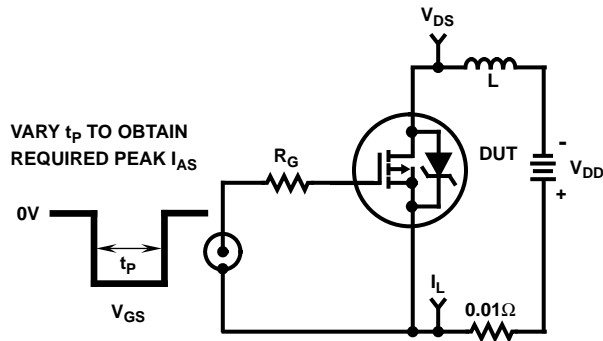

FIGURE 14. UNCLAMPED ENERGY TEST CIRCUIT

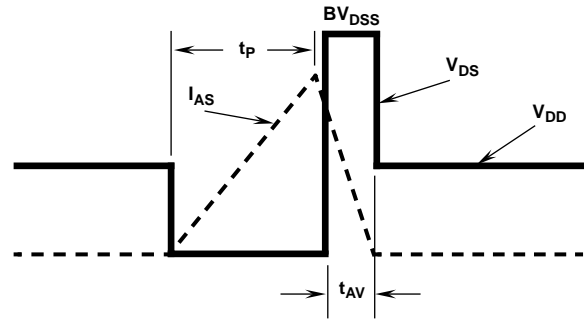

FIGURE 15. UNCLAMPED ENERGY WAVEFORMS

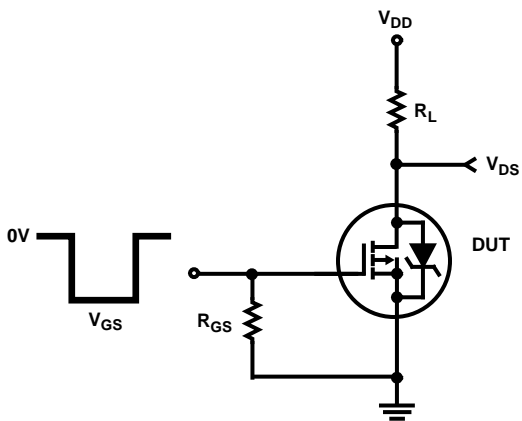

FIGURE 16. RESISTIVE SWITCHING TEST CIRCUIT

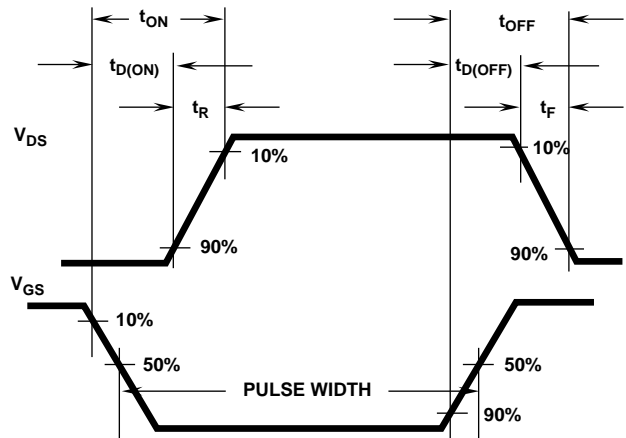

FIGURE 17. RESISTIVE SWITCHING WAVEFORMS

RFG60P03, RFP60P03, RF1S60P03, RF1S60P03SM

Temperature Compensated PSPICE Model for the RFG60P03, RFP60P03, RF1S60P03, RF1S60P03SM

.SUBCKT RFP60P03 2 1 3

REV 6/21/94

CA 12 8 5.01e-9

CB 15 14 3.9e-9

CIN 6 8 3.09e-9

DBODY 5 7 DBDMOD

DBREAK 7 11 DBKMOD

DPLCAP 10 6 DPLCAPMOD

EBREAK 5 11 17 18 -36.59

EDS 14 8 5 8 1

EGS 13 8 6 8 1

ESG 5 10 8 6 1

EVTO 20 6 8 18 1

IT 8 17 1

LDRAIN 2 5 1e-9

LGATE 1 9 4.92e-9

LSOURCE 3 7 2.36e-9

MOS1 16 6 8 8 MOSMOD M=0.99

MOS2 16 21 8 8 MOSMOD M=0.01

RBREAK 17 18 RBKMOD 1

RDRAIN 5 16 RDSMOD 1e-4

RGATE 9 20 3.25

RIN 6 8 1e9

RSOURCE 8 7 RDSMOD 11.28e-3

RVTO 18 19 RVTOMOD 1

S1A 6 12 13 8 S1AMOD

S1B 13 12 13 8 S1BMOD

S2A 6 15 14 13 S2AMOD

S2B 13 15 14 13 S2BMOD

VBAT 8 19 DC 1

VTO 21 6 -0.92

.MODEL DBDMOD D (IS=4.21e-13 RS=1e-2 TRS1=-2.69e-4 TRS2=-1.33e-6 CJO=5.05e-9 TT=5.33e-8)

.MODEL DBKMOD D (RS=3.80e-2 TRS1=-4.76e-4 TRS2=-4.17e-12)

.MODEL DPLCAPMOD D (CJO=4.05e-9 IS=1e-30 N=10)

.MODEL MOSMOD PMOS (VTO=-3.98 KP=16.27 IS=1e-30 N=10 TOX=1 L=1u W=1u)

.MODEL RBKMOD RES (TC1=8.05e-4 TC2=1.48e-6)

.MODEL RDSMOD RES (TC1=2.80e-3 TC2=2.62e-6)

.MODEL RVTOMOD RES (TC1=-3.34e-3 TC2=1.46e-6)

.MODEL S1AMOD VSWITCH (RON=1e-5 ROFF=0.1 VON=7.5 VOFF=4.5)

.MODEL S1BMOD VSWITCH (RON=1e-5 ROFF=0.1 VON=4.5 VOFF=7.5)

.MODEL S2AMOD VSWITCH (RON=1e-5 ROFF=0.1 VON=1.43 VOFF=-3.57)

.MODEL S2BMOD VSWITCH (RON=1e-5 ROFF=0.1 VON=-3.57 VOFF=1.43)

.ENDS

NOTE: For further discussion of the PSPICE model consult **A New PSPICE Sub-circuit for the Power MOSFET Featuring Global Temperature Options**; authors, William J. Hepp and C. Frank Wheatley.

