

用途:用于高效 DC/DC 转换和功率开关。

Purpose: These devices are well suited for high efficiency switching DC/DC converters and switch mode power supplies.

特点: 低栅电荷, 低反馈电容, 开关速度快。

Features: Low gate charge, low crss, fast switching.

极限参数/Absolute maximum ratings(Ta=25°C)

参数符号 Symbol	数值 Rating	单位 Unit
V _{DSS}	200	V
I _D (T _C =25°C)	18	A
I _D (T _C =100°C)	11.4	A
I _{DM}	72	A
V _{GSS}	±30	V
E _{AS}	250	mJ
E _{AR}	13.9	mJ
I _{AR}	18	A
P _D (T _C =25°C)	43	W
T _J , T _{STG}	-55 to 150	°C

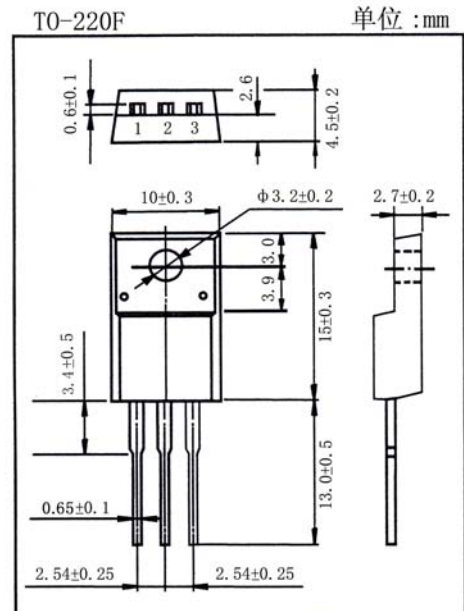

引脚: 1.G 2.D 3.S

电性能参数/Electrical Characteristics(Ta=25°C)

参数符号 Symbol	测试条件 Test Conditions	最小值 Min	典型值 Typ	最大值 Max	单位 Unit
BV _{DSS}	V _{GS} =0V I _D =250 μA	200			V
I _{DSS}	V _{DS} =200V V _{GS} =0V			10	μA
	V _{DS} =160V T _C =125°C			100	μA
I _{GSS}	V _{GS} =±30V V _{DS} =0V			±0.1	μA
V _{GS(th)}	V _{DS} =V _{GS} I _D =250 μA	2.0		4.0	V
g _{FS}	V _{DS} =40V I _D =9.0A		13		S
R _{DS(on)}	V _{GS} =10V I _D =9.0A		0.155	0.18	Ω
V _{SD}	V _{GS} =0V I _S =18A			1.5	V
C _{iss}	V _{DS} =25V V _{GS} =0V f=1.0MHz		1130	1470	pF
C _{oss}			225	290	
C _{rss}			80	105	
t _{d(on)}	V _{DD} =100V I _D =18A R _G =25 Ω		21	55	ns
t _r			180	370	
t _{d(off)}			110	230	
t _f			100	210	

IRFS640 (CS640F)

