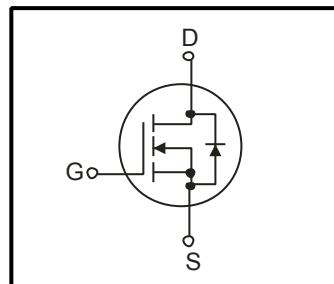
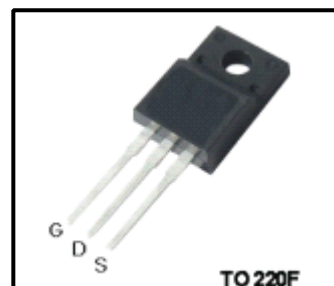

**650V Super-Junction Power MOSFET**
**Features**

- Ultra low  $R_{dson}$
- Ultra low gate charge (typ.  $Q_g = 19nC$ )
- 100% UIS tested
- RoHS compliant

**General Description**

Power MOSFET is fabricated using advanced super junction technology. The resulting device has extremely low on resistance, making it especially suitable for applications which require superior power density and outstanding efficiency.

**Absolute Maximum Ratings**

Symbol	Parameter	Value	Units
$V_{DSS}$	Drain Source Voltage	650	V
$I_D$	Continuous Drain Current ( $T_c=25^\circ C$ ) ( $T_c=100^\circ C$ )	7	A
		4.4	
$I_{DM}$	Drain Current Pulsed <sup>1)</sup>	21	A
$V_{GS}$	Gate to Source Voltage	$\pm 30$	V
$E_{AS}$	Single Pulse Avalanche Energy <sup>2)</sup>	230	mJ
$I_{AR}$	Single Pulse Avalanche Current <sup>1)</sup>	7	A
$E_{AR}$	Repetitive Avalanche Energy <sup>1)</sup>	0.5	mJ
$P_D$	Total Power Dissipation (@ $T_c=25^\circ C$ ) -Derate above $25^\circ C$	31	W
		0.25	W/ $^\circ C$
$T_J$	Junction Temperature	150	$^\circ C$
$T_{stg}$	Storage Temperature	-55~150	$^\circ C$
$I_S$	Continuous diode forward current	7	A
$I_{S,pulse}$	Diode pulse current	21	A

Notes:

1.Repetitive Rating:Pulse width limited by maximum Junction Temperature

2. $I_{AS}=2.5, V_{DD}=60V, R_G=25\Omega, Starting T_J=25^\circ C$

**Thermal Characteristics**

Symbol	Parameter	Value			Units
		Min	Typ	Max	
$R_{\theta JC}$	Thermal Resistance , Junction -to -Case	-	-	4	$^\circ C/W$
$R_{\theta JA}$	Thermal Resistance , Junction -to -Ambient	-	-	80	$^\circ C/W$

## Electrical Characteristics(Tc=25°C unless otherwise noted)

Characteristics	Symbol	Test Condition	Min	Type	Max	Unit
Gate leakage current	$I_{GSS}$	$V_{GS}=\pm 30V, V_{DS}=0V$	-	-	$\pm 100$	nA
Drain cut -off current	$I_{DSS}$	$V_{DS}=650, V_{GS}=0V,$	-	-	1	$\mu A$
		$T_J=25^{\circ}C$	-	10	-	
		$T_J=125^{\circ}C$	-	-	-	
Drain -source breakdown voltage	$V_{(BR)DSS}$	$I_D=250\mu A, V_{GS}=0V$	650	-	-	V
Gate threshold voltage	$V_{GS(th)}$	$V_{DS}=V_{GS}, I_D=250\mu A$	2.5	3.5	4.5	V
Drain -source ON resistance	$R_{DS(ON)}$	$V_{GS}=10V, I_D=3.5A$	-	0.51	0.57	$\Omega$
		$T_J=25^{\circ}C$	-	-	-	
		$T_J=150^{\circ}C$	-	1.2	-	
Gate resistance	$R_G$	$f=1MHz, \text{open drain}$	-	0.4	-	$\Omega$
Input capacitance	$C_{iss}$	$V_{DS}=25V,$	-	710		pF
Reverse transfer capacitance	$C_{rss}$	$V_{GS}=0V,$	-	6		
Output capacitance	$C_{oss}$	$f=1MHz$	-	470		
Turn-on delay time	$t_{d(on)}$	$V_{DD} = 300V, I_D = 3.5A$ $R_G = 12\Omega, V_{GS}=10V$	-	25	-	ns
Rise time	$t_r$		-	10	-	
Turn-off delay time	$t_{d(off)}$		-	54	-	
Fall time	$t_f$		-	65	-	
Gate to source charge	$Q_{gs}$	$V_{DD}=480V, I_D=3.5A,$ $V_{GS}=0 \text{ to } 10V$	-	4	-	nC
Gate to drain charge	$Q_{gd}$		-	9	-	
Gate charge total	$Q_g$		-	19	-	
Gate plateau voltage	$V_{plateau}$		-	5.8	-	

## Source-Drain Ratings and Characteristics(Ta=25°C)

Characteristics	Symbol	Test Condition	Min	Type	Max	Unit
Diode forward voltage	$V_{SD}$	$V_{GS}=0V, I_F=3.5A$	-	-	1.2	V
Reverse recovery time	$t_{rr}$	$V_R=50V, I_F=7A,$ $dI_F/dt=100A/\mu s$	-	290	-	ns
Reverse recovery charge	$Q_{rr}$		-	3.4	-	$\mu c$
Peak reverse recovery current	$I_{rrm}$		-	14	-	A

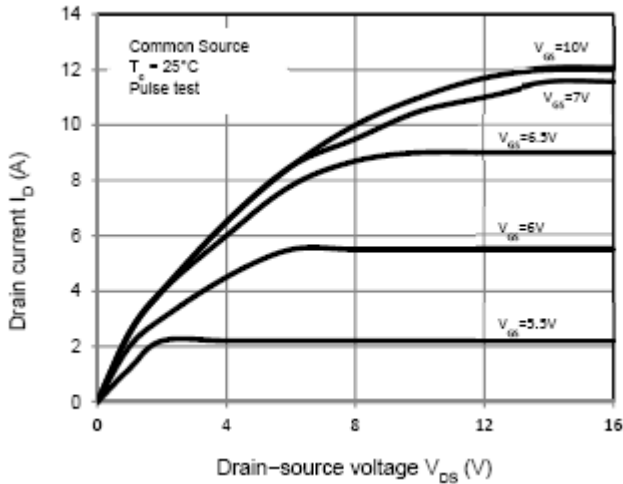

**Fig.1 On-Region Characteristics**

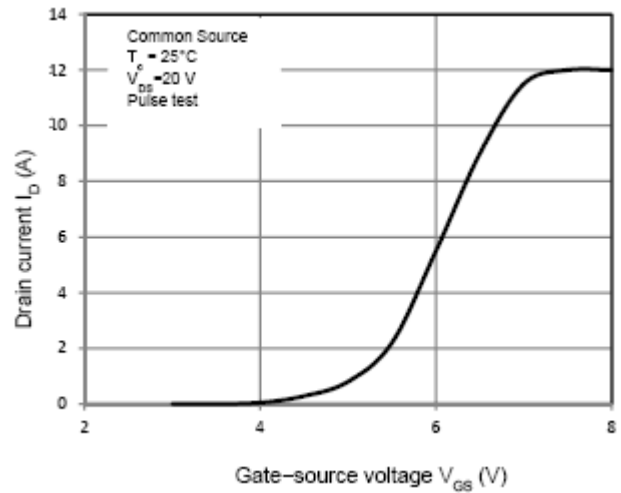

**Fig.2 Transfer Characteristics**

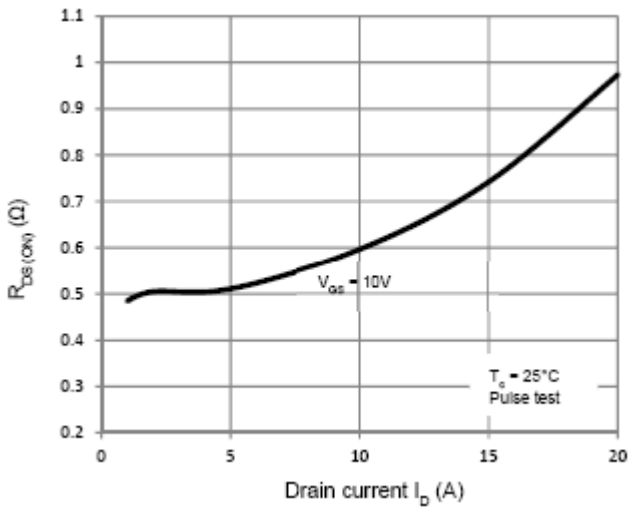

**Fig.3 On-Resistance Variation vs. Drain Current**

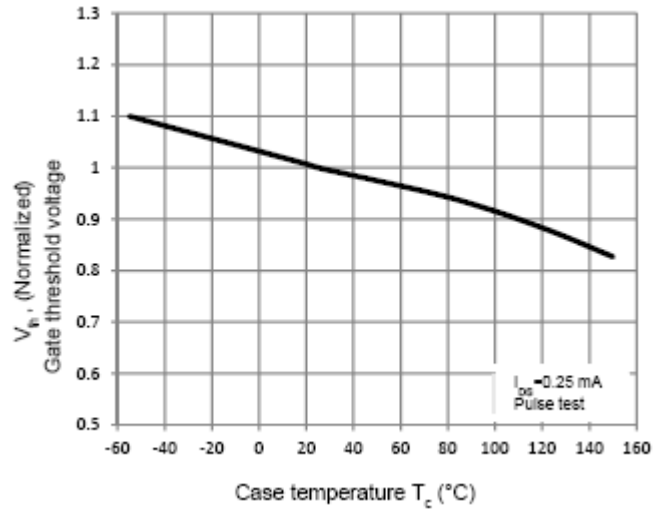

**Fig.4 Threshold Voltage vs. Temperature**

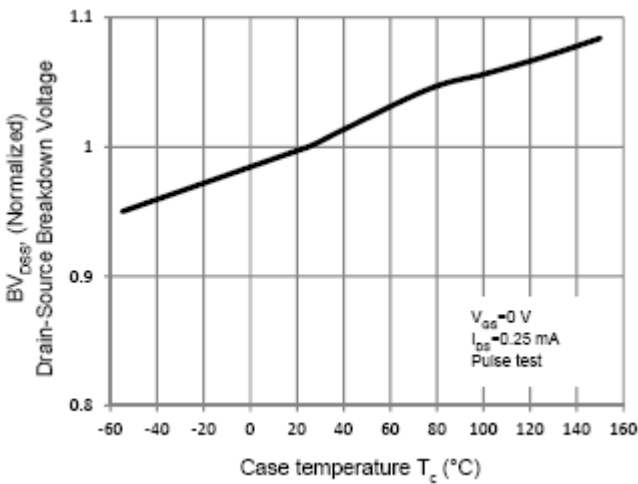

**Fig.5 Breakdown Voltage vs. Temperature**

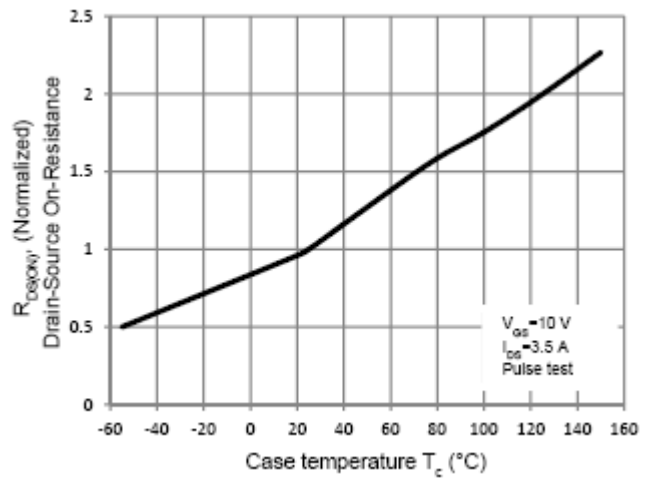

**Fig.6 On-Resistance vs. Temperature**

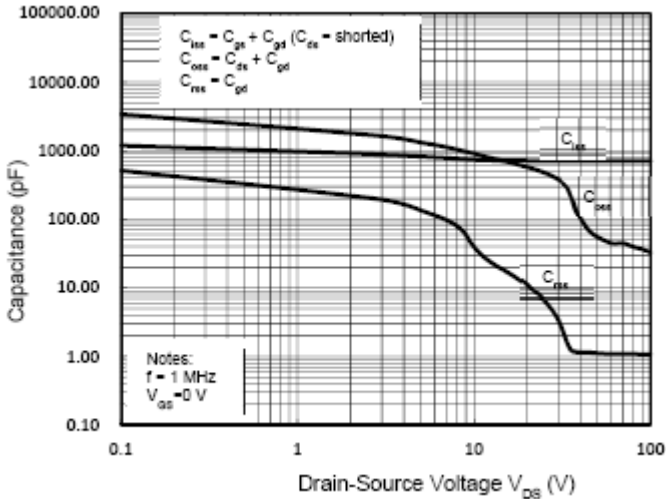

**Fig.7 Capacitance Characteristics**

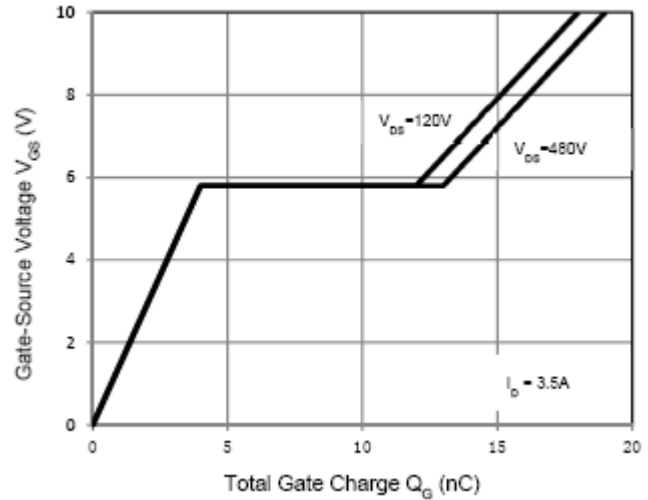

**Fig.8 Gate Charge Characteristics**

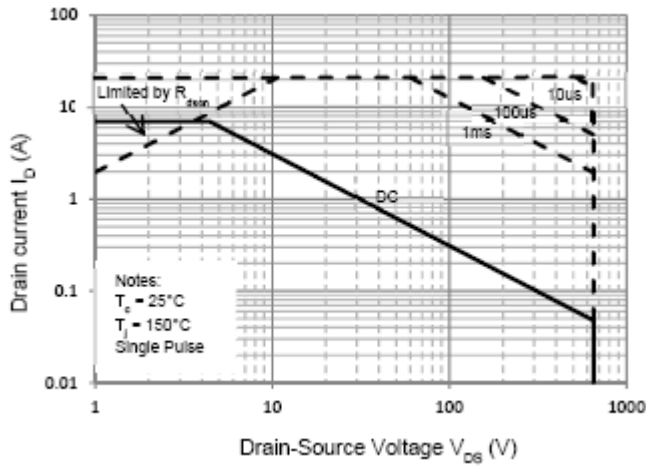

**Fig.9 Maximum Safe Operating Area**

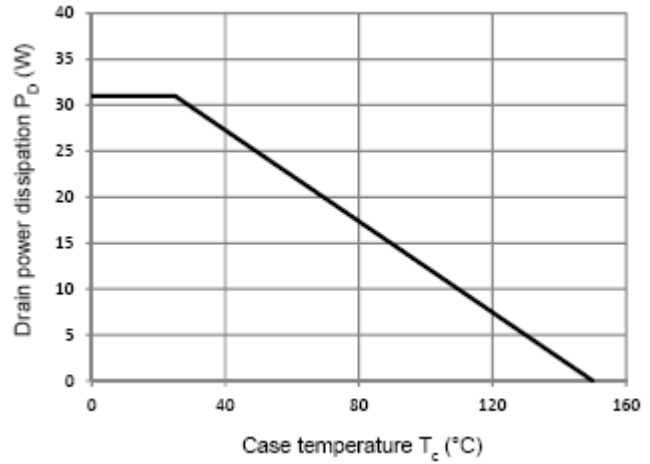

**Fig.10 Power Dissipation vs. Temperature**

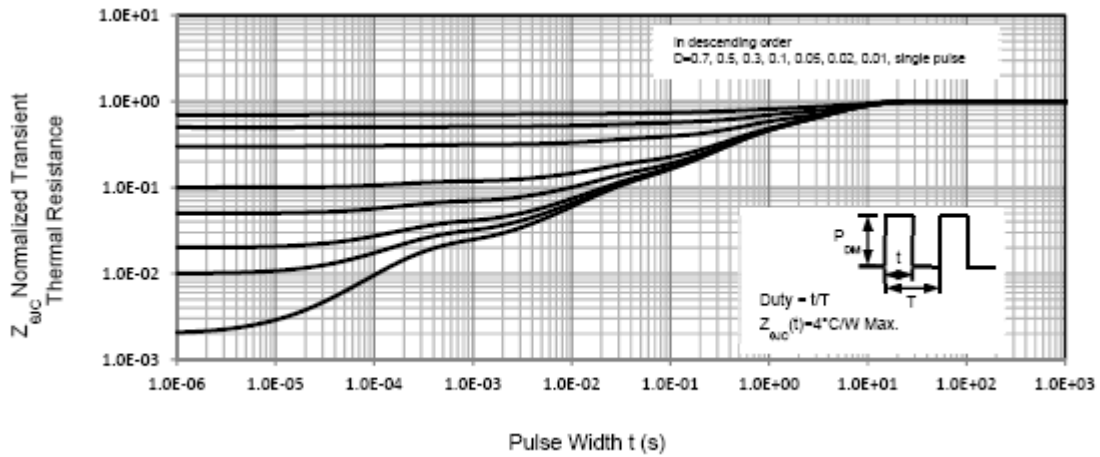

**Fig.11 Transient Thermal Response Curve**

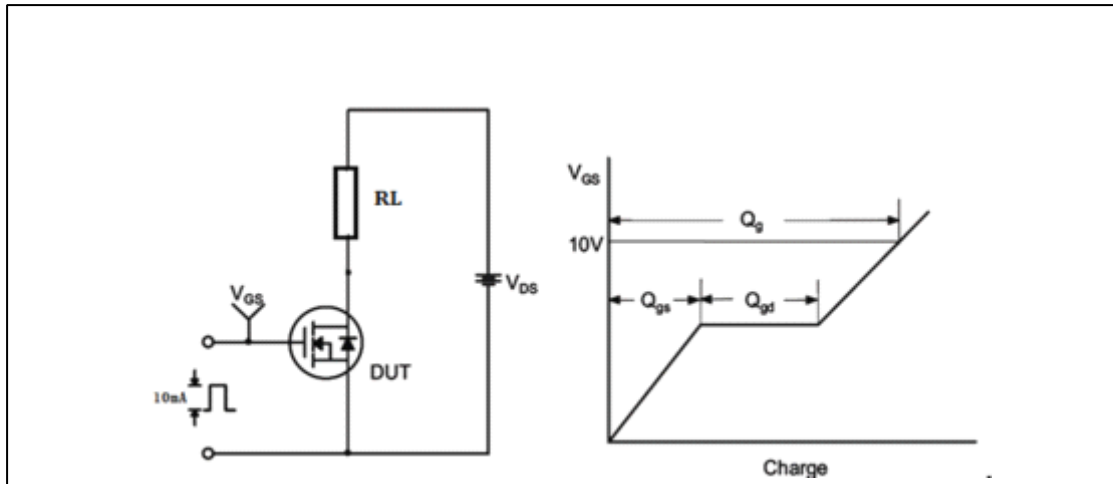

**Fig.12 Gate Charge Test Circuit & Waveform**

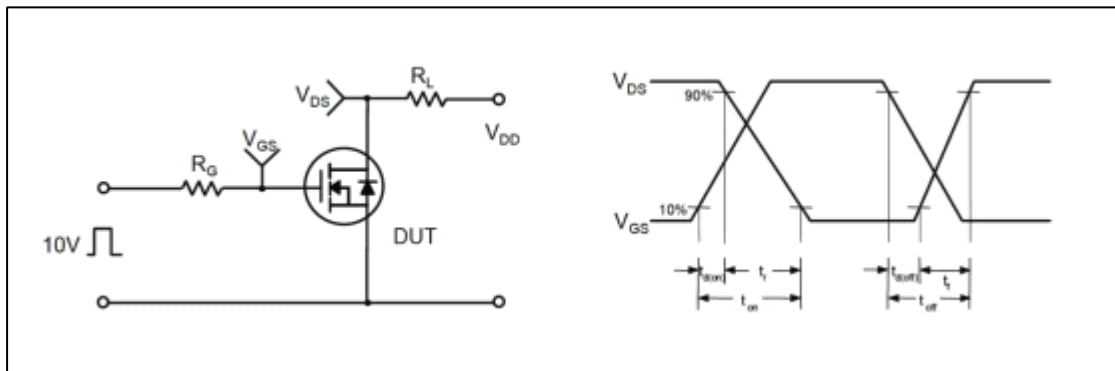

**Fig.13 Switching Test Circuit & Waveforms**

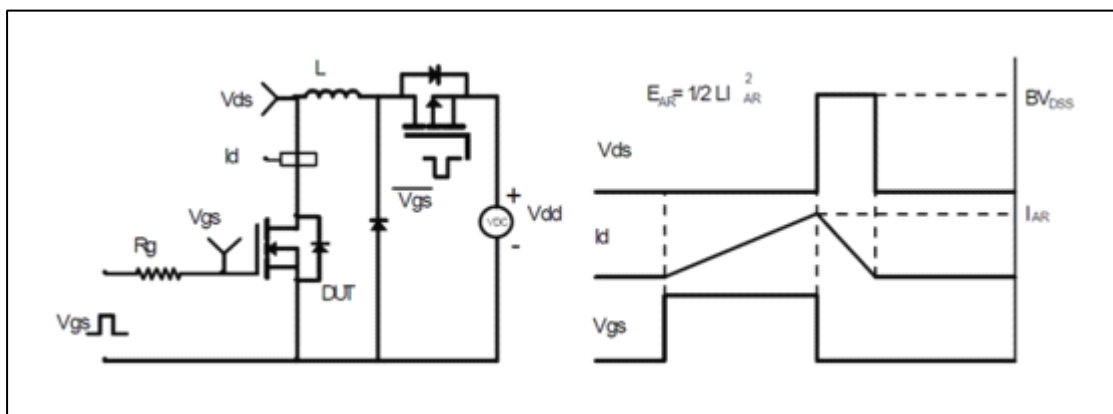

**Fig.14 Unclamped Inductive Switching Test Circuit & Waveform**

**TO-220F Package Dimension**

