

Silicon N-Channel MOSFET

Features

- Ultra low $R_{ds(on)}$
- Ultra-low Gate charge(Typical 68nC)
- 100% UIS Tested
- RoHS compliant

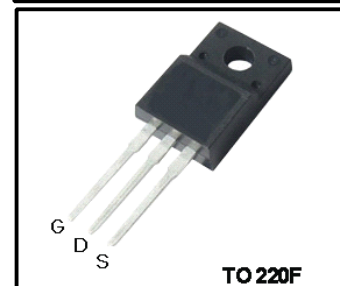
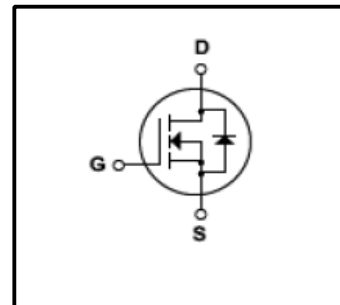

General Description

Winsemi Power MOSFET is fabricated using advanced super junction technology. The resulting device has extremely low on resistance, making it especially suitable for applications which require superior power density and outstanding efficiency.

Absolute Maximum Ratings

Symbol	Parameter	Value	Units
V_{DSS}	Drain Source Voltage	600	V
I_D	Continuous Drain Current(@ $T_c=25^{\circ}C$) (@ $T_c=100^{\circ}C$)	20	A
		13	A
I_{DM}	Drain Current Pulsed ¹⁾	60	A
V_{GS}	Gate to Source Voltage	± 30	V
E_{AS}	Single Pulse Avalanche Energy ²⁾	700	mJ
I_{AR}	Single Pulse Avalanche Current ¹⁾	20	A
E_{AR}	Repetitive Avalanche Energy ¹⁾	20.5	mJ
P_D	Total Power Dissipation(@ $T_c=25^{\circ}C$) -Derate above $25^{\circ}C$	34	W
		0.28	W/ $^{\circ}C$
T_J	Junction Temperature	150	$^{\circ}C$
T_{stg}	Storage Temperature	-55~150	$^{\circ}C$
I_S	Continuous diode forward current	20	A
$I_{S,pulse}$	Diode pulse current	60	A

Thermal Characteristics

Symbol	Parameter	Value			Units
		Min	Typ	Max	
R_{QJC}	Thermal Resistance , Junction -to -Case	-	-	3.6	$^{\circ}C/W$
R_{QJA}	Thermal Resistance , Junction -to -Ambient	-	-	80	$^{\circ}C/W$

Electrical Characteristics(Tc=25°C)

Characteristics	Symbol	Test Condition	Min	Type	Max	Unit
Gate leakage current	I _{GSS}	V _{GS} =±30V, V _{DS} =0V	-	-	±100	nA
Drain cut -off current	I _{DSS}	V _{DS} =600V, V _{GS} =0V	-	-	1	μA
Drain -source breakdown voltage	V _{(BR)DSS}	I _D =250μA, V _{GS} =0V	600	-	-	V
Gate threshold voltage	V _{GS(th)}	V _{DS} =V _{GS} , I _D =250uA	2.5	-	4.5	V
Drain -source ON resistance	R _{DS(ON)}	V _{GS} =10V, I _D =10A T _J =25°C T _J =150°C	-	0.13	0.15	Ω
			-	0.39	-	
Gate resistance	R _G	F=1MHz, open drain	-	1.8	-	Ω
Input capacitance	C _{iss}	V _{DS} =25V, V _{GS} =0V, f=1MHz	-	2100		pF
Reverse transfer capacitance	C _{rss}		-	17		
Output capacitance	C _{oss}		-	1700		
Total gate charge(gate-source plus gate-drain)	Q _g	V _{DS} =480V, V _{GS} =0 to 10V, I _D =20A	-	68	-	nC
Gate-source charge	Q _{gs}		-	27	-	
Gate-drain("miller") Charge	Q _{gd}		-	20	-	
Gate plateau voltage	V _{plateau}		-	6.2	-	

Source-Drain Ratings and Characteristics(Ta=25°C)

Characteristics	Symbol	Test Condition	Min	Type	Max	Unit
Body Diode Voltage	V _{SD}	I _{SD} =10A, V _{GS} =0V	-	-	1.4	V
Pulse Diode Forward Current	I _{tr}	V _R =50V, I _F =20A, dI _F /dt= 100A/μs	-	520	-	
Reverse recovery time	Q _{rr}		-	5.7	-	
Peak reverse recovery current	I _{rrm}		-	19	-	

Notes:

- 1.Repetitive Rating:Pulse width limited by maximum junction temperature
- 2.I_{AS}=7A, V_{DD}=60V, R_G=25Ω, Starting T_J=25°C

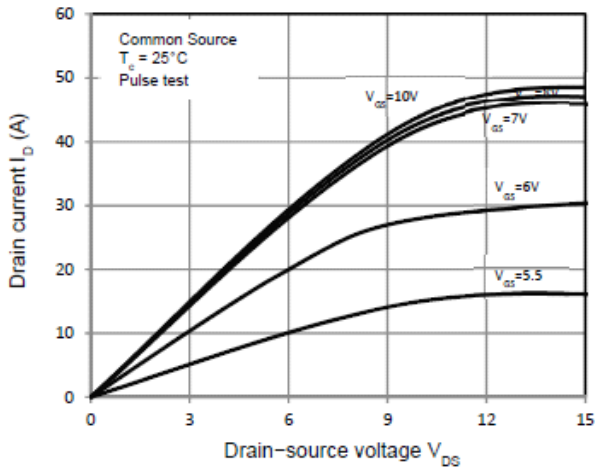

Fig.1 On-Region Characteristics

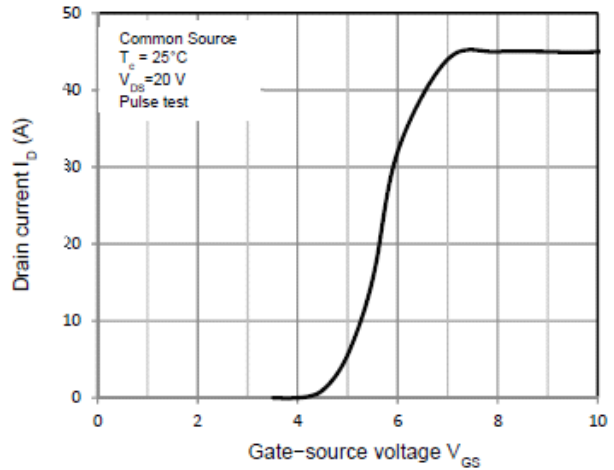

Fig.2 Transfer Characteristics

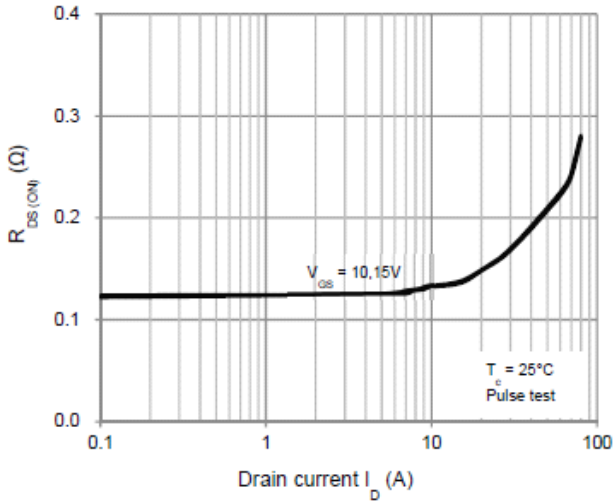

Fig.3 On-Resistance Variation vs Drain Current

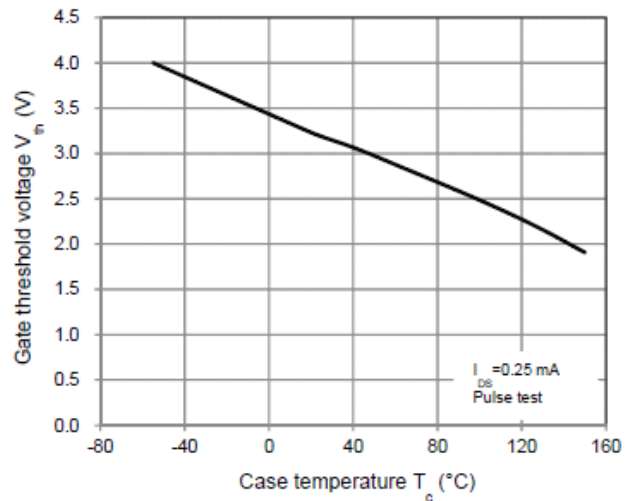

Fig.4 Threshold Voltage vs. Temperature

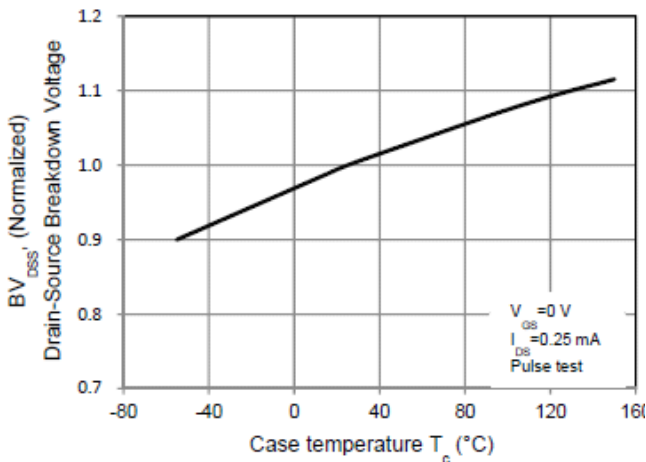

Fig.5 Breakdown Voltage vs. Temperature

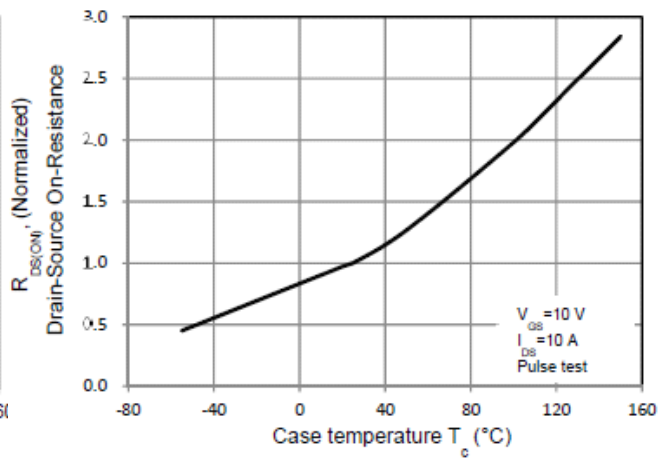

Fig.6 On-Resistance vs. Temperature

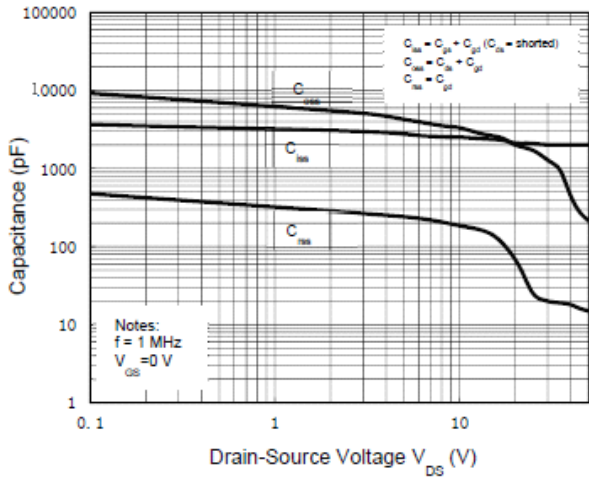

Fig.7 Capacitance Characteristics

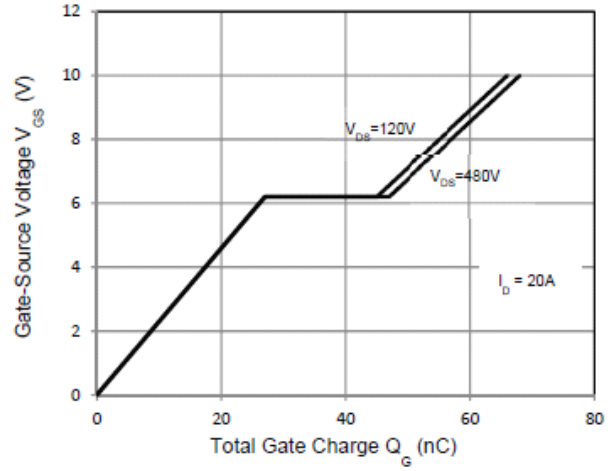

Fig.8 Gate Charge Characteristics

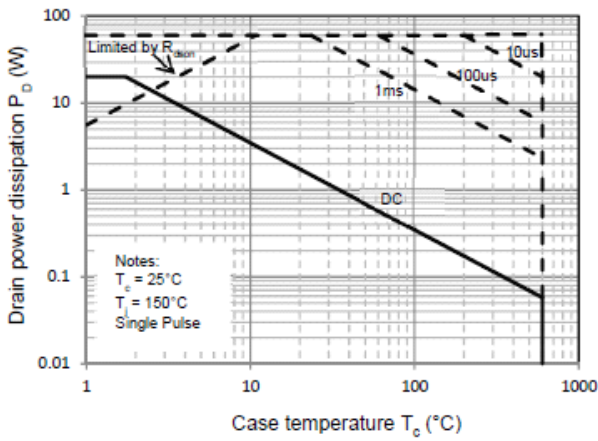

Fig.9 Maximum Safe Operating Area

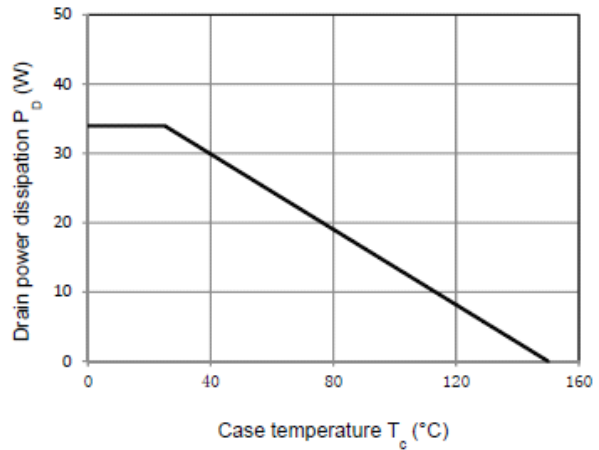

Fig.10 Power Dissipation vs. Temperature

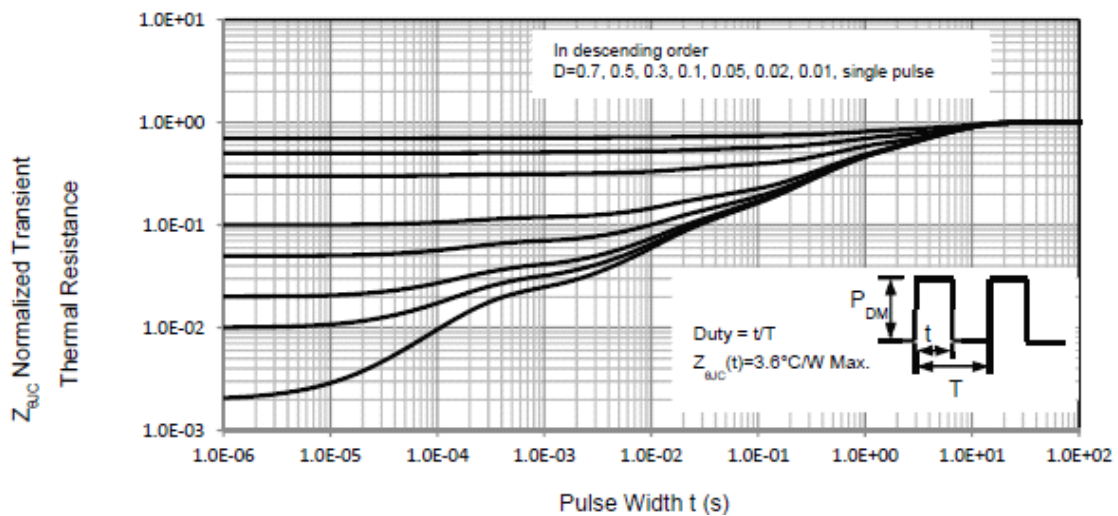

Fig.11 Transient Thermal Response Curve

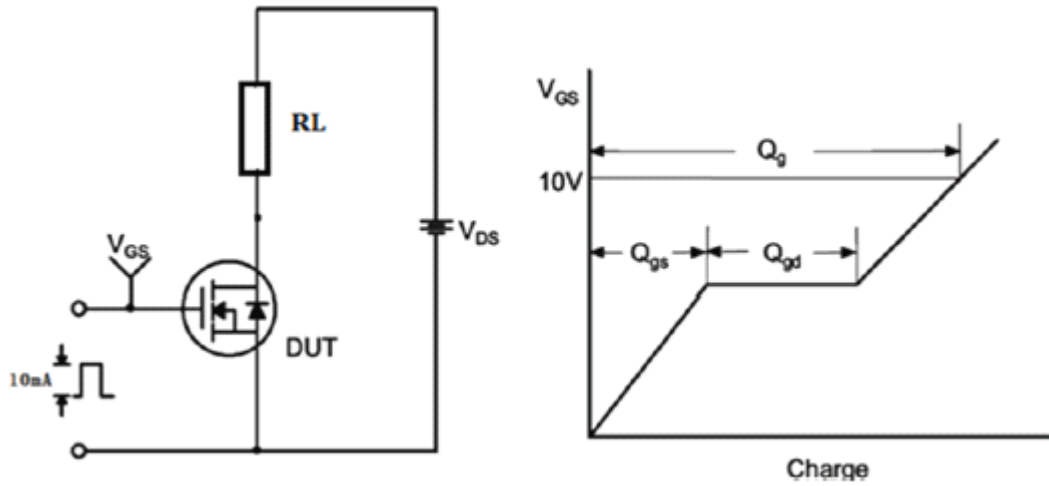

Fig.11 Gate Charge Test Circuit & Waveform

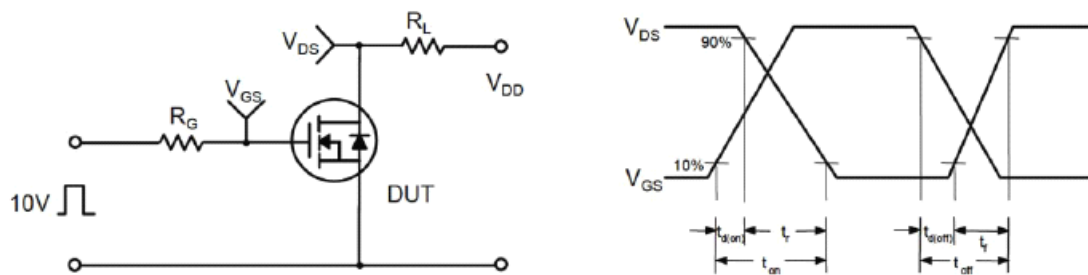

Fig.12 Switching Test Circuit & Waveforms

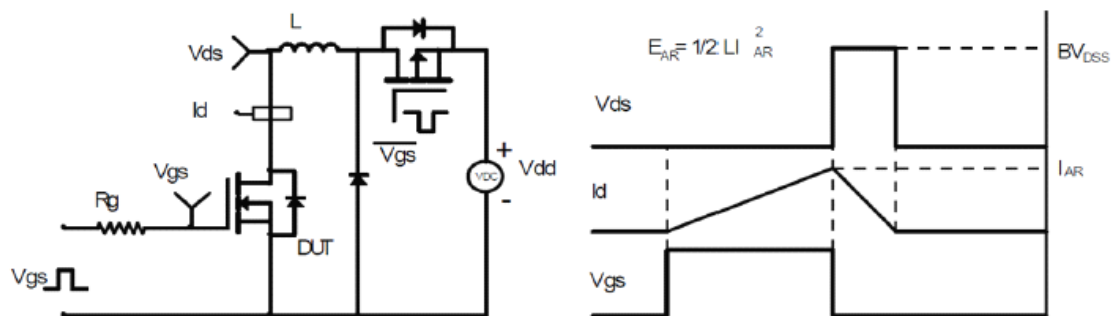

Fig.13 Unclamped Inductive Switching Test Circuit & Waveforms

TO-220F Package Dimension

